

Zeitschrift: IABSE congress report = Rapport du congrès AIPC = IVBH
Kongressbericht

Band: 14 (1992)

Rubrik: Plenary Session 2: Structural contribution to natural disaster reduction

Nutzungsbedingungen

Die ETH-Bibliothek ist die Anbieterin der digitalisierten Zeitschriften. Sie besitzt keine Urheberrechte an den Zeitschriften und ist nicht verantwortlich für deren Inhalte. Die Rechte liegen in der Regel bei den Herausgebern beziehungsweise den externen Rechteinhabern. [Siehe Rechtliche Hinweise.](#)

Conditions d'utilisation

L'ETH Library est le fournisseur des revues numérisées. Elle ne détient aucun droit d'auteur sur les revues et n'est pas responsable de leur contenu. En règle générale, les droits sont détenus par les éditeurs ou les détenteurs de droits externes. [Voir Informations légales.](#)

Terms of use

The ETH Library is the provider of the digitised journals. It does not own any copyrights to the journals and is not responsible for their content. The rights usually lie with the publishers or the external rights holders. [See Legal notice.](#)

Download PDF: 07.10.2024

ETH-Bibliothek Zürich, E-Periodica, <https://www.e-periodica.ch>



Plenary Session 2

Structural Contribution to Natural Disaster Reduction

Contribution du génie civil à la réduction des catastrophes naturelles

Beitrag des Bauwesens zur Verminderung von Naturkatastrophen

Organizer: Johan Blaauwendraad,
The Netherlands

Leere Seite
Blank page
Page vide



Structural Contribution to Natural Disaster Reduction

Contribution du génie civil à la réduction des catastrophes naturelles

Bauliche Vorkehrungen gegen Naturkatastrophen

D. K. SINHA

Prof. of Applied Math.
Univ. of Calcutta
Calcutta, India

SUMMARY

The central message of the International Decade of Natural Disaster Reduction (IDNDR) is that in any endeavour pertaining to IDNDR, 'pre' elements should have a precedence over 'post' counterparts. This shift in paradigm has obviously implications for developmental activities pertaining to IDNDR. Prevention, Preparedness, Response, Recovery and Rehabilitation form the bulwark of IDNDR, and any developmental effort must necessarily reflect these essential components; also any structural activity that impinges on enterprises peculiar to the profession. Risks and vulnerabilities for every structural enterprise need to be identified and considered in the context of tenets of IDNDR. Accordingly, risk assessment on the basis of prior knowledge of mapping of disaster prone areas becomes a must for any constructional activity.

RÉSUMÉ

Le message essentiel de la "Décade internationale pour la réduction des catastrophes naturelles" (IDNDR) est qu'il faut donner la priorité aux mesures de protection avant toute catastrophe potentielle plutôt qu'à des aides postérieures. Ce changement de priorités a naturellement des conséquences pour les activités dans le programme IDNDR; ces dernières peuvent être caractérisées par les cinq termes: prévention, préparation, réaction, rétablissement et reconstruction. Toutes les actions entreprises dans le cadre IDNDR, y compris celles en relation avec le génie civil, doivent nécessairement refléter ces éléments. Les dangers et les faiblesses doivent être évalués selon les principes IDNDR. Quelques exemples illustrent les caractéristiques de quelques constructions vis-à-vis d'effets de certaines catastrophes.

ZUSAMMENFASSUNG

Zentrales Anliegen der Internationalen Dekade zur Verringerung von Naturgefahren (IDNDR) ist in allen Bereichen der Vorrang von Vorsorgemaßnahmen gegenüber der Hilfe nach Eintritt der Katastrophe. Der Paradigmenwechsel wurde in die fünf Schlagworte Verhütung, Bereitschaft, Reaktion, Erholung und Wiederherstellung gefasst. Diese Komponenten erscheinen notwendigerweise in allen Entwicklungsanstrengungen und zugehörigen Bauaktivitäten: Risiken und Verwundbarkeit aller Bauprojekte müssen identifiziert und an den IDNDR-Prinzipien gemessen werden. Generelle Ausführungen zu diesen Prinzipien werden anhand der Eigenschaften einiger Bauwerke gegenüber ausgewählten Katastropheneinwirkungen erläutert.



1. INTRODUCTION

It would sound like a travesty of history and truth, as well if there is an assertion that there has not been hitherto any endeavour to contain, to preempt and to grapple with natural disasters. Noah's heroic effort for mitigating a natural disaster is a classic example of its kind. The contemporary surge of interest and activity on natural disasters can largely be attributed to developments in Science & Technology (S & T) and the use of the same in such contexts. IDNDR not only conjures up what have gone by but also opens up what need to be generated in the arena of S & T. All facets of Science, Engineering and Technology need to be looked at afresh and Structural Engineering (SE), in particular, can hardly escape from such exercises. This paper is essentially an attempt to harp on IDNDR so that SE can acquire new dimensions. Hence considerations of perspectives of IDNDR are to be necessarily resorted to, vide, Sinha [1, 2, 3, 4, 5, 6, 7] and this is precisely what follows this introduction. Having sought these, it is found worthwhile to identify and also to seek overall features pertaining to SE. Some specific natural disasters are then touched upon briefly so as to facilitate further discussions on building codes, building practices etc. Finally some remarks are set forth so that imperatives of IDNDR are met not just as rituals but as far reaching activities with inputs from traditionally deemed extra-engineering sectors on a continuing basis.

2. IDNDR : A CRITIQUE

The UN resolution on IDNDR, effectively put into operation nearly two years ago, proves, doubtless, the genesis of the concept of IDNDR; the concept has since then evolved on account of versions in a variety of national contexts and of commentaries, as well. Such exercises keep on adding lustre and rich complexions to the concept per se. Indeed, perspectives of IDNDR continue to be built around three major subconcepts : (a) the generation of knowledge about natural disasters (b) the dissemination of the knowledge (c) the application of knowledge. Apparently, this sequence may run counter to a ritualistic way of setting forth the goals of IDNDR but the essence of the concept as a whole is hardly diluted. Speaking in relatively mundane terms, to improve the capacity to mitigate the impact of natural disasters, to draw upon the extent knowledge, to disseminate information across potential users to foster scientific and technological research so as to build up predictive capability, to prepare, to educate and to make the country aware about natural disasters continue to be overriding tenets of IDNDR. The accent of IDNDR is more on 'pre'part rather than 'post' counterpart which, in a way, has continued somewhat unabated in an uncritical manner. IDNDR is a pointer to take up cudgels so as to grapple with natural disasters as an ongoing endeavour, reckoning scenarios and milieu. The comprehensive character of UN resolution on IDNDR hardly leaves anything for thoughts and activities on natural disasters to any adhocism and laissezfaire effort; on the contrary, any component of it whatever be the phase pre/post/during - disaster, can hardly develop if it is delinked from the overall conceptual construct of IDNDR. As a corollary, it follows that any functionary working in this field has to be imbued with the central message of IDNDR so that one may distill the essence of it in the field of SE.



3. IDENTIFICATION OF RELEVANT FACETS

Of all aspects of activities in the wake of IDNDR, natural disaster preparedness and mitigation continue to play dominant roles while recovery and redevelopment take place after the occurrence of such phenomena. It has almost become banal to say that building practices need to be stressed as effective approaches for minimizing the effects of natural disasters. A natural disaster has little or no impact when a structure is rationally designed, appropriately constructed and adequately maintained so as to withstand the onslaught of disasters. This brings in its trail a variety of issues and problems for the simple reason that the first part of it namely the design is, by all counts, in such contexts, complicated problem. From the standpoint of structural mechanics one may pose the questions: what forces will the structure be subjected to? How do they interact? How do construction materials respond to the forces of onslaught? IDNDR calls upon every engineer and more so, a structural engineer to answer such questions.

Let us delve a bit into this. First let us talk about building practices. There is hardly any dearth of practices on this score. By and large, these are empirical in nature and over the years, prior to the beginning of IDNDR engineers have generally drawn upon these rules so as to make buildings perform well during natural disasters. On the other hand, new building practices throughout the world galore, one must cull those elements that are highly innovative; even if these are fraught with new limitations, they offer opportunities to think about and to do something later on. Construction techniques have improved considerably over the decades. It is often held that cement mortar rather than lime mortar, using reinforcing steel on attaching diaphragms to the walls may be used so that vulnerability of masonry buildings in the wake of natural disasters can be greatly lessened; in fact, in the case of earthquakes, the damage can be minimized. Likewise, if the roof is attached to the walls and walls to the foundation of a wooden framehouse. destruction because of severe winds, cyclones etc. may not be that enormous. Closely on the heels of safe construction are techniques and criteria that otherwise go by the labels 'building codes and regulations'.

4. SOME SPECIFICS

It would be helpful if we begin with an example. India like many others is a country that has to concentrate attention to construction of houses, shelters etc. which need to withstand somehow the ravages of cyclone, because of fairly large areas prone to cyclones and floods. Housing is also found in jeopardy because of landslides in hilly regions; the same is true of areas prone to seismic tendencies. Hence, from a wider standpoint housing and vulnerability are inextricably bound up. Badly sited houses for example buildings on flood plains, badly constructed houses, bad roof constructions etc. give rise to vulnerability in various forms. Indeed this is what led O'Keefe [8] to set forth the precise definition of natural disasters as interfaces between a natural disaster and a vulnerable condition such as those mentioned just now. Davis [9] 's seminal work brings to the fore not only the issues but also strategies for survival, safety measures for building practices etc. One must readily mention recommendations of Cyclone Review Committee chaired by late Prof. A. K. Saha [10] this report has a definite relevance to other countries as well, even though intended for the Indian setting.



In regard to floods, a near annual affair in our setting, 'flood proofing' has a bearing on SE practices. Here the need is to design or even to reconstruct buildings so as to reduce the potential flood damage; one of the activities is to raise buildings on silts or bunds or to construct water tight walls and gates properly. Flood plain management is a crucial procedure in developing countries like Bangladesh; in fact, indigeneous ways of such a management requires a novel and fresh approach to building and construction practices.

Such problems warrant ~~from~~ a wider point of view namely wind disaster mitigation vis-a-vis building structures. The continuing concern here is about damage caused by winds associated with natural disasters; indeed, as is well known, wind storms occur with wind speeds in excess of design speeds which therefore bring about damage. It may just be mentioned that the Institute for Disaster Research, Texas Technological University, USA has done an excellent job on documentation of damage in a large number of wind storm incidences, according to which one can categorize diverse nature of buildings. There is a host of problems indentified from the standpoint of building structures but these are left out here in the hope that they are covered elsewhere as key facets.

A few remarks about effects of earthquakes on structures. There is a tendency in such situations to look for an optimality of loss vis-a-vis costs incurred. But this can in no way be the rationale for prioritizing the task of formulating and enforcing building codes. Any kind of decision on optimality regarding earthquake risks must go in for predictions (probabilistic) of what are customarily called 'ground motions' and certainly their adverse effects on structures, people, property etc. Hence, having undertaken indepth research on better assesment of probabilistic parameters of earthquake magnitudes, location of potential sources and times of occurence, one should look for zoning and micro zoning. These bring up a host of problems, the most important of which is whether one can allow constructions in vulnerable areas. What is often overlooked is that design coefficients of different types of structures should not be proportional from zone to zone and also that these coefficients depend on how sensitive a structure is to ground motion-duration which increases with focal distances. Structural responses, structural capacity etc. are topics that need totally new consideration during IDNDR. Obviously, as mentioned above there is a tremendous scope for mathematical modelling on this score besides the task of quantifying risks and associated sensitivity studies.

BUILDING CODES & PRACTICES

It is well known that the basic parameters to codify wind effects are wind speed, terrain exposure, building geometry, building permeability etc. These lead to model building codes which, it is presumed, will be dealt with in depth in the other plenary lecture. But it would not be inappropriate to refer to standard codes in different national setting, for example the Indian Standard (IS) code. It has several plus points particularly on mapping giving zones of different wind processes varying with height; ofcourse from a certain height above the ground level. It is not clear whether such codes put any stipulation on the design of low rise buildings vis-a-vis velocity and time of winds. There is thus a large area for research particularly the study of variation of wind height and other characteristics of cyclonic winds so essential for codal specifications. It is often recomended that cyclone-resistant houses with



precast reinforced concrete skeleton with roof and infilled walls made for housing in cyclone prone areas. As desired in the goals of IDNDR, we ought to implement compatible recommendations, particularly on codes and design vis-a-vis damage analysis, of Indo-US workshop [11] on the theme.

The contemporary experience on building and construction practices shows that remarkable and vast changes have come up in this direction. Some of them are being grafted on elsewhere without reckoning deeper implications. What is often glossed over is the validation of new methods both from observational and laboratory points of view. The tendency seems to be for new buildings and far from rehabilitating existing unsafe buildings which recent R & D efforts may bear out. We have to turn necessarily once again to the tenets of IDNDR which should compel us to undertake what is often called problem - focussed applied research, vide Housner [12]; the safety analysis of existing concrete dams against earthquakes or construction of new ones is an example in point. No single country, it looks, can afford to contain seismically vulnerable styles of ground on its own, primarily because of lack of adequate instrumentation and hence lack of recording an information, too. It is being increasingly felt that each country in the context of IDNDR, ought to take up, notwithstanding disaster preparedness, pilot projects on (a) reducing the vulnerability of residential housing (b) developing repair procedures and (c) consistent building regulation standards and practices.

CONCLUDING REMARKS

The reconnaissance report on the last Armenian earthquake has brought to the fore, besides harrowing tales of horror and sorrow, serious lacunae on construction codes and standards in Armenian Soviet Socialist Republic. Research and data acquisition (and surely prediction) continue to mitigate natural disasters only to the extent that they are integral parts of a mitigation process which should include (a) the design and the construction of disaster resistant structures and other facilities (b) the strengthening or dismantling vulnerable existing structures and (c) land management that eliminates or modifies the construction of structures on hazardous sites. As already remarked, a lot of scientific and technological activity should become necessary for every attempt to mitigate natural disasters. Tinkering or refurbishing the interior many times in any building has to be abjured.

A structural engineer has to keep in view the totality of sequence of measures on disaster mitigation. This may be structured in the way the tenets of IDNDR are set forth. First, one has to have a building inventory which alone can provide the essential database for the building loss estimate, whatever be the site; second, estimates about damage and loss; third, adoption and adaptation of building codes and measures; fourth, design and development of building practices including constructional practices. An important ancillary, if not a back up activity, is expansion of educational efforts directed towards all segments of building community. What is often lost sight of is that natural disaster mitigation process must be applied to relevant life lines that are usually categorized as (a) water and sewer facilities (b) transportation facilities (c) communication facilities (d) electric power facilities and (e) gas and liquid fuel lines.



Model scenarios on natural disasters, as advocated in the UN report of the Adhoc Expert Committee on IDNDR, have relevance hereto. This is all the more necessary for a local engineer who has to understand broader community processes set in train by natural disasters. The Counter Disaster College of Australia [13] has dwelt on models of disasters for such categories of functionalities. Such exercises on modelling and simulation shed insights into occurrence of events which are yet to be; of course model studies perse, at a deeper level, for example, on stochastic models, on wind climate, of wind speed and of wind structure are afoot. The measure of uncertainty is a vexed issue; one has often to turn to reliability theory for assessing properly uncertainties. Risk assessment has a definite theoretical content in the context of natural disasters.

In sum, one can perhaps say that IDNDR calls upon us to examine threadbare the understanding of the relation between natural disasters and housing without losing the total framework. The Disaster Management Centre at Oxford has done some exemplary work on small dwelling, safer settlements and low income dwellings which can scarcely dispense with few cross cutting issues such as risk assessment, emergency planning, risk mitigation, training and education. All these speak obviously of an integrated approach. Frontier ideas, thoughts and as a spin off, appropriate technology in this context have become essential. But that NGO's, governments, academia and funding agencies need to share roles and responsibilities can hardly be contested now; insurance that has taken so far a backseat in many developing countries has to come up now. So is the case with private sector which can hardly ill afford to shirk its responsibility now and more so, when there is a renewal of thinking on economic overtures in developing countries like ours. In brief, a structural engineer has to combine in one self the traits of a management scientist so that physical & financial management aspects are adroitly handled.

As all such programmes and activities are basically concerned with human elements, human touch can hardly be overlooked. Social and cultural milieu, values and ethics can in no way be lost sight of. Community based mitigation [14] has to holdsway, reckoning S & T. A total view is therefore a must and an integrated approach becomes inevitably a part of daily usage. A structural engineer imbued with such values and qualities may aspire to be a disaster activist without shedding professional roles and responsibilities that have become all the more onerous and contingent on the building community because of IDNDR. One can then hope for a structural S&T to keep pace with evolution of concepts and ideas on IDNDR, tempered with professionalism, compassion and dedication.



REFERENCES

1. SINHA, D.K. : Coping with Natural Disasters : An integrated approach, General Presidential Address, 78th Indian Science Congress, 1991.
2. SINHA, D.K. : Natural Disaster Reduction for Nineties : Perspectives, (ED.) Aspects & Strategies, International Journal Services, Calcutta (In press).
3. SINHA, D.K. : Readings on Natural Disaster Reduction, (1990), (ED.) Monograph, Centre for Atmospheric Sciences, University of Calcutta.
4. SINHA, D.K. : IDNDR : a critique on Information Management, CSI - 90, Silver Jubilee Convention (1990), pp. 47-49.
5. SINHA, D.K. : Some remarks on Management of Natural Disasters pertaining to Coastal Areas in Coastal Zone Management of West Bengal (1991), Sea Explorers' Institute, Calcutta.
6. SINHA, D.K. : Key note Address, Seminar on 'Natural Disasters' Scenario of West Bengal, Indian Science Congress Association, 1991, Calcutta.
7. SINHA, D.K. : Natural Disaster Management : a critique of Trends & Perspectives, Theme lecture, All India meeting of S & T Councils and Departments, (1991), Goa, India.
8. O'KEEFE
PHILLIP : Taking the naturalness out of natural disasters, Nature, Vol. 260 (15 April), 1976, pp. 566.
9. DAVIS, I : Shelter After Disaster, Oxford Polytechnic Press (1978), Oxford
10. SAHA, A.K. : Cyclone Review Committee (1986), Vol. III, Dept. of Science & Technology, Govt. of India, New Delhi.
11. INDO-US
WORKSHOP : Wind Disaster Mitigation (1985), Deptt. of Science & Technology, Govt. of India and National Science Foundation USA.
12. HOUSENER,
G.W. : An International Decade of Natural Disaster Reduction : 1990 - 2000, Natural Hazards (1990) Vol. 2 No. 1 pp. 45-76.
13. ACKEHURST,
ETAL : The Local Government Engineer in Disaster Recovery, Australian Counter Disaster College, 1989.
14. MASKREY,
ANDREW : Disaster Mitigation - A community based approach, Oxfam (1989). Oxford

Leere Seite
Blank page
Page vide

Earthquake Hazard Mitigation in New and Existing Structures

Réduction du danger dans les structures exposées aux séismes

Reduzierte Erdbebengefahr bei neuen und alten Tragwerken

Frieder SEIBLE

Prof. of Struct. Eng.
Univ. of California,
San Diego La Jolla, CA, USA

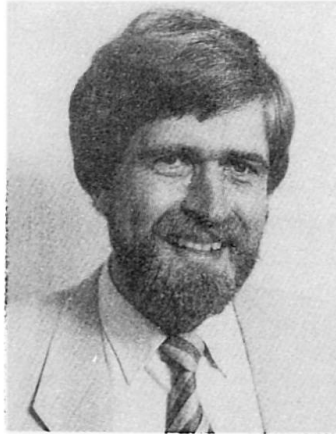

Frieder Seible has been a member of the UCSD faculty for 8 years. He has Civil Engineering Degrees from Germany, Canada and the USA and he is a member of the Seismic Advisory Board for Caltrans. His research interests combine large scale experimental testing and nonlinear analytical modelling of structural concrete systems.

M.J. Nigel PRIESTLEY

Prof. of Struct. Eng.
Univ. of California,
San Diego La Jolla, CA, USA

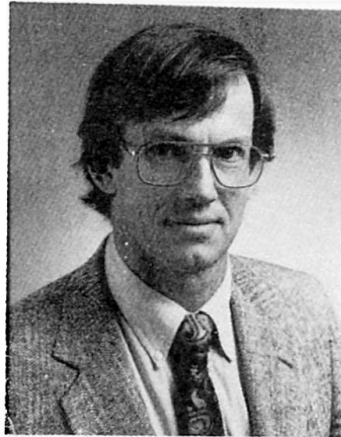

M.J. Nigel Priestley has received numerous international awards (ACI, PCI) for his earthquake engineering and structural concrete and research contributions. He had been a member of the faculty of the University of Canterbury, Christchurch, New Zealand for eleven years prior to joining USCDC.

SUMMARY

The unpredictable and devastating nature of earthquakes and the socio-economic consequences resulting from the failure of man-made structures emphasize the responsibility of the civil engineering profession with every major seismic event. Failures of civil structural systems in past earthquakes have shown that structural earthquake hazards exist around the world independent of the level of technical, cultural, social or economic development, and that earthquake hazard mitigation is a problem which needs to be addressed globally. Fundamental steps towards a rational and comprehensive structural systems design approach for earthquake hazard mitigation are outlined.

RÉSUMÉ

La nature imprévisible et dévastatrice des tremblements de terre et les conséquences socio-économiques résultant de la défaillance de structures anciennes et nouvelles mettent en relief la responsabilité des ingénieurs civils, chaque fois que se produit un séisme. Les ruptures de systèmes structuraux des bâtiments, survenues au cours de tremblements de terre récents et anciens, ont montré que les dangers dus aux séismes et encourus par les structures existent partout dans le monde, indépendamment du niveau de développement technique, culturel, social ou économique. De plus, la réduction du danger des tremblements de terre est un problème qu'il faut aborder globalement. Cet article esquisse les étapes fondamentales à effectuer vers une méthode rationnelle et globale de calcul des systèmes structuraux dans la réduction du danger aux séismes.

ZUSAMMENFASSUNG

Die Unvorhersagbarkeit und Zerstörungskraft von Erdbeben sowie die sozio-ökonomischen Folgen des Versagens von Menschen errichteter Bauwerke führen mit jedem Erdbeben die Verantwortung des Bauingenieurberufs neu vor Augen. Die Versagensfälle der Vergangenheit haben gezeigt, dass die bauliche Gefährdung weltweit ohne Ansehen des technischen, kulturellen, sozialen oder wirtschaftlichen Entwicklungsstands existiert und entsprechend angegangen werden muss. Der Beitrag umreißt die fundamentalen Schritte zu einem rationalen und umfassenden Entwurfskonzept für Tragwerke mit reduzierter Anfälligkeit auf Erdbeben.



1. INTRODUCTION

Earthquakes around the world have repeatedly demonstrated, and will continue to demonstrate, the vulnerability of man-made structural systems to seismic input. Major earthquakes in recent years such as Mexico 1985, Armenia 1988, Loma Prieta (San Francisco) 1989, Philippines 1990 and Costa Rica 1991 have shown, with their devastating consequences in terms of loss of life, loss and interruption of regional infrastructure and damage to public and private property, that a global need for structural earthquake hazard mitigation exists independent of technical, cultural, social or economic development levels.

The civil and structural engineering challenge and obligation to mitigate seismic structural hazards has to concentrate on two major areas, namely (1) the design of new structural systems and (2) the assessment and retrofit of existing structures to withstand probable earthquakes within defined performance criteria. For new structural design in seismic zones, deformation based performance limit states have to replace force driven conventional design criteria, and performance specifications for individual structures have to reflect not only structural properties but, equally importantly, consequences of partial or complete failure if a meaningful earthquake hazard mitigation is to be achieved. The seismic rehabilitation of existing structural systems has to be based on the latest research findings due to the just recently evolving nature of retrofitting knowledge and basic retrofitting technology, preceded by a realistic seismic performance assessment of the as-built and the retrofitted structures. Both new seismic design and seismic retrofit have to evaluate structural systems and component behavior differently from conventional gravity and live load design principles which are mostly force driven and based on lower bound strength principles. Since the unpredictable earthquake load case typically develops and exceeds the inherent strength of a structural system, seismic design must ensure that (1) the structure can perform inelastically through the formation of defined mechanisms, (2) the mechanisms are of a ductile nature which ensures large inelastic deformations and energy absorption without significant loss of capacity and (3) the safety margin to other non-ductile or brittle mechanisms forming in individual components is clearly established. Only if these deformation and capacity criteria are clearly established and adhered to, can the structure be expected to survive an earthquake which exceeds the structural elastic capacity.

In the following, ideas and principles are summarized which form the basis for a rational comprehensive seismic design approach, and evolving procedures are outlined for the increasingly important seismic retrofit of existing and aging structural systems. Even though the principles presented are equally applicable to building, bridge and lifeline structures, the examples will concentrate on bridge structures damaged during the 1989 Loma Prieta earthquake due to the extensive nature of available as-built structural and research data. A general overview is provided on seismic structural problems followed by a discussion of their mitigation through new design and relevant assessment and retrofit measures for existing structural systems based on the latest research data.

2. SEISMIC STRUCTURAL PROBLEMS

Earthquakes show their devastating nature through damaged and collapsed man-made structural systems which in turn are responsible for loss of life, damage to regional infrastructure, and interruption of associated essential services. The three categories of structures supporting our socioeconomic systems are buildings, bridges and lifelines, and all three are equally affected by major seismic events.

The partial or complete collapse of buildings is typically a major source of earthquake related casualties, and can be attributed to various problem areas ranging from conceptual systems selection and design to the construction, usage and maintenance. Major earthquakes in China and Armenia with heavy building failures suggest problems with the selected structural system, i.e. unreinforced masonry or the structural systems connection detailing of prefabricated reinforced concrete buildings, respectively. Additional system problems frequently encountered in seismic building failures are pounding effects of adjacent structures, soft stories, irregular

geometry with significant stiffness changes in the horizontal and vertical directions, and inadequate footing performance. However, to label certain building systems as inherently unsafe has been proven wrong by the performance of similar systems in other earthquakes and by in-depth structural systems research. It is not an inherent fault with the selected structural system but rather an inadequate understanding of seismic input, seismic structural systems response and appropriate mitigating design principles.

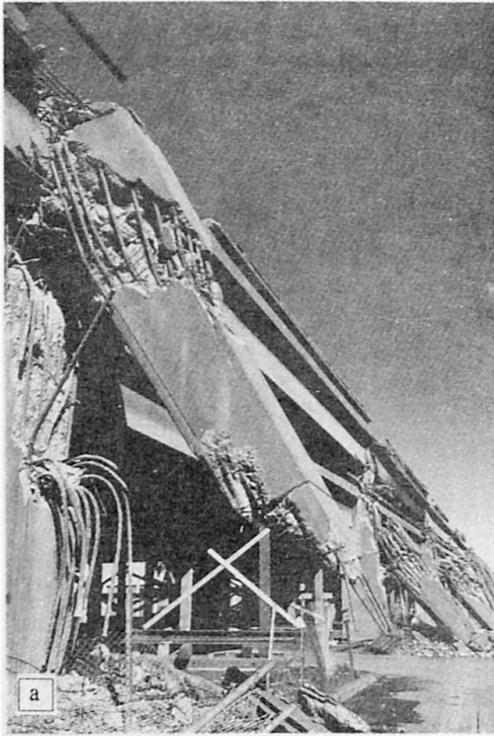

I-880
Oakland, CA
October 1989

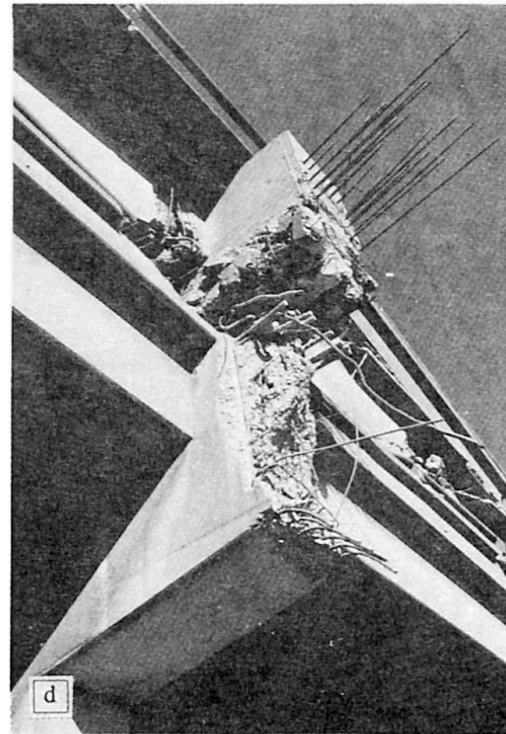

FIG 1. Bridge Damage During the 1989 Loma Prieta Earthquake

Bridge damage and/or collapse is noticed mostly due to its impact on traffic circulation patterns following a major earthquake. Quite often, it is the bridges most needed for post-earthquake search and rescue and relief operations which are collapsed or have to be closed. The duration of closure directly impacts the economic post-earthquake recovery of the affected region. Again, while many seismic bridge problems (see Fig. 1) can be associated with the choice of the structural system, the earthquake hazard also could have been mitigated by appropriate design



and detailing measures, [1]. Primary seismic problems in bridge structures include foundation and footing problems (e.g. liquefaction), expansion joint and seating problems due to lack of seat width and/or force constraint across the joint, inadequate member capacities in flexure and/or shear, lack of redundancy in the structural system to allow alternate load paths, and the detailing of joints between primary structural members such as footing/column connections, column/cap beam and cap beam/superstructure connections.

Loss of lifelines can be devastating both immediately during the seismic event, i.e. rupture of water reservoirs and dams, or following the earthquake in the form of fire danger from ruptured gas lines, disrupted water supplies to extinguish fires and epidemic sanitary and health problems from interrupted fresh and waste water systems.

Since the forces resulting from an earthquake in our manmade structural systems are unpredictable due to the unknown time, duration, epicentral location, magnitude, and dynamic characteristics, it is virtually impossible to design for these forces in a deterministic manner. Also, to design for the probable or most credible force levels elastically to prevent seismic structural damage is in most cases technically difficult and economically and aesthetically prohibitive. Thus, mitigation efforts have to assume that the structure will be loaded beyond the inherent force capacity and that inelastic action and damage will occur. However, this inelastic action can be controlled to occur in a ductile mode with known mechanisms at predetermined locations which still allow the system to deform and dissipate seismic energy without losing its critical function of sustaining gravity loads [2]. As part of a comprehensive seismic hazard mitigation design approach, not only the performance of the structural system but also the hazard in the form of ground motion and soil conditions and the consequences of structural failure in the form of potential loss of life and economic impact have to be evaluated in assessing the seismic risk of our manmade structures. In the following, some of these principles are outlined using bridge design examples, both for new designs and retrofit of existing structures.

3. SEISMIC EARTHQUAKE HAZARD MITIGATION

A comprehensive seismic structural hazard design approach should include the components of (1) Risk Assessment, (2) Equivalent Seismic Load Input, (3) Component Assessment and/or Design (4) Systems Evaluation, (5) Final Design or Retrofit. These components are schematically outlined in Fig. 2.

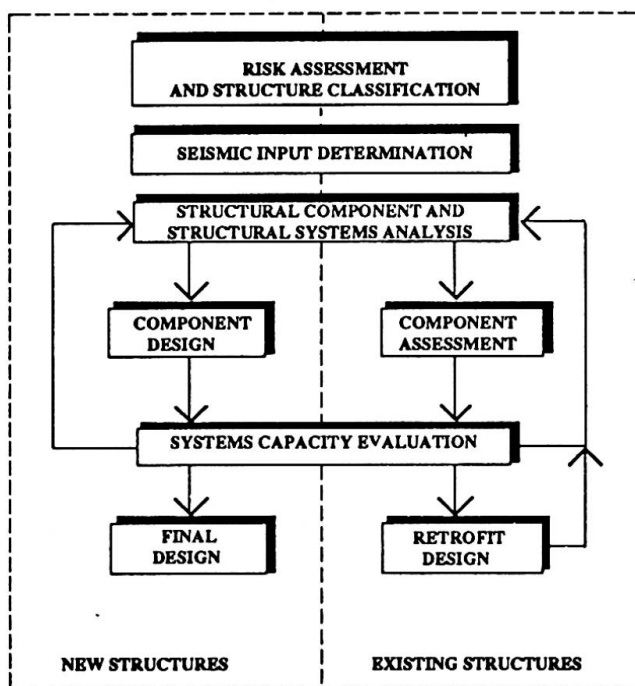

FIG 2. Seismic Design Process

The seismic risk assessment for a structure should involve the three principal components of hazard, structure and consequence. The hazard component reflects the probabilistic seismic input in terms of magnitude, probability of occurrence and soil/geological characteristics of the most probable seismic ground excitation. The structure component should address structural performance characteristics in terms of redundancy, detailing for inelastic action and critical geometry. Finally, the consequence component should address the importance of the structure and provide input on potential for loss of life consequences of failure or closure of the structure under evaluation. These three categories can be combined in a cumulative or multiplicative weighted risk algorithm to determine an estimate of the seismic risk for the structure. As an example of a risk assessment algorithm Fig. 3 shows the component and category tree structure currently used by

The derived elastic force reduction can now be used to establish an appropriate deterministic load input for the structural system in the form of acceleration response spectra which determine equivalent static seismic loads on the system.

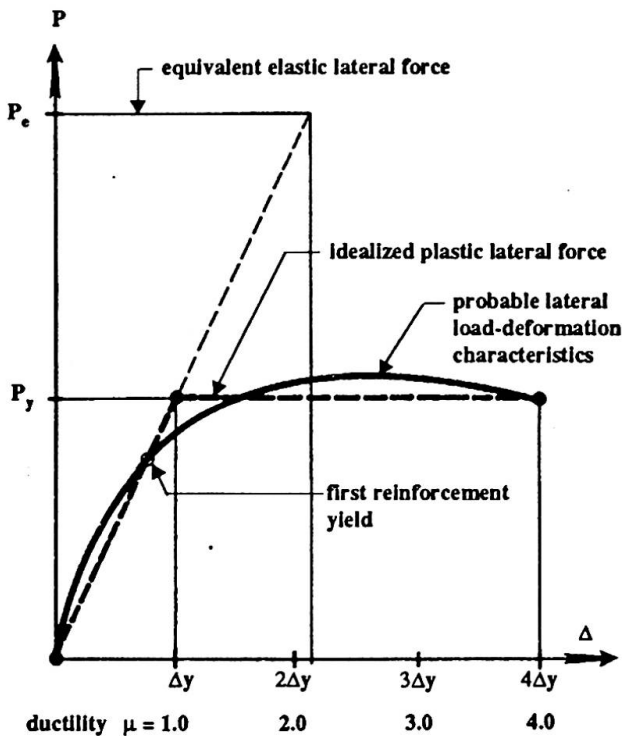

FIG 4. Load Deflection Behavior and Equivalent Elastic Forces

The actual member design for new structures and the assessment of actual member capacities for existing structures requires an evaluation of the most probable capacities of the component, i.e. a best estimate of the actual strength and deformation characteristics. Since in an inelastic design the earthquake will mobilize the inherent strength, a key design consideration has to be the formation of ductile mechanisms (not brittle shear or anchorage failures) which allow the structure to deform inelastically without significant loss of capacity. This design approach requires realistic capacity checks and comparisons of local mechanisms within each element and of adjacent joints, connections and members to ensure a global ductile systems mechanism. This capacity design concept was introduced by Park and Paulay [2] and finds increasing acceptance as one of the most powerful design tools in earthquake hazard mitigation. The same capacity based approach can also be applied to assess the seismic vulnerability of existing structures and to design, if necessary, appropriate retrofit concepts.

Based on this outlined design philosophy, new or existing structural systems can be designed, assessed, and or retrofitted, to allow various levels of inelastic deformation and damage as defined by the specified performance design limit states. An example of this capacity based approach is provided in the following example of a bridge assessment for one of the bridge structures damaged during the 1989 Loma Prieta earthquake.

4. ASSESSMENT OF EXISTING STRUCTURES

The key component in a comprehensive capacity based seismic design approach is the correct assessment of the component and systems behavior under combined gravity and seismic loads. Some of the principles involved in this assessment phase are outlined below in the examples of outrigger bents severely damaged during the 1989 Loma Prieta earthquake.

The realistic assessment of the component capacities and critical mechanisms of an existing bridge structure is based on the following steps:

1. Determine the most probable material properties; For existing concrete structures the actual concrete strength has significantly increased with time over the nominal design strength f'_c and reinforcement typically features higher yield than the specified nominal grade. Unless material tests on the existing structure are performed, assumptions of a 50% increase in concrete strength and a 10% increase in reinforcement yield strength are reasonable, i.e. $f'_c = 1.5 f'_{c,design}$ and $f_y = 1.1 f_{y,design}$.

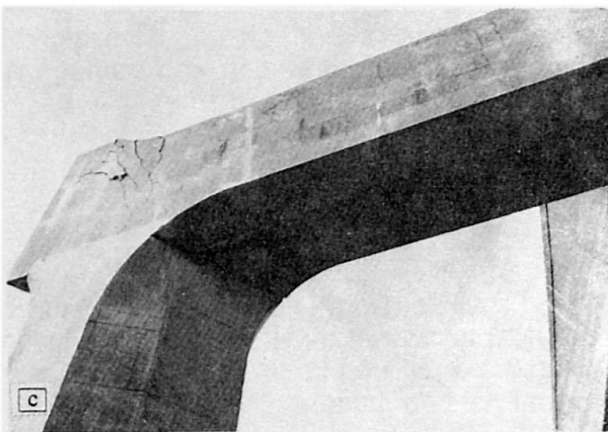
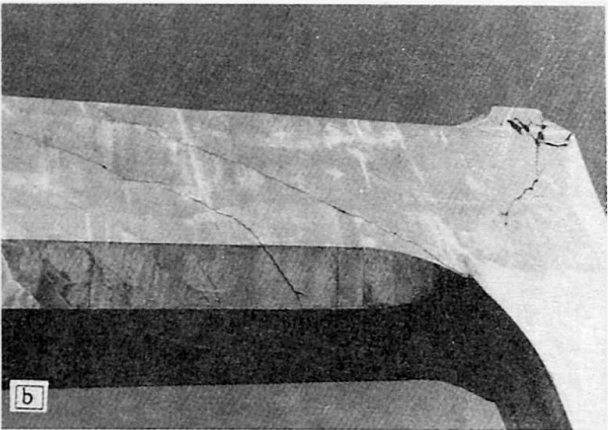
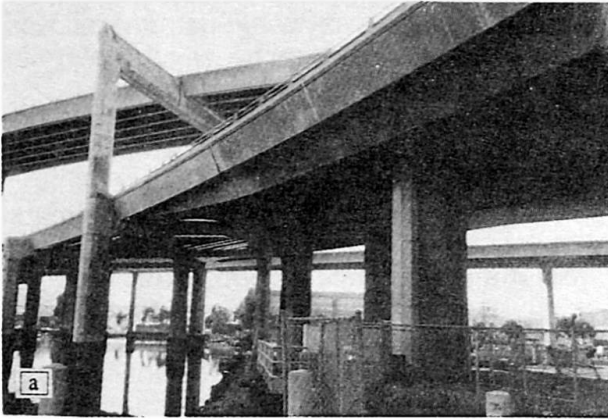

FIG 5. Earthquake Damage, Loma Prieta 89, China Basin Viaduct

2. Flexural capacities for the individual beam and column members are determined using above material properties and section analysis techniques which are based on a realistic concrete stress-strain relationship including axial load, confinement effects, and strain hardening. Flexural member capacities need to be adjusted where inadequate development length of the main reinforcement (see Fig. 1d) or lap splices with insufficient lap length or confinement limit the full capacity development under fully reversed cyclic loads. Detailed guidelines on the proper assessment of reinforcement development were proposed by Priestley [4].
3. The probable member shear capacities are determined, using a model which accounts for degrading concrete contributions with increasing ductility demand, truss action for stirrup reinforcement, and axial load effects from gravity loads or prestress as outlined by Priestley [4].
4. To determine the critical member mechanism, the plastic shear demand V_p of the member is determined based on full flexural plastic hinging and compared with the actual member shear capacity V_n . If $V_n > V_p$ a ductile flexural member failure mechanism can be expected. If $V_p > V_n$ the member might fail in a brittle shear mode prior to reaching its full flexural mechanism.
5. A combined gravity and earthquake (static lateral load) analysis of the complete gravity load support system or bent (beam - column assemblage) is now performed as a stepwise linear elastic event scaling procedure to determine the sequential formation of critical member mechanisms all the way to the critical systems collapse mode.
6. From the final global collapse mechanism, critical lateral load level and corresponding internal forces can now be determined. A check on joint shear in beam-column and column-footing connections and on footing capacities has to be performed with the obtained internal collapse loads based on capacity design principles [2] to ensure that no other degrading or brittle mechanisms develop in connecting or adjacent elements. If these capacity checks show deficiencies in the joints or adjacent members, appropriate systems load and deformation capacity reductions based on the expected level of cyclic degradation, see Priestley [4], have to be made.

7. The derived lateral load and expected deformation capacity for the structural system can now be compared to the required seismic load demand and the associated deformation or ductility design limit state as outlined in Fig. 2 to determine appropriate retrofit measures, as summarized by Priestley and Seible [5].

A general overview of the first outrigger bent on I-280 (China Basin Viaduct, San Francisco) is shown on Fig. 5a and damage patterns encountered during the earthquake are depicted in Figs. 5b and c. The as-built reinforcement details of the bent cap and columns are depicted in Fig. 6 and moment capacities and demands in the cap beam for separate and combined gravity and seismic loading are shown in Fig. 7. Following the outlined procedure, the bridge bent, shown in Figs. 5 to 7, was assessed [1]. Cap beam capacities were found well below corresponding column capacities and were thus critical for the overall seismic assessment. Member shear capacities were found to exceed flexural plastic shears. A unit lateral (seismic) load was applied to the bridge bent model and scaled to levels E_I and E_{II} where combined seismic and gravity loads form sequential mechanisms in the cap beam as shown in Fig. 7.

Lateral response force levels of $\ddot{E} = 0.63$ g and $\ddot{E} = 0.69$ g in the two directions, respectively, were found to cause complete global flexural mechanisms to develop. Particularly under loading to the right, see Figs. 6 and 7, the termination of negative or top reinforcement at a distance of 6.1 m from the column centerline is cause for the onset of a negative moment crack which propagates toward the column in shear aided by the lack of cap beam shear reinforcement in this region, see Fig. 6. A wide flexural-shear crack was observed in this region, as predicted, see Fig. 5c.

Joint shear cracking was calculated for both joints at lateral force levels less than those corresponding to the first flexural hinge formation. Approximate values corresponding to a joint shear stress of $0.33\sqrt{f'_c}$ MPa are $\ddot{E} = 0.45$ g; and $\ddot{E} = 0.40$ g, respectively. Thus, significant joint shear stress, as seen in Figs. 5b and c, can be expected. While the level of cracking visible in the positive knee joint moment regions of the bent cap beam indicated that the cap did not reach first flexural hinge formation, the shear stresses in the joints were high enough to cause joint failure. Hence the response accelerations appear to have exceeded 0.4 g in each direction. However, since both cap beam and joint mechanisms form at very similar lateral load levels and the distress pattern in the cap beam also reflects the reinforcement inadequacies, no repair or retrofit measure but rather complete replacement of the entire bent was recommended [1].

The second outrigger bent assessment example from the 89 Loma Prieta earthquake was performed for bent #38 on the I-980 southbound connector in Oakland, CA. Reinforcement details and dimensions of the critical knee joint are shown in Fig. 8. Based on capacity checks for both cap beam and columns, as outlined above, and from subsequent sequential failure mechanism analyses [1], the joint shear stress levels in the knee joint at the collapse limit state were found to be in excess of $0.5\sqrt{f'_c}$ and $0.35\sqrt{f'_c}$ [MPa] for closing and opening knee joint moments, respectively. Thus, joint shear damage can be expected prior to the development of any flexural ductile beam or column mechanism as demonstrated by the encountered distress patterns during the Loma Prieta earthquake, depicted in Fig. 9. Since existing beam and column capacities and reinforcement detailing were satisfactory to allow limited ductile performance, repair and retrofitting of the joint was performed by complete removal of the joint concrete, added joint shear reinforcement and an increased joint size.

While the above capacity based assessment examples were performed for existing bridge structures, similar capacity based procedures should also be employed in new structural systems design, see Fig. 2, to ensure ductile structural systems which allow seismic energy dissipation through well defined and appropriately detailed ductile mechanisms.

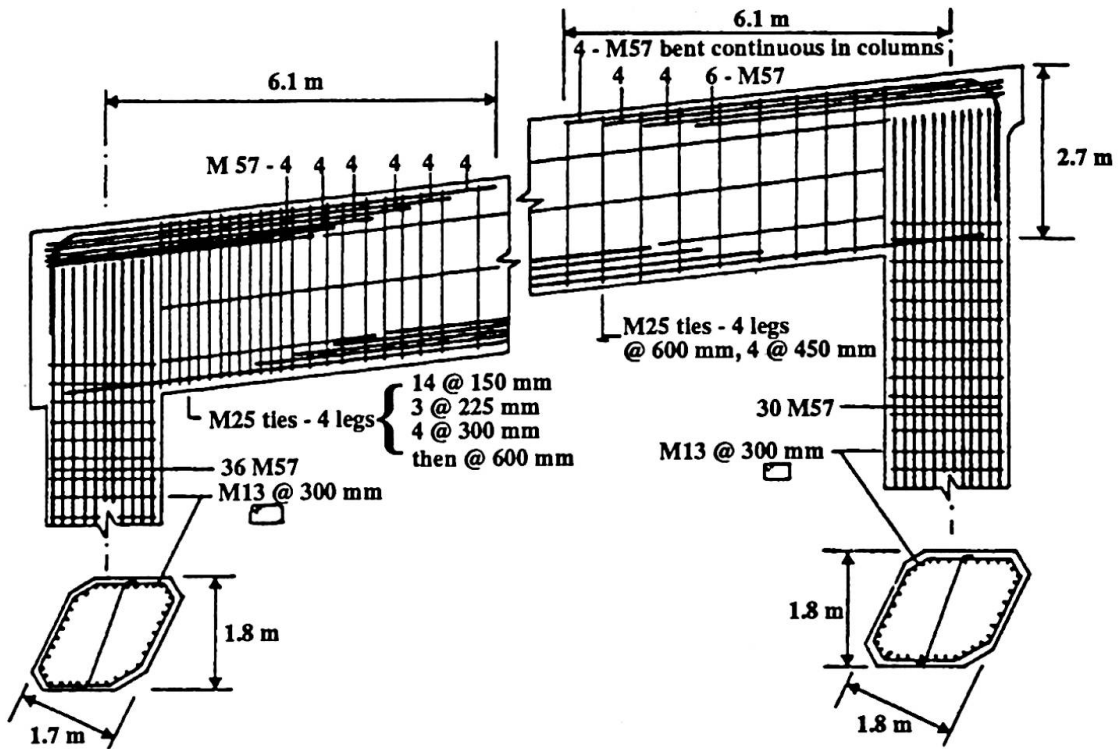

FIG 6. China Basin, Bent N₁-35 Reinforcement

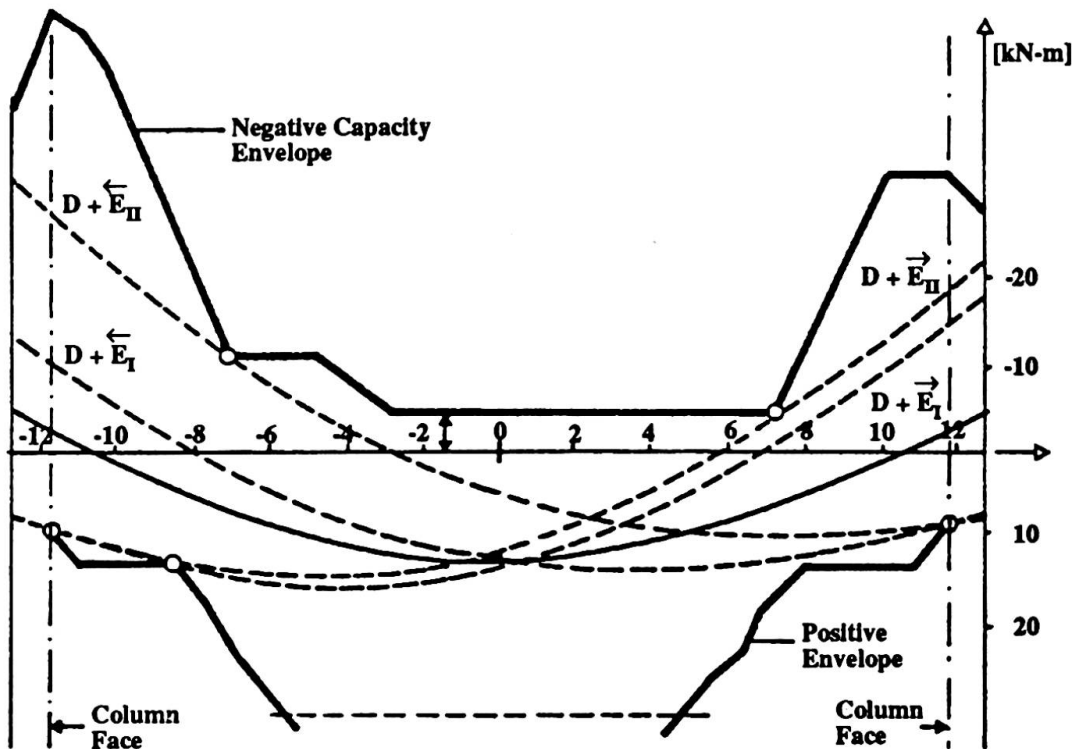

FIG 7. China Basin, Bent N₁-35, Moment Capacities and Demand

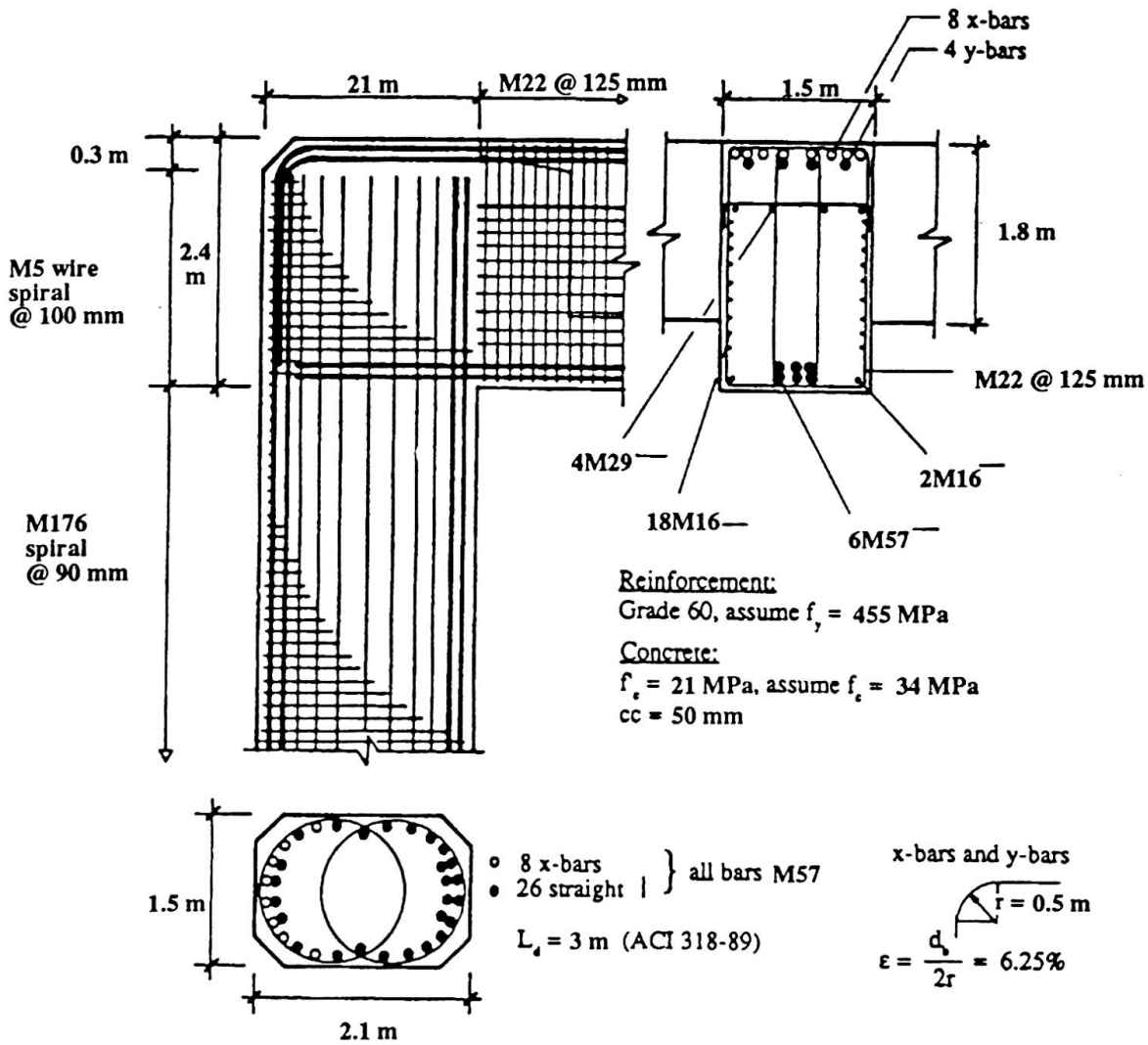

FIG 8. I-980, Bent #38 Reinforcement Details

5. CONCLUSIONS

To mitigate earthquake hazards arising from new or existing structural systems, a comprehensive seismic design and assessment approach is needed which accounts for seismic risk of the structure in terms of importance, consequence of failure, and probability of occurrence of the seismic design event. This seismic risk evaluation needs subsequently to be employed to define expected structural performance levels in the form of descriptive performance design limit states on one hand, and in determining appropriate design guidelines on the other hand. The deterministic portion of the seismic design process should be based on a capacity philosophy where local and global structural failure mechanisms are determined based on realistic or most probable materials and performance characteristics. The goal is to design a retrofit for the development of ductile well confined (flexural) plastic hinge mechanisms which will allow the structure to deform inelastically without significant lateral capacity deterioration. Capacities of adjacent members, connections and joints, have to be designed with sufficient margin to ensure flexural plastic hinge development considering axial load effects, concrete overstrength, confinement effects and actual reinforcement strength including strain hardening. Seismic structural design based on the above principles will allow a comprehensive and rational seismic structural hazard mitigation process.

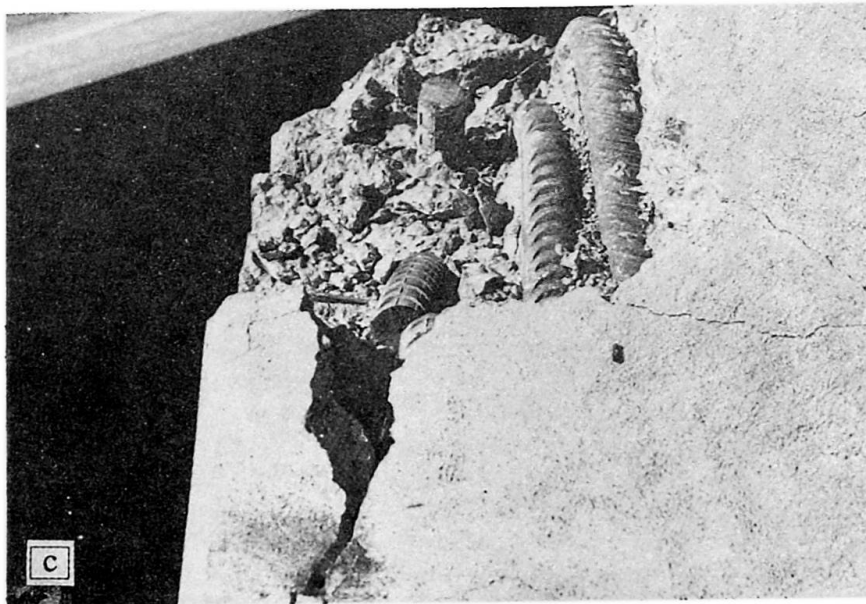
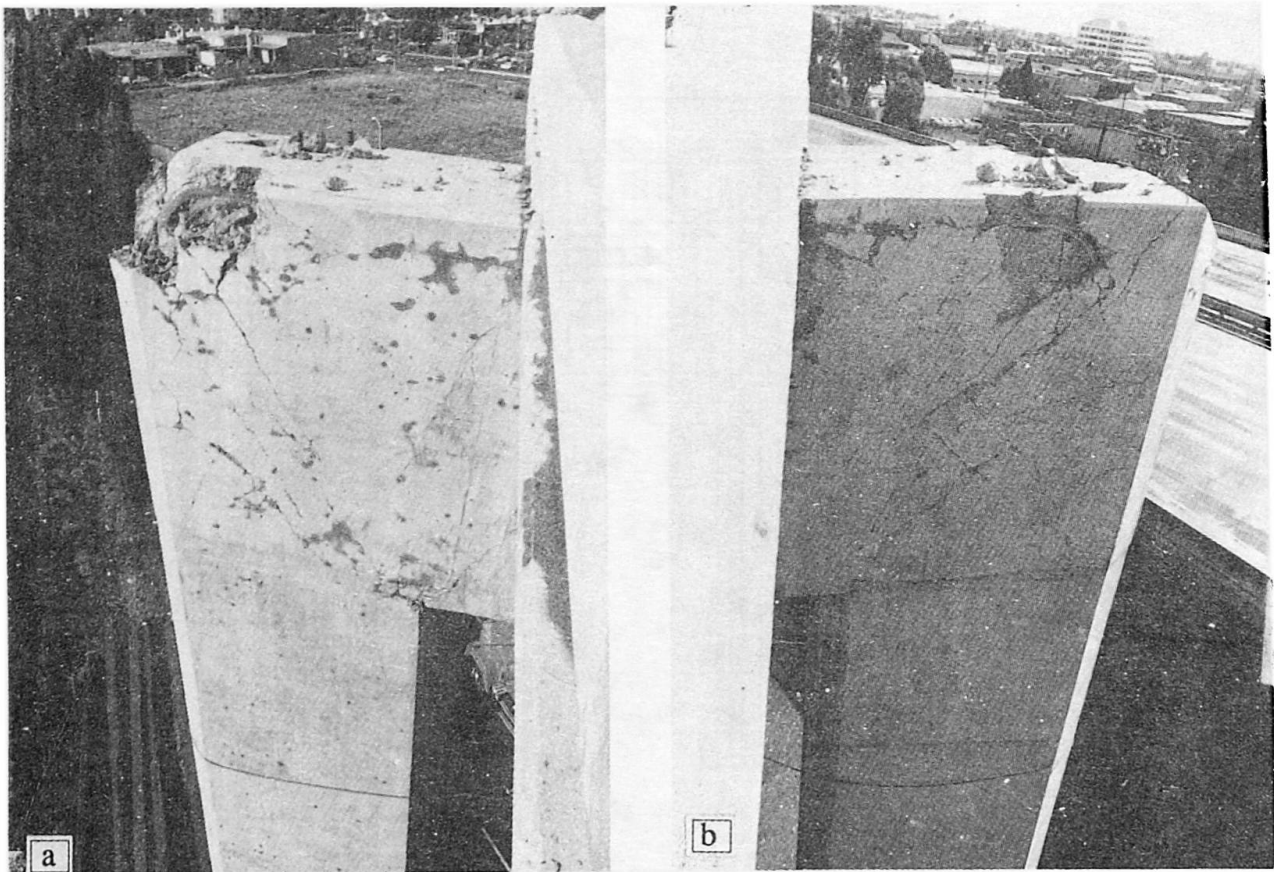

FIG 9. I-980 Oakland, CA, Encountered Damage Patterns

**REFERENCES**

- [1] PRIESTLEY M.J.N. and SEIBLE F., "Assessment of Bridge Damage During the Loma Prieta Earthquake," University of California, San Diego, Structural Systems Research Project, Report No. SSRP-90/01, March 1990.
- [2] PARK, R. and PAULAY T., "Reinforced Concrete Structures," John Wiley & Sons, New York, 1975, pp. 769.
- [3] MARONEY B. and GATES J., "Seismic Risk Identification and Prioritization in the Caltrans Seismic Retrofit Program," University of California, San Diego, Structural Systems Research Project, Report No. SSRP-91/03, July 1991, pp. 27-54.
- [4] PRIESTLEY M.J.N., "Seismic Assessment of Existing Concrete Bridges," University of California, San Diego, Structural Systems Research Project, Report No. SSRP-91/03, July 1991, pp. 84-149.
- [5] PRIESTLEY M.J.N., and SEIBLE F., "Design of Seismic Retrofit Measures for Concrete Bridges," University of California, San Diego, Structural Systems Research Project, Report No. SSRP-91/03, July 1991, pp. 197-250.

Leere Seite
Blank page
Page vide

Cyclone Resistance of Residential Buildings in the Caribbean

Résistance des immeubles résidentiels aux cyclones des Caraïbes

Auslegung von Wohnhäusern in der Karibik gegen Wirbelstürme

Robin W.A OSBORNE

Lecturer in Constr. Eng.
Univ. West Indies, St. Augustine,
Trinidad and Tobago

Ignatius D.C. IMBERT

Prof. of Constr. Eng.
Univ. West Indies, St. Augustine,
Trinidad and Tobago

Anil K. SHARMA

Senior Lecturer in Civil Eng.
Univ. West Indies, St. Augustine,
Trinidad and Tobago

David O. PREVATT

Research Assistant,
Univ. West Indies, St. Augustine,
Trinidad and Tobago

Cuthbert P. DRAKES

Research Assistant,
Univ. West Indies, St. Augustine,
Trinidad and Tobago

SUMMARY

The islands of the Caribbean are in a cyclone-prone area and annually suffer damage through the effects of high winds and rainfalls. This paper identifies some problems associated with residential buildings construction practice in the region which contribute to the extent of damage sustained by them. It also discusses the preliminary findings of a research project presently being conducted. This work includes regional housing surveys, wind tunnel model testing, structural tests and the development of a Cyclone Profile of the region. Items of future research activity are also identified.

RESUMÉ

Situées dans une zone à caractère cyclonal, les îles des Caraïbes sont chaque année l'objet de dégâts importants sous l'effet de vents soufflant en tempête et de trombes d'eau. Cet article souligne quelques problèmes liés à la pratique régionale de construction des bâtiment résidentiels, qui contribue à l'ampleur des dommages occasionnés. Il énumère par ailleurs les premiers résultats obtenus par un projet de recherche actuellement en cours. Cette étude comporte un relevé des immeubles d'habitation, des tests sur modèle réduit en tunnel, des essais structuraux et la mise au point d'un plan de découpage régional définissant le degré d'influence des cyclones. Ce projet délimite ainsi un certain nombre de points de la recherche future.

ZUSAMMENFASSUNG

Die Inseln der Karibik werden alljährlich von Wirbelstürmen heimgesucht, die Schäden durch hohe Windgeschwindigkeit und Platzregen verursachen. Der Aufsatz zeigt einige Probleme in der regionalen Bauweise, die für die Schäden an Wohnhäusern mitverantwortlich sind, und erörtert erste Ergebnisse eines laufenden Forschungsprojekts. Es umfasst eine Bestandserhebung der Wohnbauten, Windtunneltests, Tragwerksversuche und die Ausarbeitung einer Zonierungskarte für die Wirbelsturmgefährdung.



1. INTRODUCTION

The Caribbean Sea, in common with many other tropical areas worldwide, is subject to the seasonal passage of cyclones (hurricanes) which often attain highly destructive intensities. The area is also within a seismically active zone, and has been the scene of earthquakes and volcanic activity of severe intensity within recorded history. It has been hit by over 2000 cyclones¹ over the past 100 years of which 889 have developed to tropical storm or greater intensity. (See Table I). Reliable estimates of cumulative damage due to recent hurricanes are impossible to obtain, but they are thought to exceed US\$5 billion; the recorded loss of life this century is known to exceed 18,000 persons. It is reasonable to expect that had there been proper structural inputs into housing these figures would have been greatly reduced.

Recent hurricane occurrences have identified the particular but not exclusive vulnerability of a specific constituent of the built infrastructure: residential buildings, particularly those of the lower-income groups. The social disruption consequent on the passage of a severe Caribbean windstorm can be enormous, with large sections of the population left either homeless or roofless.

The resistance of dwellings (in particular) to such damage, and the possibilities for improving such resistance, are the focus of a current research project, which is at the preliminary stage of defining the major factors which are at work.

2. THE EFFECTS OF THE TROPICAL CYCLONE

The principal effects of tropical cyclones which affect economic activity, endanger the lives of populations in the region, and disrupt communication and transportation are: high winds, storm surges, super-elevated tides, and excessive rainfall. The islands suffer mainly from the high winds and accompanying rainfall and flooding. A hurricane event does not have to make landfall to cause significant damage since the bands of rain-bearing clouds can affect areas far removed from the centre of the event.

Table I Summary of Caribbean Tropical Storms and Hurricanes (1886-1990)

Type	Wind Velocity (km/h)	Total Number 1886 - 1990	Example	Date of Event	Island Affected
TS	63 - 118	368	Alma	Aug. 1974	Trinidad
HC 1	119 - 153	151	Katrina	Nov. 1981	Cuba
HC 2	154 - 177	174	Edith	Sep. 1963	St. Lucia
HC 3	178 - 209	108	Eloise	Sep. 1975	Hispaniola
HC 4	210 - 249	64	Flora	Sep. 1963	Tobago
HC 5	>249	24	Gilbert	Sep. 1988	Jamaica
Note: TS = Tropical Storm HC = Hurricane Category					

Typical damage occurs to the infrastructure such as roads, to communication lines as well as electricity and water utilities and to both engineered and non-engineered construction. Lower-income housing falls into the latter category; because of socio-economic conditions, construction tends to be done using the self-help method with its attendant lack of quality control.



3. POST-DISASTER STUDIES OF CYCLONE DAMAGE

Post-disaster reports have indicated that construction practice may contribute to the severity of damage from cyclones. Through regional post-disaster surveys after Gilbert and Hugo in 1988 and 1989 respectively, the evidence of poor connectors and inadequate structural-member sizes was found in many houses in Jamaica (1988) and Montserrat (1989). The loss to the economy of Jamaica, both insured and uninsured was in the order of J\$7000 million (US\$ 713 million at current exchange rate). Estimated damage² to Montserrat was put at US \$170 million. In Montserrat, insurance companies were called upon to settle 40 % of the insured value of buildings and 80 % of the contents.

In Jamaica after Hurricane Gilbert, roofing losses were estimated at 244,080 housing units, 30,235 homes being totally destroyed. The total value of these building losses was more than twice the total value of the entire construction expenditure for buildings that were constructed in Jamaica in 1987³.

4. THE CARIBBEAN REGION

The Caribbean Sea is an over-deepened, sub-oceanic basin including all the water north of South America and east of the Central American isthmus, south of the Greater Antilles and west of the Lesser Antilles of the West Indies. Its north-south width ranges from 610 km to 1125 km and its maximum length is more than 2400 km. The Caribbean Sea washes the shores of 19 independencies and many small islands. The islands of the West Indies have a total population of approximately 29.8 million people (1983) occupying a land area of 237,800 square kilometers. The average number of persons per household in the region is 3.4 giving a rough estimate of 8.76 million homes at risk of cyclone damage. This is the context for the Cyclone-Resistant Housing (Caribbean) Project, which is briefly described below.

5. THE CYCLONE-RESISTANT HOUSING (CARIBBEAN) PROJECT

The project is a joint research effort between the University of the West Indies (UWI), Trinidad, and the University of Waterloo (UW), Canada, funded by the International Development Research Centre (IDRC), Ottawa, Canada. The objective of the project is to improve through research, information dissemination, training and the construction of demonstration buildings, cyclone-resistant construction techniques and practice in the lower-income housing sector in the Caribbean region.

Major foci of the project to date have been (i) the collection and analysis of housing data, (ii) the preparation of a tropical cyclone profile based on the cyclone data collated over the past 105 years and (iii) wind tunnel and structural testing at the universities. The main activities and findings of the project to date are summarized in the following sections.

6. COLLECTION OF HOUSING DATA

6.1 Preliminary Survey of selected islands

The project has undertaken some preliminary surveys of the islands' housing with two goals in mind; (i) to determine the shapes and sizes of houses to be tested at the University of Waterloo and (ii) to gain an understanding of the methods by which normal house construction proceeds, with special emphasis on current fastener and connector details.

Four Caribbean roof shapes have been identified and are shown in Figure 1: the gable, the double lean-to, the hip and the monopitched. Eaves are common in all four house shapes with their lengths varying from 0.3 m to 1.2 m. Reports on Jamaican lower-income housing areas have shown the



most common roof types are the monopitched (40.4%), followed by the gable roof (28.4%) and the hip roof (21.6%). The double lean-to roof type was combined with all other types for a total percentage of (9.6%). It has been found to be common practice to include inset porches and verandahs of various sizes into these basic shapes.

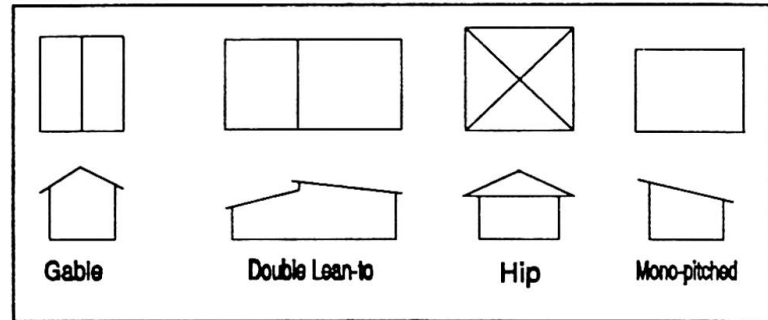

Figure 1 The most common housing shapes found in the West Indies

The most common form of roofing on houses in the region is corrugated galvanized iron sheeting fixed (using nails) to 25-mm x 100-mm timber purlins ("laths" - laid flat), which in turn are typically connected by one or two 75-mm nails to 50-mm x 100-mm timber rafters used on edge. The purlin and rafter spacing ranges from 750 mm to 1200 mm. The typical connection (rafter to wall plate, and rafter to ridge beam) in the above cases uses skewed or toe-nailed common iron nails, typically 75mm to 100mm long.

The lack of proper connections between wallplates and block masonry walls has been identified as the cause of many complete roof removals. In some instances, the wallplate merely rests on the wall embedded in a mortar layer. A major factor in the damage to housing subjected to extreme winds appears to be the loss of roof cladding which leads to significant loss of strength, and increased wind forces, which in many structures can lead to their structural collapse⁴.

6.2 Housing Assessment System

A methodology is being developed for the assessment of the cyclone-risk of typical single-family dwelling units. In determining this method, reference was made to international "deemed-to comply building standards"⁵ to compare the prescribed construction methods with those used throughout the region.

6.2.1 Wood-frame Construction

The construction techniques used in the Caribbean have developed more from traditional/cultural habits rather than through the application of sound engineering principles. For example, wood-frame buildings are clad with shiplapped or flat boards 19 mm thick. There is insufficient data available on the behaviour of this wall system under racking loads.

6.2.2 Masonry Construction

With regard to block masonry construction the practice in Trinidad and Tobago is the 100-mm thick unreinforced hollow clay block. In Jamaica 150-mm thick reinforced concrete block masonry is the tradition, and in Barbados 200-mm thick unreinforced concrete blocks are replacing the traditional 300 mm thick limestone blocks.

6.2.3 Foundations

The foundations of many older houses built on rented sites in the eastern Caribbean (eg. Antigua, Dominica) are neither fixed to the ground nor the house so as to facilitate the easy relocation of the house when the rental period expires. The supports used in such cases are usually of concrete



block, timber poles or boulders. Such practices as outlined above require careful analysis before prescribed construction methods can be applied in the region.

7. TESTING

7.1 Boundary Layer Wind Tunnel Tests

Based on counterpart work being done at the University of Waterloo within the project, pressure coefficients are being obtained for the roof, the external walls and the underside of eaves of the various scale model houses, from which the equivalent wind forces can be calculated on the actual structures. Of particular concern is the effect of verandahs (cut-outs) on wind forces, and the very low-pitched roof slopes often used (to save material) which increase roof-suction forces.

The wind code used by engineers in the region does not take into account house shapes such as those shown in Figure 1. The same can be said about other published wind codes or standards. It is therefore left to the engineer to determine the forces on the structure by other methods.

Results of the wind tunnel tests will be used at the University of the West Indies for setting up tests of various connections found from the field survey, and possibly recommending alternate connector details depending on availability, ease of installation, economy, and durability.

7.2 Static and Dynamic Testing of Structural Components

The interaction of the wind with buildings is usually of a dynamic nature. Since wind forces are generated in a randomly fluctuating manner this introduces the effects of fatigue to the various components and their connections. Therefore, the testing programmes at the UWI Structures Laboratory comprise both static and dynamic testing.

Tests currently being conducted are:-

- Static Withdrawal Tests of Sheeting Fasteners.
- Simulated Wind Loading on Corrugated Roof Sheeting and Fastener Assemblies (static; preliminary to dynamic testing).

8. THE CARIBBEAN CYCLONE PROFILE CHART

Using data on cyclone incidence, intensity and frequency for the period 1886-1990, a Cyclone Profile of the region is being developed. This follows similar work done in the United States and in Mexico for their respective areas. These profiles provide very useful information for policy-makers, engineers and the insurance industry. Figure 2 shows the geographical distribution of tropical cyclones represented by a series

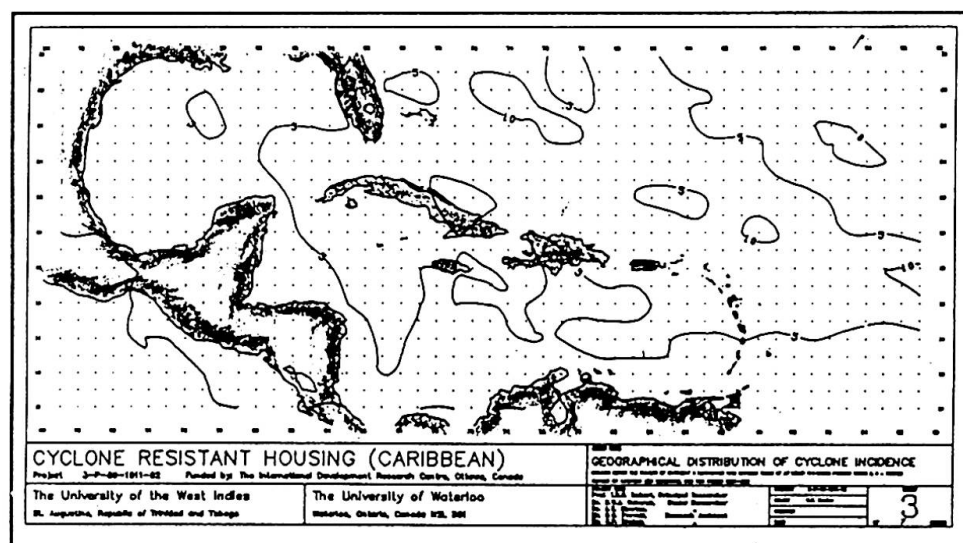

Figure 2 Geographical Distribution of Cyclones in the Caribbean (Hurricane Category 4).



of isolines drawn for Category 4 hurricanes. The isolines depict the number of tropical cyclone occurrences within a four-degree square of latitude and longitude. Similar charts have been developed for all tropical cyclones, and hurricanes of categories 1 to 5. The charts show the likelihood of landfall based on a statistical treatment of historical records.

The profile, together with topographic information of various islands, can be used to estimate: (i) the likelihood of cyclonic influence of a given intensity, and (ii) the likely aggravation of wind force by localized topography. This could be a useful input to the cost-effective structural design of residential units for particular locations within the Caribbean, having regard to stochastic as well as locational considerations.

9. SUMMARY OF FINDINGS

The structural engineering input to housing in the Caribbean has been very low for many reasons, (one of the main reasons has been the lack of enforcement of building codes). In cyclone-prone areas such as the Caribbean enormous losses can be sustained when a cyclone hits an area of poorly built houses. It is essential that we learn from past experiences and attempt to mitigate future residential damage and its consequent risk to human life.

1. Field studies have shown that many poor construction practices (especially inadequate connections) exist in the Caribbean, which increase the damage sustained during a cyclone event.
2. Wind Tunnel tests are necessary in order to develop design guidelines for the use of practising engineers in the design of Caribbean houses.
3. The Cyclone Profile is a useful tool for macro-economic planning and risk assessment related to housing settlements.
4. Adequate building code provisions and housing recommendations suitable for the Caribbean need to be available in a form usable by builders and self-help persons with minimum training and experience.
5. Funds for new housing are extremely scarce, moreso among the poorer classes. It is therefore essential to find means of retrofitting existing houses to improve their resistance to cyclones.

10. REFERENCES

1. NEUMANN, C.J., JARVINEN, B., PIKE, A.(National Hurricane Center, U.S.A.), ELMS J.D.(National Climatic Data Center, U.S.A.), Tropical Cyclones of the North Atlantic Ocean, 1871-1986 (3rd. revision), U.S. Dept. of Commerce - NOAA., Dec. 1990
2. GIBBS, T., BROWNE, H.(Consulting Engineers' Partnership), Hurricane Hugo in Montserrat. Reconnaissance Report on the Structural Damage, UNDP, Barbados, Nov. 1989
3. CLEMENT, D.B., Analysis of Disaster - Life after Gilbert, Institute of Social and Economic Research, The University of the West Indies, Jamaica, 1990.
4. WALKER, GEORGE R.(James Cook Univ. of North Queensland), Report on Cyclone Tracy - Effect on Buildings, Volume 1. Department of Housing and Construction, Queensland Australia, March 1975.
5. SOUTHERN BUILDING CODE CONGRESS INTERNATIONAL. Deemed to Comply Standard for Single and Multifamily Dwellings in High Wind Regions SSTD 10-90. Alabama., U.S.A., Dec. 1990

Structural System Reliability Analysis — The Key to Designing for Disasters

Analyse de la fiabilité des structures face aux catastrophes

Zuverlässigkeitsanalyse von Tragsystemen gegen Katastrophen

A.K. KARAMCHANDANI

Dr.
STUP Consult. Ltd
Bombay, India



Dr. A.K. Karamchandani obtained his Ph.D. from Stanford Univ. USA. His area of interest is safety of structures and he has been a consultant on this subject to organisations in India, Norway and USA. He is currently working on bridge engineering

SUMMARY

Structural systems are usually redundant and failure of an individual element does not constitute structural collapse. Therefore, for a realistic evaluation of the safety of a structure, one has to use systems reliability approaches in which the focus is on sequences of element failures leading to overall collapse. In this paper, insight gained from such systems reliability studies of offshore jacket platforms is presented. These include the advantages of x-bracing over k-bracing in extreme storms, selection of design waves to represent extreme storm loads, quantification of the benefits of redundancy for fatigue loads and safety under combined sources of risk.

RÉSUMÉ

Les systèmes structuraux ont en principe un caractère redondant et la défaillance d'un élément n'entraîne pas l'effondrement de la structure. En vue d'une évaluation réaliste de la sécurité du système structural, il est ainsi suggéré d'utiliser des méthodes d'étude de la fiabilité dans lesquelles l'essentiel consiste à opérer une succession de défaillances d'un élément qui entraîne l'effondrement total de la structure. Cet article présente un aperçu des études relatives à la fiabilité d'un système structural constituant les plates-formes de forage en mer proches du littoral. Il expose les avantages des contreventements en X sur ceux en K au cours de tempêtes de type extrême, la sélection de vagues modèles servant au calcul des charges extrêmes de tempête, la quantification des avantages de redondance pour les charges de rupture et la sécurité par combinaison des sources de risque.

ZUSAMMENFASSUNG

Tragsysteme weisen im allgemeinen eine Redundanz auf, dank deren das Versagen eines Einzelelements nicht zum Kollaps des Gesamtsystems führt. Eine wirklichkeitsnahe Analyse der Tragwerkssicherheit muss deshalb die Reihenfolge des zum Kollaps führenden Elementversagens berücksichtigen. Der vorliegende Beitrag stellt Erkenntnisse aus Zuverlässigkeitsanalysen aufgeständerter Offshoreplattformen vor, unter anderem die Vorteile von X-gegenüber K- Verbänden unter extremer Sturmeinwirkung, die Wahl repräsentativer Bemessungswellen, den qualifizierten Nutzen von Redundanz gegenüber Ermüdung und die Sicherheit unter kombiniert auftretender Gefährdungen.



1.0 INTRODUCTION

Ideally, a structure should be constructed to withstand every conceivable disaster without any damage. However, this is economically not possible. A more practical outlook, reflected in today's seismic design philosophy, is to design structures for two levels of loads. For disasters that are likely to occur during its lifetime, the structure is designed to survive without any damage whatsoever. However, in the case of a larger than anticipated disaster, the structure may undergo some damage, but it should not collapse and the loss of life should be minimal.

Traditional code based design has focused on the first level of safety, i.e., each individual member is designed to have adequate strength to withstand the maximum load anticipated during the life of the structure. However, when assessing the ultimate safety of the structure, one has to recognize that most structures are redundant and failure of an individual member does not usually constitute collapse. Hence, to evaluate ultimate structural safety, one has to go beyond the level of individual member failures and look at the problem from a **systems** point of view. Furthermore, because both the load and the strength of the structure are uncertain, one needs a probabilistic approach for a realistic evaluation of structural safety.

In the past decade there has been considerable development of such probabilistic systems approaches (Karamchandani, 1987). One especially useful approach is the "failure path approach". In this approach, the focus is on identifying sequences of member/section failures that lead to structural collapse. Typically, there are a very large number of such collapse sequences and therefore search techniques are used to identify the important sequences, i.e. the sequences that are most likely to occur. The probability of system failure is then approximated as the probability that one of these important sequences will occur.

There have been many applications of the failure path approach to structural problems in the past five years. In this paper, the focus is on insights gained from some of these applications—in specific, from a set of projects on offshore structures. These include comparison of alternate structural configurations, selection of wave load patterns for design, safety under fatigue loads and safety under combined sources of risk.

2.0 EFFICACY OF K AND X BRACING SYSTEMS FOR OFFSHORE STRUCTURES UNDER EXTREME STORMS

In the case of failure of an offshore steel jacket platform under an extreme wave in a storm, the critical elements are usually the braces. Typically, these are either in a "K" or an "X" configuration. To study the effect of these configurations on structure safety, Nordal et al., 1988, studied an eight-leg structure (Fig.1) with both "K" and "X" configurations for the bents (Fig.2). In both cases, the braces were sized using API (American Petroleum Institute) guidelines and a similar level of conservatism was maintained (i.e. the "unity" checks were similar).

In the analysis, the structure was modeled as a truss with the elements having piece-wise linear force - deformation characteristics (Fig.3). Note that after compression failure, the force in the element drops to a fraction (40%) of the value at failure. This is consistent with the fact that the braces are slender and buckle in compression.

The element capacities are treated as random variables. The mean values and standard deviations of these capacities are based on experimental test data. The wave load was modeled by a fixed pattern (corresponding to a 100 year design wave) and a random magnitude. The results of the analysis are presented in the failure trees of Figure 4 & 5. In these trees, each branch corresponds to failure of an element and each node corresponds to a damaged state of the structure. The number in the node is the possibility of reaching the corresponding damaged state, i.e., it is the probability of occurrence of the sequence of element failures represented by the branches leading to the node.

Note that the probability of an initial failure is much larger in the K-braced case, i.e. the effective strength of the brace in the X configuration is much higher. This is due to two factors. The first factor is as follows. The force in the brace in the X-configuration is due to both the extreme wave load and the dead load while in the Y configuration, it is only due to the extreme wave load. In the design process, an extra margin in strength is provided on the total force, e.g., in the X-case there

is a margin on the force due to the extreme wave and on the force due to the dead load. However, in the event of an extreme wave in a storm, it is unlikely that the dead load will also be excessive and therefore the extra margin for the dead load can be used to resist the force due to the extreme wave resulting in a larger effective strength. The second factor that causes a greater effective strength in the X-configuration is that the code is more conservative in predicting the strength of an X-brace.

It is also interesting to note that there is a large systems effect for the X-configuration, e.g., in the most important collapse sequence, the probability of occurrence of the full sequence is much smaller than the probability of occurrence of the initial failure. The systems effect is much less in the K-configuration. This difference is due to the difference in the post-failure behaviour of the K-configured panel and the X-configured panel. In both cases, the capacities of the braces are usually lower in compression and therefore the initial failure is typically a compression failure. In the K-configuration, due to static equilibrium constraints, the force in the tension brace is the same as in the compression brace. Hence, after a compression brace fails in the panel, the force in the tension member drops to match the post-failure drop in the compression member, i.e., the post-failure force in the panel is twice the post-failure force in the compressive brace.

The behaviour of the X-configured panel is very different. When the compression brace fails, there is no drop in the force in the tension brace - in fact it usually keeps increasing. In other words, the drop if any in the post-failure capacity of the X-configured panel is much smaller than the drop in the K-configured case. This leads to a larger ultimate system strength in the X-configured case and a correspondingly larger systems effect.

3.0 SELECTION OF CRITICAL WAVES FOR DESIGN OF OFFSHORE STRUCTURES UNDER EXTREME STORMS

Storms are a major source of risk for offshore structures and therefore, these structures are designed to withstand a large wave such as a 100 year extreme wave (i.e., the largest wave that is expected in a 100 year period). Due to the safety factors inherent in design, the structure will usually withstand this design wave with no damage and collapse will only occur under a much larger wave. The load pattern will be quite different for this larger wave. Therefore, basing the design on the load pattern corresponding to the smaller wave may be inappropriate.

This issue was studied by De, et.al., 1991, using the eight-leg jacket structure of Fig.1 (X-braced bents). It was found that if the pattern corresponding to a 65 foot wave (i.e. a 100 year design wave) is used and only the wave load magnitude is varied, then the critical members (which form the most important sequence) are in tier 2 (Fig.6). However, if a structural reliability analysis is carried out in which the wave pattern varies with magnitude (i.e. both are a function of wave height), then it is found that the structure is most likely to collapse under a 75 foot wave. The critical members for this wave are in tier 3 (Fig.7). In other words, for a typical offshore structure, the critical members in design may not be the members that are most likely to fail in an extreme storm.

4.0 RELIABILITY OF STEEL JACKET PLATFORMS UNDER FATIGUE

A large number of steel jacket offshore structures have exceeded their design life, but they are still being used as they are located on operational fields. Although many of these structures are safe with respect to extreme environmental loads, they are susceptible to fatigue failures. Studies have shown that due to the large uncertainties in fatigue strength, the probability of having a single member fail in an aging structure is quite high. Therefore there is growing concern about the safety of these structures.

However, these structures are redundant and therefore, due to systems effects, the overall safety may still be quite high. To quantify these systems effects, Karamchandani, et.al., 1992, studied a tripod structure located in the North Sea in a water depth of 70m and with an airgap of 22m (Fig.8).

Fatigue failures in jacket structures tend to occur at ends of members (i.e., at the joints). Hence, in the analysis, sections at both ends of the members were considered as potential failure sites. The failure path approach was used and the important sequences identified are shown in Fig.9.



It is interesting to note that the individual section that is most likely to fail has a failure probability of 0.00307 while the most likely collapse sequence has a probability of occurrence of 0.000058. Similarly, the probability of having at least one member failure (i.e., probability of any section failure in the intact structure) is 6.01×10^{-3} while the probability of system failure is 1.63×10^{-4} . Hence the conditional probability that system failure occurs given at least one section has failed in the intact structure is $1.63 \times 10^{-4} / 6.01 \times 10^{-3} = 0.027$. That is, even after an individual section has failed, the probability of system failure is quite small.

It should be noted that the tripod structure is not very "redundant", i.e., only two element failures are required for structure collapse. However, if a more redundant structure is considered (e.g. a six or eight leg jacket), then the systems effects will be even larger.

5.0 SAFETY OF JACKET STRUCTURES UNDER COMBINED SOURCES OF RISK

As seen in the above section, there are large systems effect in steel jacket structures subject to fatigue. Therefore, total structural collapse under fatigue loading may not be a critical issue. However, the probability of an individual member failing in fatigue is quite high and this may weaken the structure making it susceptible to failure under a large wave in a storm. This issue of a combination of sources of risk (i.e., an initial failure in fatigue followed by structural collapse under extreme wave) was studied by Karamchandani, et al., 1991 for the tripod structure of Fig.8.

A failure path approach was used and the important sequences identified are shown in Fig.10. The first failure is a fatigue failure and the second failure is a failure under an extreme wave. It is interesting to note that for the second failure, the members that are critical in the case of fatigue (second set of branches in Fig.9) are not the same as those that are critical under the extreme wave (second set of branches in Fig.10).

As expected, the probability of occurrence of the most likely sequence of combined failures, i.e., fatigue failure of section 680B followed by failure of member 620 under an extreme wave, is much higher than the probability of occurrence of the most likely sequence of fatigue failures, section 680B followed by section 611B (0.000217 versus 0.0000582). However, it is interesting to note that if one looks at the overall system failure probability in these two cases, the difference is much less (0.000234 for the combined case and 0.000163 for the case of only fatigue). In other words, the difference between the probability of occurrence of the most likely sequence and the probability of system failure is much larger for the case of two fatigue failures than for the case of a fatigue failure followed by a failure under an extreme wave. This is because the fatigue failures have low correlations while the failures under an extreme wave load are highly correlated. Note that in a more redundant structure which requires a larger number of element failures for overall collapse, the system failure probability for sequences of fatigue failures will greatly decrease (due to the low correlations of the fatigue failures). However, for such a redundant structure, the risk due to combined sequences (initial failure in fatigue and subsequent failures under an extreme wave) may not decrease because all the subsequent failures (under a single extreme wave) are highly correlated. Therefore, in more redundant structures, combined sequences of failures may be a much more significant source of risk.

References :

De, R.S., Karamchandani, A.K. and Cornell, C.A., "Offshore Structural System Reliability under Changing Load Pattern", Applied Ocean Research, 1991

Karamchandani, A.K., "Structural System Reliability Analysis Methods" Report No.83, John Blume Earthquake Engineering Center, Stanford, California, July 1987.

Karamchandani, A.K., Dalane, J.I. and Bjerager, P., - Systems reliability of offshore structures including fatigue and extreme wave loading", Journal of Marine Structures, 1991.

Karamchandani, A.K., Dalane, J.I. and Bjerager, P., "A Systems Reliability Approach to Fatigue of Structures", ASCE Journal of Structural Engineering, 1992.

Nordal, H., Karamchandani, A.K., and Cornell, C.A., "A System Reliability Case Study of an Eight-leg Jacket Platform", Technical Report RMS-3, Department of Civil Engineering, Stanford University, Stanford, California, April 1988.

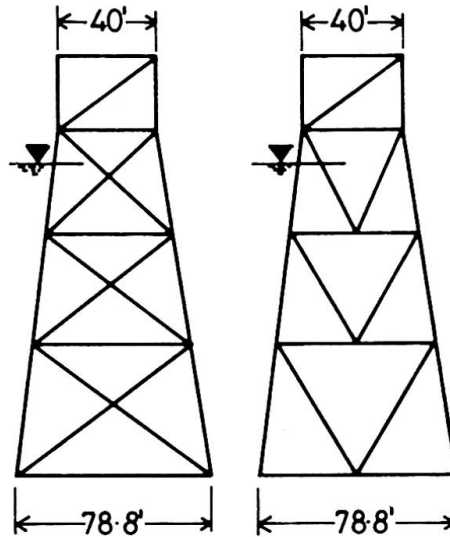
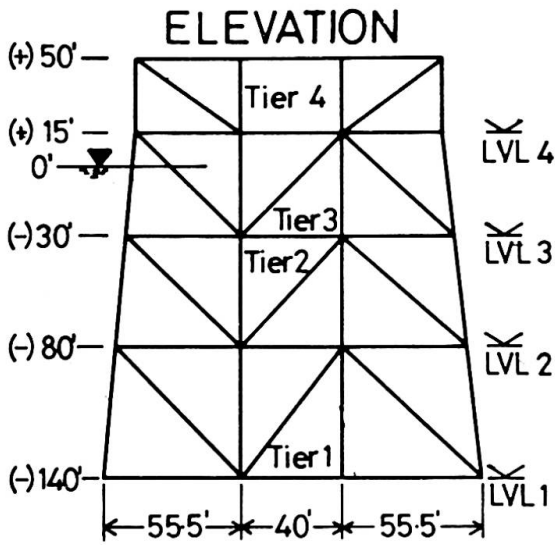

FIG 2: BENTS ALONG A, B, C, D

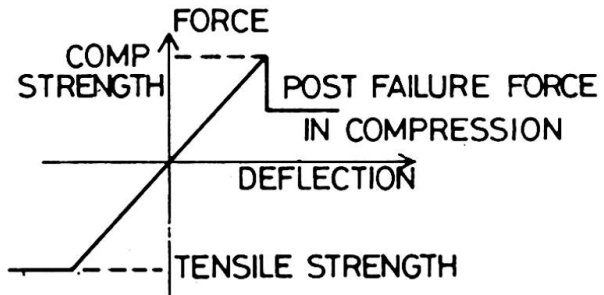
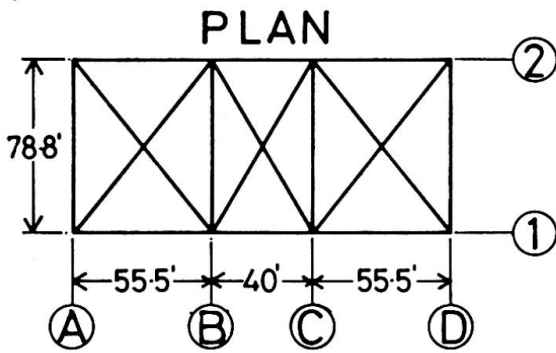

FIG 1: EIGHT LEGGED JACKED PLATFORM FIG 3: MEMBER FORCE DEFORMATION CURVES

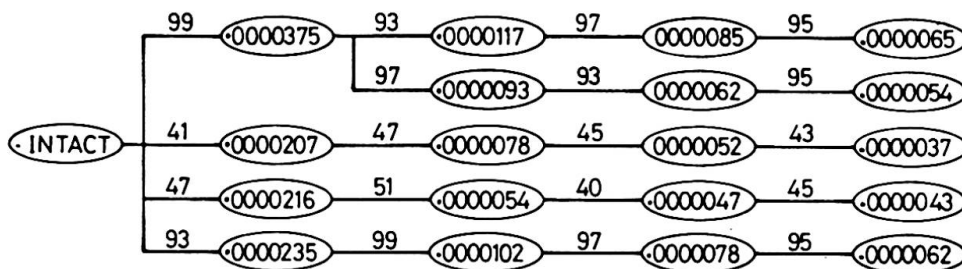

FIG 4: IMPORTANT SEQUENCES FOR THE X- CONFIGURATION

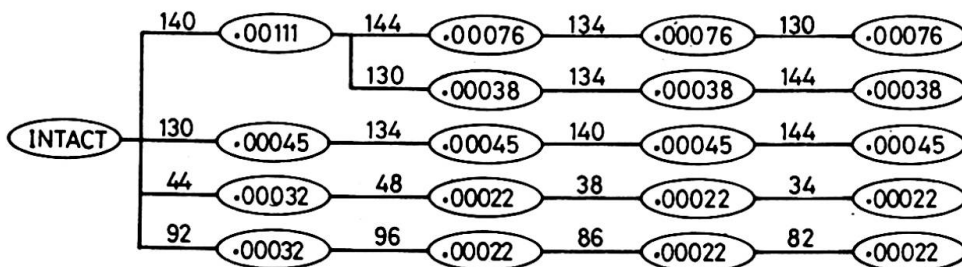

FIG 5: IMPORTANT SEQUENCES FOR THE K- CONFIGURATION

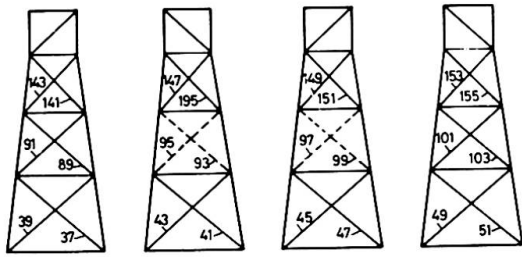

FIG. 6 CRITICAL ELEMENTS FOR ANALYSIS BASED ON 100 YEAR DESIGN WAVE

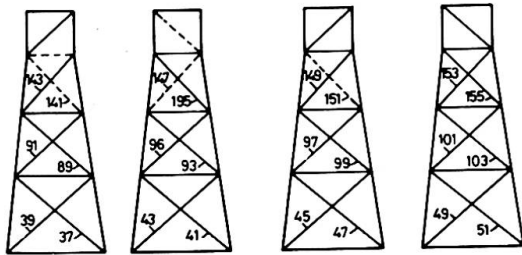

FIG. 7 CRITICAL ELEMENTS FOR ANALYSIS USING A VARIABLE WAVE LOAD PATTERN

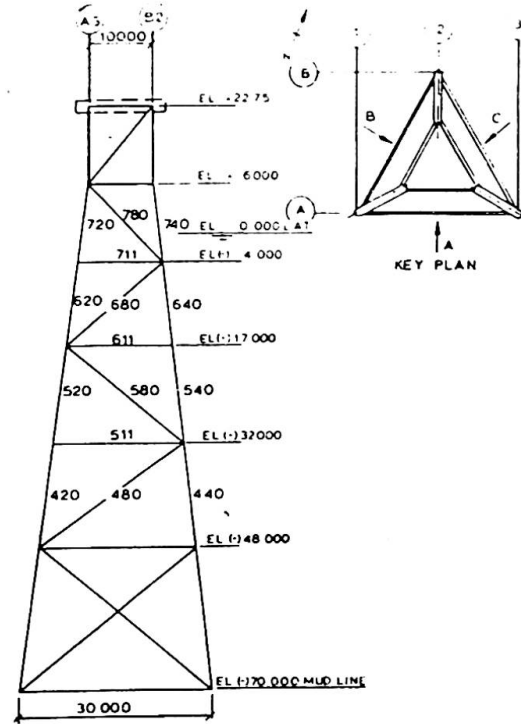
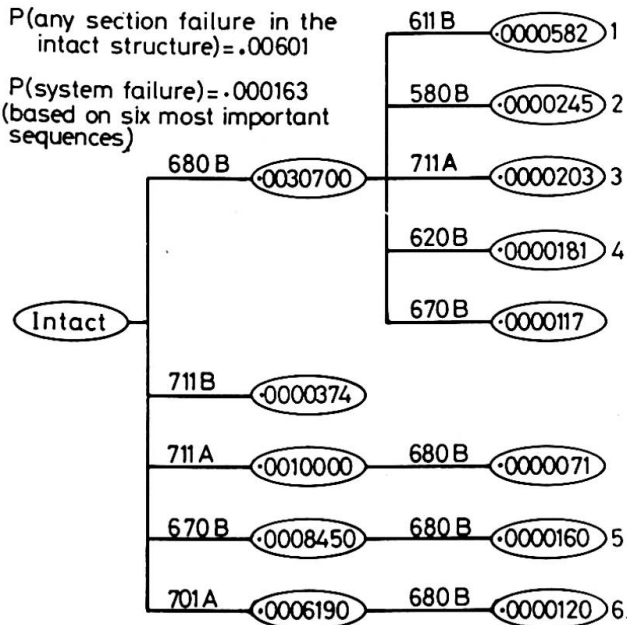
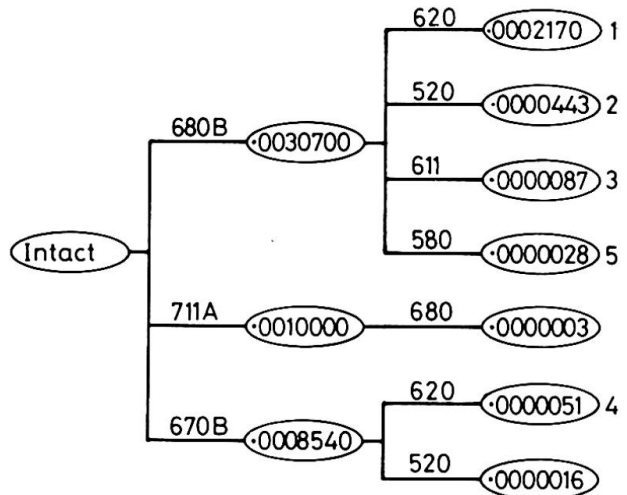

FIG. 8: TRIPOD JACKET PLATFORM



NOTE: The symbols A and B indicate the two ends of a member (e.g. 570 B is the section at end 'B' of member 570.)

Fig. 9 IMPORTANT SEQUENCES OF FAILURES IN FATIGUE.



$P(\text{system failure}) = .000234$
 (based on the five most important sequences)

Fig. 10 IMPORTANT SEQUENCES OF FAILURES UNDER FATIGUE AND EXTREME WAVES (ALL INITIAL FAILURES ARE IN FATIGUE AND SUBSEQUENT FAILURES ARE UNDER EXTREME WAVES)