

**Zeitschrift:** IABSE congress report = Rapport du congrès AIPC = IVBH  
Kongressbericht

**Band:** 14 (1992)

**Artikel:** Anchors: an efficient means for disaster resisting structures

**Autor:** Fischli, Franz

**DOI:** <https://doi.org/10.5169/seals-853208>

### **Nutzungsbedingungen**

Die ETH-Bibliothek ist die Anbieterin der digitalisierten Zeitschriften. Sie besitzt keine Urheberrechte an den Zeitschriften und ist nicht verantwortlich für deren Inhalte. Die Rechte liegen in der Regel bei den Herausgebern beziehungsweise den externen Rechteinhabern. [Siehe Rechtliche Hinweise.](#)

### **Conditions d'utilisation**

L'ETH Library est le fournisseur des revues numérisées. Elle ne détient aucun droit d'auteur sur les revues et n'est pas responsable de leur contenu. En règle générale, les droits sont détenus par les éditeurs ou les détenteurs de droits externes. [Voir Informations légales.](#)

### **Terms of use**

The ETH Library is the provider of the digitised journals. It does not own any copyrights to the journals and is not responsible for their content. The rights usually lie with the publishers or the external rights holders. [See Legal notice.](#)

**Download PDF:** 08.02.2025

**ETH-Bibliothek Zürich, E-Periodica, <https://www.e-periodica.ch>**

## **Anchors — an Efficient Means for Disaster Resisting Structures**

Tirants pour protection des bâtiments contre les catastrophes naturelles

Anker für Schutzbauwerke gegen Naturkatastrophen

**Franz FISCHLI**  
Civil Engineer  
VSL International Ltd.  
Berne, Switzerland

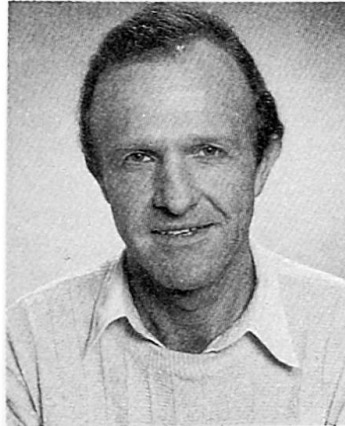

Franz Fischli, born 1945 got his civil engineering diploma at the Swiss Federal Institute of Technology, Zurich in 1971. With VSL international Ltd. since 1976 he has been involved in design, execution and development and is now head of the PR and Licensing section

### **SUMMARY**

Prestressed ground anchors have gained wide acceptance. Beyond the usual applications the anchoring technology is an ideal measure in connection with impacts caused by natural disasters. From the manifold applications this article describes how anchors were used to enhance the stability of buildings against typhoon wind loadings, how they increase the stability of dams and how easy and effective they can be used for gallery protection against rock fall.

### **RÉSUMÉ**

Les tirants d'ancrage précontraints ont fait leurs preuves partout et dans bien des domaines. Outre les applications habituelles, la technique d'ancrage représente une mesure idéale de protection complémentaire contre les effets des catastrophes naturelles. Parmi les nombreuses applications possibles, cet article décrit comment l'utilisation d'ancrages peut assurer la stabilité des bâtiments contre l'action de vents extrêmes, comment ils peuvent augmenter la stabilité des barrages et avec quelle simplicité et efficacité ils peuvent être utilisés dans la protection des galeries contre les chutes de pierres.

### **ZUSAMMENFASSUNG**

Vorgespannte Bodenanker haben sich überall und auf allen Gebieten bewährt. Neben den üblichen Anwendungen ist die Ankertechnik eine ideale Massnahme im Zusammenhang mit Schutzbauwerken gegen Naturkatastrophen. Von den vielfältigen Anwendungen beschreibt der Artikel, wie Anker die Stabilität von Talsperren erhöhen, und wie einfach und wirksam sie im Zusammenhang mit Steinschlaggalerien eingesetzt wurden.



## 1. INTRODUCTION

Prestressed ground anchors have gained wide acceptance and have established a permanent place in civil engineering practice. They are economical, easy and quick to install and, if appropriately designed using the latest state-of-the-art technology they are a reliable means for transferring forces to rock or soil, whether temporarily or permanently.

The most common uses for anchors today are for anchoring excavations and retaining walls, securing slopes and fractured rock zones and for stabilizing caverns. They are equally suitable for use in resisting uplift, anchoring concentrated forces and testing piles.

## 2. STATE-OF-THE-ART ANCHOR TECHNOLOGY

Within the scope of this paper it's not possible to fully treat today's state-of-the-art anchor technology or anchor recommendations and the reader is referred to relevant FIP publications ([1], [2]). It's an acknowledged fact that design and planning of anchors call for experience and know how and that the installation phase requires the skilled and qualified labour of the specialized anchor contractor. Modern anchors can be detensioned and restressed in a controlled way at any time during the life of a structure, a feature which should be decided and specified in the planning or design stage in advance of the anchor installation. The same applies where anchors are to be monitored after installation.

The necessity of adequate corrosion protection cannot be over emphasized. As a general rule permanent anchors should always be protected. The protective system should totally exclude the atmosphere from the tension member by completely encapsulating it within an impervious sheath. High density polyethylene is very often used as it meets all corrosion protection requirements and - in most countries - is readily available and cheap. The quality and integrity, however, greatly depend on the workmanship of key interfaces e.g. anchor head/free length and free length/tendon bond length.

## 3. DISASTER RESISTING STRUCTURES

Beyond the traditional applications mentioned above the anchor technology has for quite some time been used in connection with structures which either have to be secured against the effects of natural disasters, or which protect the environment from the effects of natural disaster, or which prevent the effects of natural disaster to take place at all. In all these cases anchors play a key role and it's therefore very important that the proper function of these anchors is monitored and that the anchor force can be adjusted.

## 4. EXAMPLES FROM PRACTICE

To illustrate the effectiveness of anchors in connection with disaster resisting structures some major and outstanding structures are described in the following. From the manifold applications two examples show how anchors assure the stability of buildings against wind, three on how they are used to strengthen dams against exceptionally high water levels, floods and earthquake movements and two on protective measures against rock fall.

#### 4.1 Anchors to enhance the stability of buildings

Two of the most spectacular buildings in Hong Kong, the Hong Kong and Shanghai Bank and the Bank of China owe their stability against typhoon wind loading (design wind velocity of 250 km/h) and ground buoyancy effects to permanent rock anchors.



Figure 1: Hong Kong and Shanghai Bank

The spectacular appearance of the Hong Kong and Shanghai Bank (Fig.1) was achieved by hanging the structure from 8 towers. Each tower comprises 4 braced steel tubular masts. In addition to the primary caissons forming the immediate foundation for these towers, the structure loads are also distributed to a series of secondary caissons to complete the substructure of the building. To provide stability against wind and ground buoyancy effects from the high water table a total of 314 permanent, restressable and monitorable anchors, ranging in working load from 650 to 2100 kN had to be installed. The maximum anchor length is 32 m. The design life of the anchors is 100 years.

The Bank of China which rises to a height of 315 m with 70 floors is presently the tallest building in Hong Kong (Fig. 2). The structure is reinforced concrete and steel framed with a composite metal tray and reinforced concrete floor system. The structural concept consists of a space truss which acts to carry both the vertical loads as well as the wind forces.

The substructure is comprised of a 1.0 m thick diaphragm wall, four massive 9 m diameter caissons located under the four main columns at the corners of the superstructure and a number of smaller caissons which support the super-structure. Due to its relatively light construction and height, permanent prestressed rock anchors were introduced into the foundation to provide both overturning resistance and to improve lateral shear capacity. A total of 77 rock anchors were located through the diaphragm wall and another 50 around the caissons. The caisson anchors had the additional task of providing restraint against hydrostatic uplift. (Fig. 3)

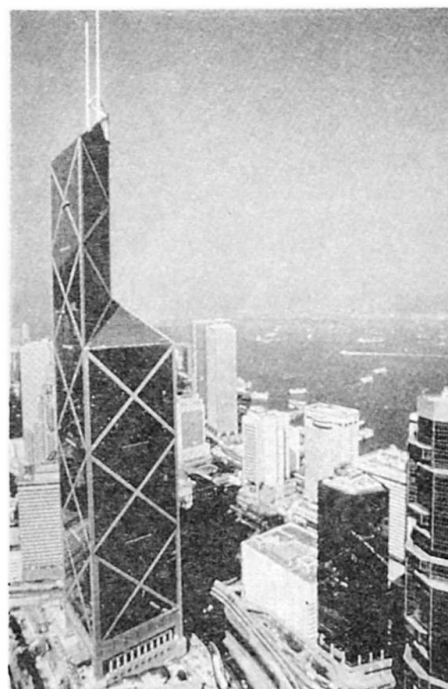

Figure 2: The Bank of China

Three different sizes of VSL permanent anchors were used in the works:

Type and Unit	Number of 0.5" strands	Number of Anchors	Ultimate capacity (kN)	Working load range (kN)	Longest net tendon length (m)	Bond Length (m)
EG 5-21	21	50	3,906	from 461 to 1,953	53.30	7.0
EG 5-35	35	63	9,275	from 2,164 to 4,638	70.25	10.5
EG 5-42	42	14	11,130	5,513 and 5,565	62.70	10.7



With a design life of 100 years, it was essential that the material and design concept for the anchor was fully verified by stringent testing prior to commencement of the actual works.

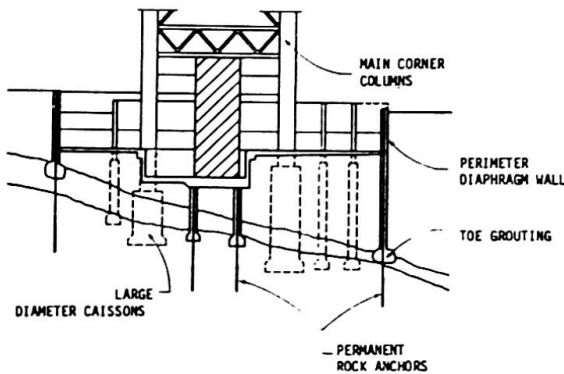

Figure 3: Schematic Section through Substructure and Foundation

After being homed the anchors were grouted both internally and externally. Once the grout had attained  $30 \text{ N/mm}^2$ , the anchors were stressed with a multistrand jack. In its final state a protective cap filled with grease was fitted to the anchor head. Over its design life the load in the anchor can be checked periodically with a load cell and if necessary adjustments to the anchor load can be made.

Prestressed anchors provide an economic and time saving solution for anchoring such structures. The alternative would have been only by introducing massive concrete foundations to increase the self weight or the excavation of multiple deep rock caissons to mobilize the rock.

#### 4.2 Anchors to increase the stability of dams

Some old concrete dams often no longer satisfy modern safety requirements in regard to stability at exceptionally high water levels, floods and earthquake movements. On the other hand dams sometimes need to be strengthened and rehabilitated, either because they are old and thus have suffered cracking in course of time or because earthquakes or landslides have impaired the integrity of the structure.

Anchors used to increase dam safety owe their continuous success to a variety of important and unique advantages:

- they don't interfere with normal reservoir storage and can be installed at short notice;
- they don't adversely affect the overall appearance of the dam as they don't require extra space;
- they are adaptable in length for rock and soil conditions;
- they are monitorable and adjustable with regard to their working force;
- and last but not least it's known from experience that anchors are more economical than alternative solutions.

At Mullardock Dam in the Scottish Highlands (Fig.4) a sudden and alarming increase in leakage caused by unusual cracks in the dam face was discovered some years ago. A three dimensional finite element analysis showed that stresses concentrated towards the central buttress section where cracks as wide as 1,5 mm were found.

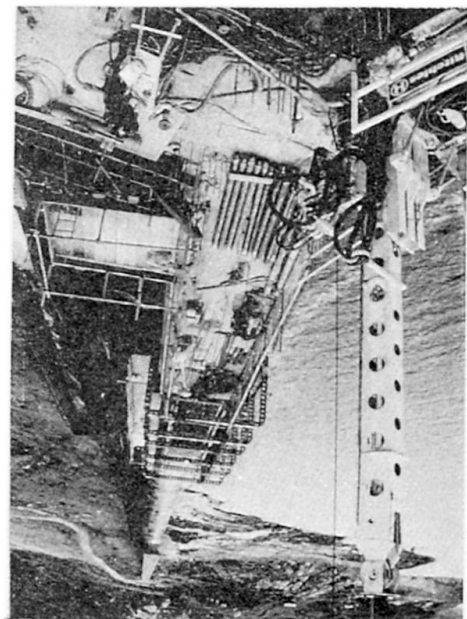

Figure 4: Anchoring at Mullardock Dam

Prestressed anchors proved to be the fastest and most economic solution to the problem and during 1990, 26 double corrosion protected, cement grouted anchors each with 37 no. 0.6" diameter dyform strands (ultimate capacity: 11,100 kN) and approx. 50 m long were assembled near the site, then airlifted to the crest of the dam by helicopter and directly hoisted into the drilling holes. On site acceptance tests with 3 load cycles followed for each anchor and finally left the anchors with a working load of 5,472 kN. A jumping load cell is used to monitor the behaviour, in particular the force consistency of the anchors.

The Sefid Rud Dam located approximately 200 km north-west of Tehran, Iran has undergone similar treatment. During June 1990 an earthquake of magnitude 7.3 struck the region between Zanzan and Rasth. The dam suffered extensive cracking at several locations, in particular horizontal cracks in the region 18 m below the crest. Rehabilitation work included anchoring of the upper part of the dam to the concrete body below the cracks by applying a load of about 100 MN to each of the 24 buttresses.

Installation of 234 VSL permanent rock anchors (including 40 monitoring anchors) each with an ultimate capacity of 14,078 kN and a working load of 8,447 kN began on March 3, 1991. The anchors each with 54 no. 0.6 " diameter strands have an inclination varying from 2° to 22° and are placed using a special homing device. Design bond length of the anchors is 12 m with an average overall anchor length of approximately 40 m. Stressing was completed on July 4, 1991.

Due to increased peak maximum flood levels the main wall of the Burrinjuck Dam (Fig. 5), located some 360 km south-west of Sydney, Australia was raised by a massive 13.2 m, which will result in a greatly increased spillway capacity. As for most similar cases in the past VSL permanent restressable anchors were used to secure the dam raising. The major rock anchoring work consists of installing 159 anchors each with 63 no. 0.6" diameter strands representing a minimum breaking load of 16,443 kN. The average anchoring force based on a wall crest length of 144 m and a design working load equal to 65 % of the rock anchor breaking load is 11,780 kN/m.

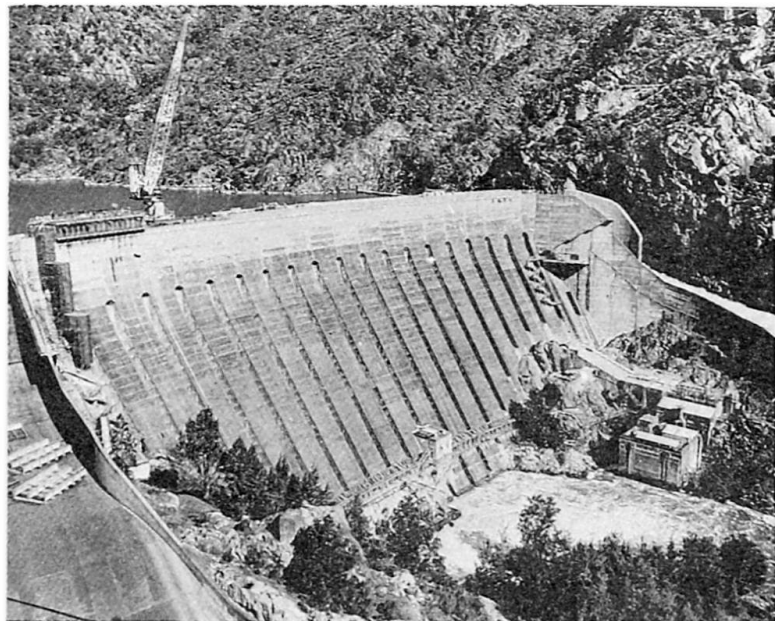

Figure 5: Burrinjuck Dam, Sydney

The anchors are arranged in two parallel rows along the crest in order to provide an acceptable spacing. To check on the performance of the anchor throughout its life the anchor design allows full load monitoring and load adjustment if required.

With a consumption of approximately 1,400 tonnes of high tensile strands the project represents one of the largest concentrations of anchoring force ever carried out in the world.



### 4.3 Anchors for gallery protection against rock fall and avalanches

The effects of erosion and the mechanical destruction of the rock caused by snow, ice, wind and rain very often leads to high risk of rock falls onto roads and railway lines. Various different types of rock fall and avalanche galleries have successfully been used to solve the problem. Two of them are located in Central Switzerland where rock anchors contributed to a very satisfactory solution. Near Hergiswil on Lake Lucerne the 160 m long gallery consists of unbraced free cantilevering slabs which are post-tensioned and anchored into the rock (Fig. 6). After installation of the anchors their stressing ends are provided with coupler heads to which the slab cables are connected. The anchors are 20 to 28 m long and were stressed to a working load of 3,314 kN representing 67,5 % of the breaking load.

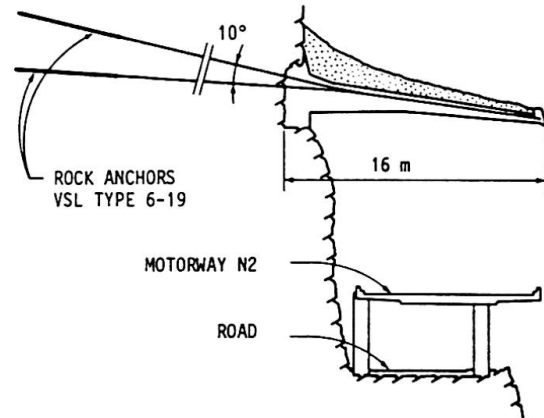

Figure 6: Rock fall gallery near Hergiswil, Lucerne

For the second gallery type (Axenstrasse, Central Switzerland Fig. 7) pre-fabricated elements were used to minimize the time during which the road had to be closed. The 1,300 m long main supporting structure is cantilevered out from the rock face and consists of upper main girders and lower struts. The upper foundation for the main girders was pressed directly against the rock face by two prestressed rock anchors every 5 m, each with a working load of 1,500 kN.

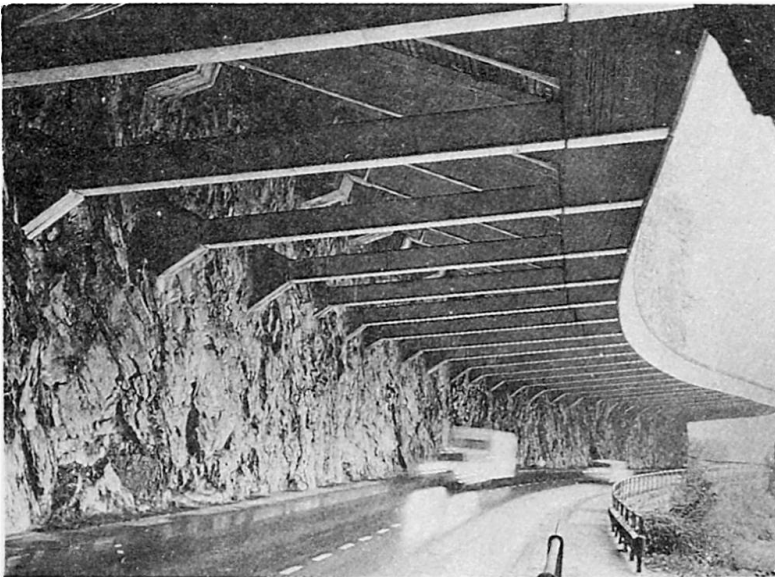

Figure 7: Axenstrasse, Central Switzerland

### REFERENCES

- [1] FIP, Fédération Internationale de la Précontrainte, State-of-the-art report "Corrosion and corrosion protection of prestressed ground anchorages", Thomas Telford 1986.
- [2] FIP, Fédération Internationale de la Précontrainte, "Recommendation for the design and construction of prestressed ground anchorages", Thomas Telford 1982 (under revision at the time of writing this article)