

Buckling of extraordinary deep and slender concrete box girders

Autor(en): **Das, Sankar C. / Huang, Tyau-Da / Zhang, Xianghui**

Objektyp: **Article**

Zeitschrift: **IABSE congress report = Rapport du congrès AIPC = IVBH
Kongressbericht**

Band (Jahr): **14 (1992)**

PDF erstellt am: **23.07.2024**

Persistenter Link: <https://doi.org/10.5169/seals-853230>

Nutzungsbedingungen

Die ETH-Bibliothek ist Anbieterin der digitalisierten Zeitschriften. Sie besitzt keine Urheberrechte an den Inhalten der Zeitschriften. Die Rechte liegen in der Regel bei den Herausgebern. Die auf der Plattform e-periodica veröffentlichten Dokumente stehen für nicht-kommerzielle Zwecke in Lehre und Forschung sowie für die private Nutzung frei zur Verfügung. Einzelne Dateien oder Ausdrucke aus diesem Angebot können zusammen mit diesen Nutzungsbedingungen und den korrekten Herkunftsbezeichnungen weitergegeben werden. Das Veröffentlichen von Bildern in Print- und Online-Publikationen ist nur mit vorheriger Genehmigung der Rechteinhaber erlaubt. Die systematische Speicherung von Teilen des elektronischen Angebots auf anderen Servern bedarf ebenfalls des schriftlichen Einverständnisses der Rechteinhaber.

Haftungsausschluss

Alle Angaben erfolgen ohne Gewähr für Vollständigkeit oder Richtigkeit. Es wird keine Haftung übernommen für Schäden durch die Verwendung von Informationen aus diesem Online-Angebot oder durch das Fehlen von Informationen. Dies gilt auch für Inhalte Dritter, die über dieses Angebot zugänglich sind.

Buckling of Extraordinary Deep and Slender Concrete Box Girders

Flambage des poutre-caissons très profondes et minces

Beulen ausserordentlich hoher und schlanker Betonhohlkästen

Sankar C. DAS

Assoc. Prof.
Tulane Univ.
New Orleans, LA, USA

Tyau-Da HUANG

Ph.D Candidate
Tulane Univ.
New Orleans, LA, USA

Xianghui ZHANG

Ph.D. Student
Tulane Univ.
New Orleans, LA, USA

Sankar C. Das, born in 1940, received BECE from Calcutta Univ. MS from Brown Univ. and MS and Ph.D from Univ. of Missouri, Columbia. Assoc. Prof. in Civil Eng. Tulane Univ. in the area of Structural Mechanics, he is currently doing research on buckling of slender concrete box girders.

Tyau-Da Huang, born in 1953, is a registered professional engineer at Avondale Industries, Inc, and a Ph.D. candidate in the Civil Eng. Dep. at Tulane Univ. He received his B.S. in 1976 from National Chung-Hsing Univ. Taiwan, and his M.S. from Ohio State Univ. Columbus, Ohio.

Xianghui Zhang, born in 1964, got his BS and MS in Engineering Mechanics at Shanghai Jiao Tong University. Presently he is working towards the Ph.D degree.

SUMMARY

It is necessary to consider the stability problem of very long-span deep and slender concrete box girders or concrete folded plate structures. The computer-based nonlinear finite element numerical technique involving large deflection theory, nonlinear material characteristics, cracking, concrete rebar interface etc. is used for the calculation of the instability of reinforced concrete plate elements and folded plate model.

RÉSUMÉ

Il faut considérer le problème de la stabilité des poutres-caissons profondes et minces de très longue portée ou des structures en béton faites en plaques plissées. Un programme d'éléments finis non linéaires tenant compte des grandes déformations, des propriétés non linéaires des matériaux, de la fissuration et de l'interface acier-béton a été utilisé pour le calcul de l'instabilité des plaques et plaques plissées en béton armé.

ZUSAMMENFASSUNG

Es ist notwendig, das Stabilitätsproblem sehr langer, hoher und schlanker Stege von Betonhohlkästen zu betrachten. Für ihre Stabilitätsberechnung als Stahlbetonscheiben und -faltwerke werden numerische Verfahren der Finite-Element-Methode eingesetzt, die die Nichtlinearität infolge grosser Deformationen, hoher Materialausnutzung, Rissbildung, Verbundschlupf usw. berücksichtigen.



1. INTRODUCTION

Reinforced and prestressed concrete panels are commonly used as structural elements of large box girder bridges, folded plate roofs, etc. Very deep and slender concrete box girder sections may be considered as thin folded plate structures and it is conceivable that some form of buckling may take place under the action of various load combinations, smaller in magnitude than those methods which do not consider stability. Complex geometric shapes and the concrete material with stress-strain relationships exhibiting different behaviors in tension and in compression of the above mentioned structures, effective and useful prediction of buckling response or post-buckling load carrying capacity via analytical approaches is generally very difficult. Therefore, numerical means such as the nonlinear finite element method is used in this instability study.

Separate modeling is used for the rebar and the concrete. Rebar is treated as an elastic-plastic metal. The concrete itself is modeled with an elastic-plastic-failure theory due to Chen and Chen's model [1,2]. This is an associated flow, isotropic hardening theory based on the yield surfaces written in terms of the first two stress invariants and parameters which are chosen to fit uniaxial and biaxial yield and failure data.

2. STRESS-STRAIN RELATIONS OF CONCRETE

A plasticity model originally developed by Chen and Chen [1,2] is utilized to represent the stress-strain response of concrete. The model consists of a compressive yield/flow surface to model the concrete response in predominantly compressive states of stress, together with damaged elasticity to represent cracks that will occur at a material calculation point.

The model thus uses the classical concepts of plasticity theory: a strain rate decomposition into elastic and inelastic strain rates; elasticity; yield; flow and hardening [1,2,3,8]. Cracking dominates the material behavior when the state of stress is predominantly tensile. Cracking failure is defined by the maximum principal strain reaching a critical value, with cracks normal to that direction. In cracked zones a strain softening model is assumed for the direct stress across the cracks, and for the shear stiffness. Subsequent to cracking failure, elastic-plastic calculations are continued in a reduced stress space containing those components not associated with the crack normal direction so long as the cracks are open. The basis of the post cracked behavior is the brittle fracture concept of Hilleborg [4]. The uniaxial behavior of concrete is shown in Fig. 1 and failure surfaces are shown in Fig. 2.

3. MODELING OF REINFORCEMENTS

It is intended that reinforced concrete modeling be accomplished by combining standard elements, using the plain concrete model with rebar elements, defined singly or embedded, that use one dimensional strain theory. This modeling approach allows the concrete behavior to be considered independently of the rebar. The nonlinear effects of the rebar and concrete interface, such as dowel action and aggregate interlock were modeled through the uses of "tension stiffening" and "shear retention strain" [1 thru. 3] which will simulate the load transfer across cracks through the rebars.



4. NUMERICAL ANALYSIS

The constitutive relations of reinforced concrete outlined in references [1, 2] have been implemented into a nonlinear finite element program ABAQUS [3] for application purposes. ABAQUS is a nonlinear incremental finite element structural analysis program for large strain and large displacement problems. The program provides a general interface so that the user may introduce own material constitutive model in a "user subroutine". To illustrate the applicability of the above constitutive model, the buckling responses of fourteen reinforced concrete rectangular plates and of a long-span reinforced concrete folded plate model were examined by the finite element analysis [5,6,7,8]. The reason for choosing these R.C. rectangular plates and the folded plate model for the analysis is that the experimental data are available for comparison [9,10,11].

4.1 Rectangular plates

Fourteen rectangular reinforced concrete plates selected [5,6,8] for nonlinear buckling analysis, have the dimensions as shown in Fig. 3, 4 ft. (1,219 mm) x 8 ft. (2,436 mm). They are reinforced by two layers of welded wire mesh. The eight node thin shell elements, S8R5 (5 D.O.F. per node) with four integration points on the surface and nine integration points through the thickness of the element are used in the finite element model. Various plate thickness, reinforcement ratios, maximum concrete compressive strengths, and the comparison of experimental buckling and post-buckling results with that of nonlinear numerical results are summarized in reference [5,6,8]. The maximum load-deflection plots, buckling-load points, and the post buckling load points for the plates no. 19 and 23 are shown in Figs. 4 and 5. The plot of non-dimensional buckling stress versus slenderness ratio and the comparison of experimental results with that of F.E. results are shown in Fig. 6 [5,8].

Plate No. 19 [Plate thickness, 0.757 inch; nominal steel area ρ , 0.50; cyl. strength, 3,448 psi]

Buckling Load

Experiment-70.1^k (314.05kN)
F.E.-65.0^k (291.2kN)

Post-buckling load

Experiment-84.9^k (380.35kN)
F.E.-80.9^k (362.43 kN)

Plate No. 23 [Plate thickness,0.763 inch; nominal steel area ρ , 1.0; cyl. strength, 3,396 psi]

Buckling Load

Experiment-70.0^k (313.6kN)
F.E.-68.2^k (305.54kN)

Post-buckling load

Experiment-78.0^k (349.44kN)
F.E.-79.8^k (357.5kN)

The numerical buckling and post buckling analysis [5,6,8] of R.C. rectangular plates agreed very well with that of experimental results [9,10].

4.2 Long-span reinforced and prestressed concrete folded plate model

A uniformly loaded post-tensioned lightweight concrete folded plate unit was tested by I. Martin [11]. During the experiment, a buckling failure mode was detected. The overall dimensions of the model is shown in Figs. 7 and 8. To solve the problem numerically, a finite element model (Fig. 9) is developed and more than forty-five nonlinear incremental analyses are performed through the computer program ABAQUS [3]. There are 84 elements and 293 nodes in the model. Material properties given [11], and other estimated values [1,2,3] for the constitutive formulations of concrete and steel are shown in Tables 1 and 2. The results of the analysis are shown in Figs. 10 thru 13.



Buckling Load

Experiment-34.0 psf (1,628 Pa)

F.E.-31.9 psf (1,527 Pa)

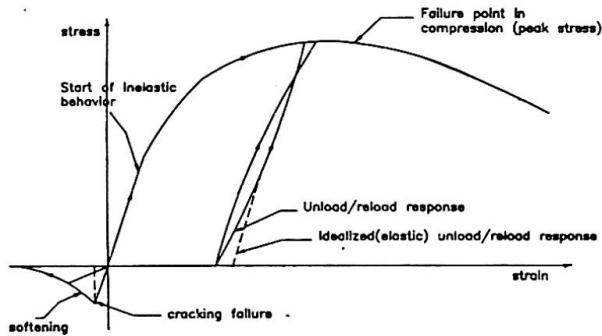

Fig. 1 Uniaxial Behavior Of Plane Concrete

Post-buckling Load

Experiment-Not available

F.E.-38.8 psf (1,858 Pa)

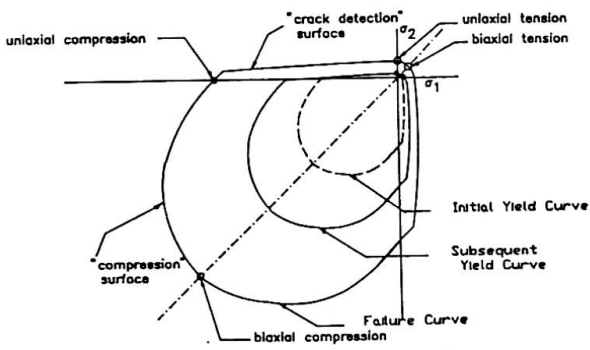

Fig. 2 Concrete Failure Surfaces In Plane Stress

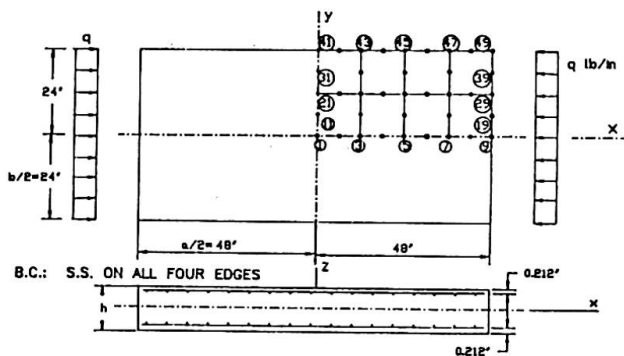

FIG. 3. F.E. Plate Model with Coordinate System (1 in = 25.4 mm)

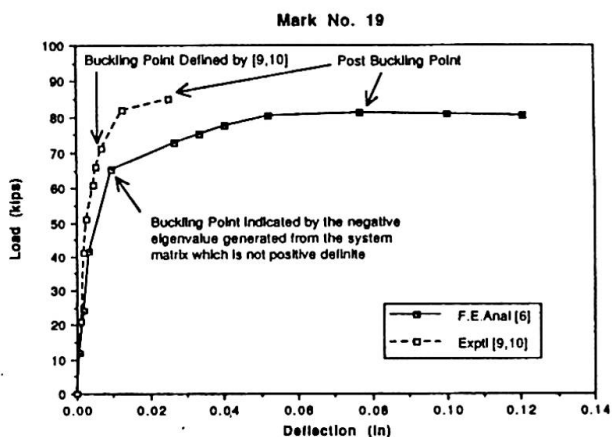

FIG. 4. Deflection at Node 1 in Z-direction (1 in = 25.4 mm; 1 kip = 4.48 kN)

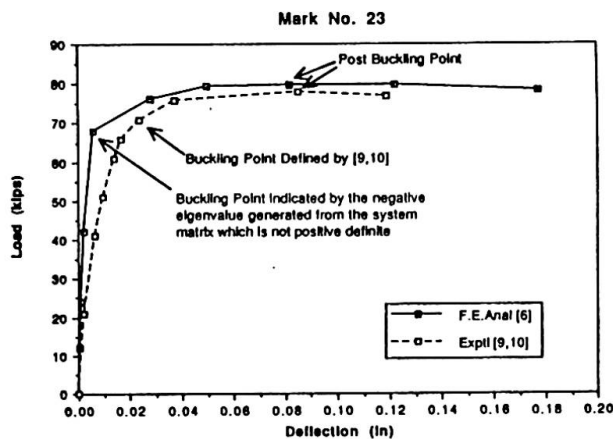

FIG. 5. Deflection at Node 1 in Z-direction (1 in = 25.4 mm; 1 kip = 4.48 kN)

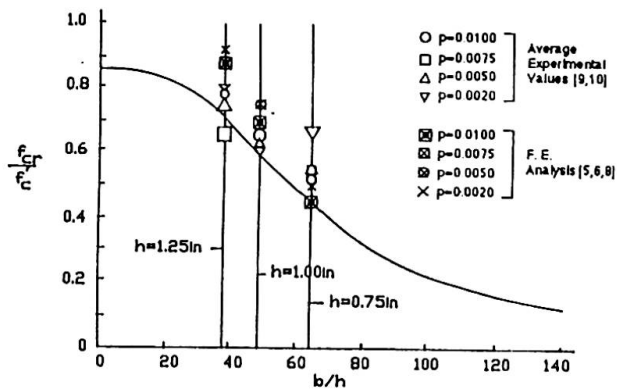

FIG. 6. Concrete Buckling Stress Versus Plate Thickness - Comparison of Experimental Results with F.E. Analysis (1 in = 25.4 mm)

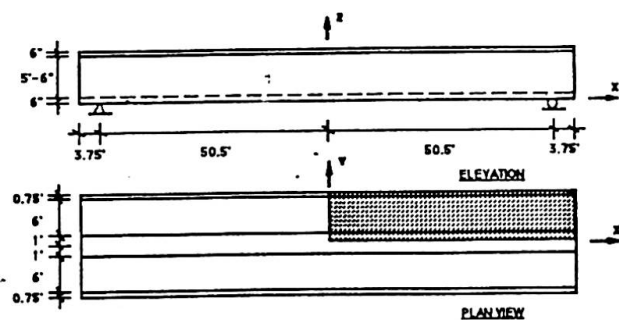

FIG. 7. Reinforced and Prestressed Concrete Folded Plate Model (1 in = 25.4 mm)

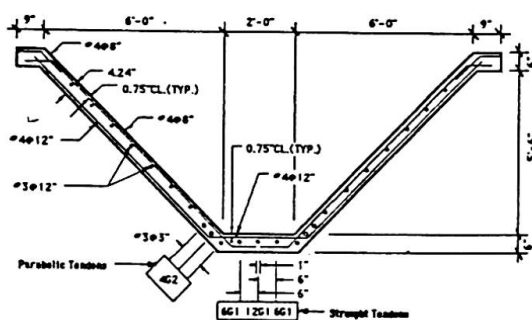

FIG. 8. Cross-Section of the Model with Reinforcements (1 in = 25.4 mm)

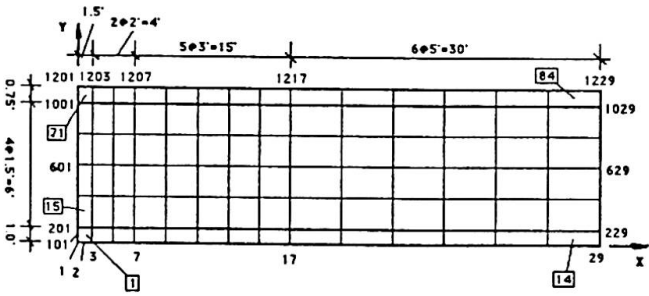
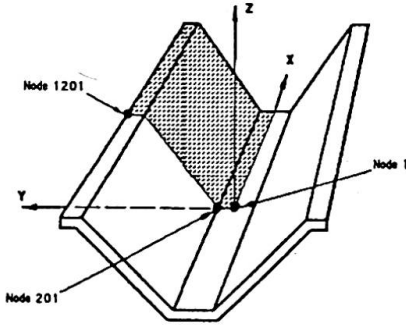

FIG. 9. Finite Element Model (1 in = 25.4 mm)

| | |
|---|--|
| Elastic Modulus | $E_c = 2.31 \times 10^6$ psi |
| Poissons Ratio | $\nu = 0.2$ |
| Uniaxial compressive yield @ zero plastic strain | $\sigma_c^y = 2320$ psi |
| Uniaxial compressive failure strength | $\sigma_c^u = 5160$ psi |
| Plastic strain at uniaxial compressive failure | $\epsilon_{11}^{pl} = 0.0025$ |
| Biaxial to uniaxial compressive strength ratio | $r_{bc}^c = 1.16$ |
| Uniaxial tension to compression strength ratio | $r_t^c = 0.075$ |
| Ratio of plastic strain in biaxial compression to uniaxial compression failure | $r_{bc}^t = 1.28$ |
| Cracking failure ratio in plane stress with one principal stress at compressive failure | $f = \sigma_{11}^t / \sigma_c^u = 0.333$ |
| Post-failure strain of tension stiffening effect | $\epsilon_t^u = 4.0 \times 10^{-4}$ |
| Shear retention factor and strain | $\rho^{tension} = 1.0$ @ $\epsilon_{max} = 0.005$ |
| Mass density | $\rho_{cm} = 1.51 \times 10^{-4}$ lb·sec ² /in ⁴ |

Note: 1 psi = 6.895 kPa; 1 lb·sec²/in⁴ = 0.1069 N·sec²/cm⁴

Table 1 Concrete Properties - Folded Plate Model

| Steel Name | Yield Stress (ksi) | Yield Strain | Ultimate Strength (ksi) | Elastic Modulus (ksi) |
|------------------------------|--------------------|--------------|-------------------------|-----------------------|
| Steel No. 1 #3 & #4 bars | 60.0 | 0.00207 | 90.0 | 29,000 |
| Steel No. 2 prestress tendon | 192.0 | 0.00662 | 240.0 | 29,000 |

Mass Density $\rho_{cm} = 7.33 \times 10^{-4}$ lb·sec²/in⁴

Note: 1 ksi = 6,895 kPa; 1 lb·sec²/in⁴ = 0.1069 N·sec²/cm⁴; 1 in = 25.4 mm

Table 2 Steel Material Properties - Folded Plate Model

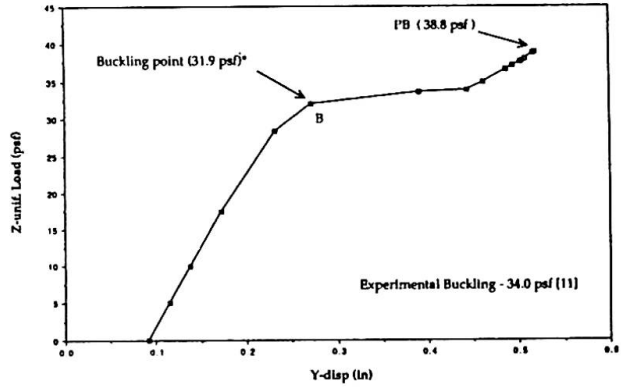

* Indicated by the negative eigenvalue generated from the system matrix which is not positive definite

Fig. 10 Deflection @ Node 1201 in Y-direction (1 psf = 47.88 Pa ; 1 in = 25.4 mm)

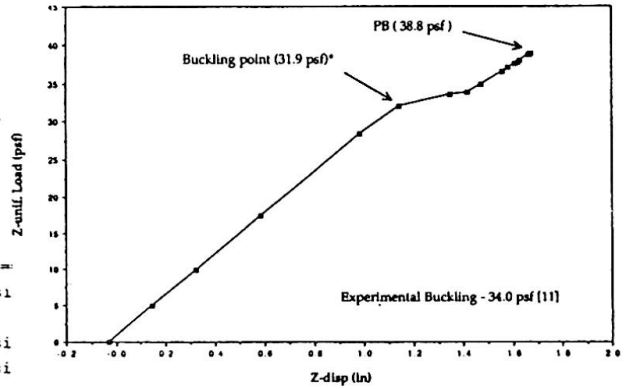

* Indicated by the negative eigenvalue generated from the system matrix which is not positive definite

Fig. 11 Deflection @ Node 1201 in Z-direction (1 psf = 47.88 Pa ; 1 in = 25.4 mm)

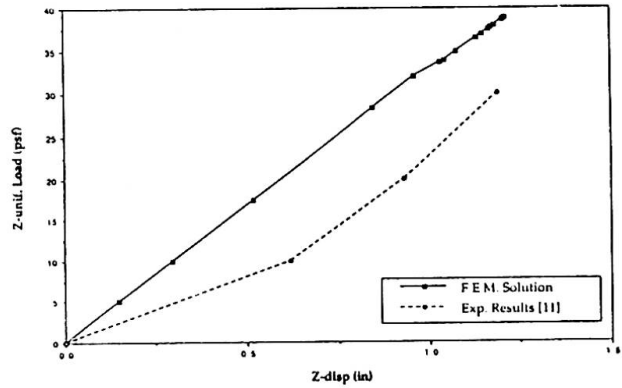

Fig. 12 Deflection @ Node 1 in Z-direction (1 in = 25.4 mm ; 1 psf = 47.88 Pa)

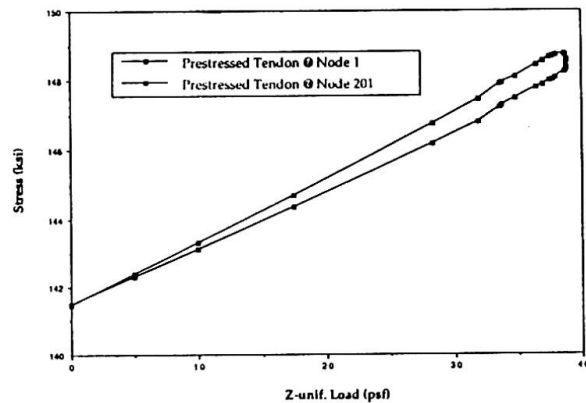

Fig. 13 Stress of Tendon in X-direction (1 ksi = 6,895.0 kPa ; 1 psf = 47.88 Pa)



5. CONCLUSIONS

(1) Local buckling may take place in very deep and slender box girder sections under the action of various load combinations, smaller in magnitude than those methods which do not consider buckling.

(2) The experimental buckling load for the folded plate model [11] is equal to 34.0 psf which is in fact the post-buckling load and it fits exceptionally well between the numerical buckling load of 31.9 psf and the numerical post-buckling load of 38.8 psf obtained from the F.E. method.

(3) Nonlinear F.E. analysis method involving elasto-plastic associated flow isotropic hardening constitutive relations for concrete and rebar treated as elastic-plastic metal can successfully predict the buckling load and the post-buckling strength of R.C. plate elements, folded plate structures and other R.C. structures.

6. ACKNOWLEDGMENT

The research described herein was supported by the National Science Foundation Grant MSM-8919385 to Tulane University, New Orleans, Louisiana. This support is gratefully acknowledged.

REFERENCES

1. CHEN, A.C.T. and CHEN, W.F., Constitutive Relations of Concrete. J. Engrg. Mech. Div., ASCE, 101 (4), August 1975. pp. 465-481.
2. CHEN, A.C.T. and CHEN, W.F., Constitutive Equations and Punch-Indentation of Concrete. J. Engrg. Mech. Div., ASCE 101, December 1975, pp. 889-906.
3. ABAQUS Manuals, Vol. 1: User's Manual, Vol. 2: Theory Manual, Vol. 3: Example Problems Manual, Vol. 4: System Manual, Version 4.8, Habbitt, Karlsson and Sorensen, Inc., Providence R.I., 1989.
4. HILLEBORG, A.M.M., and PETERSON, P.E., Analysis of Crack Formation and Crack Growth in Concrete by Means of Fracture Mechanics and Finite Elements. Cement and Concrete Research, 6, 1976, pp. 773-782.
5. DAS, S.C., Local Buckling of Concrete Box Girder Plate Elements. Presented at the TRB Comm. A2C03, Concrete Bridge Meeting, Washington, D.C., January 14, 1991, pp. 1-45.
6. DAS, S.C., HUANG, T.D. and ZHANG, X., Numerical Buckling Analysis of Concrete Plate Elements and Comparison with that of Experimental Results. Report No. ST-91-1, submitted to the NSF, part of the NSF project MSM-8919385, March 15, 1991.
7. DAS, S.C., HUANG, T.D., and ZHANG, X., Nonlinear Finite Element Buckling Analysis of a Long-Span R.C. Folded Plate Model. Report No. ST-91-2, Submitted to the NSF, part of the NSF Project MSM-8919385, April 17, 1991.
8. DAS, S.C., HUANG, T.D., and ZHANG, X., Buckling Analysis of Ultra Deep R.C. Box Girders Bridges. International Conference on New Dimensions in Bridges & Flyovers, June 27-28, 1991, pp. 85-92.
9. SWARTZ, S.E., ROSEBRAUGH, V.H. and et al., Buckling tests on Rectangular Concrete Panels. J. of the ACI, 71 (1), 1974, pp. 33-39.
10. SWARTZ, S.E., ROSEBRAUGH, V.H., Buckling of Reinforced Concrete Plates. J. of the Struct. Div., ASCE, 100 (1), 1974, pp. 195-208.
11. MARTIN, I., Full Scale Load Test of a Prestressed Folded Plate Unit. J. of the ACI, December 1971, pp. 937-944.