

Zeitschrift: IABSE congress report = Rapport du congrès AIPC = IVBH
Kongressbericht

Band: 14 (1992)

Artikel: A decision system for bridge management

Autor: Brito, Jorge de / Branco, Fernando A.

DOI: <https://doi.org/10.5169/seals-853231>

Nutzungsbedingungen

Die ETH-Bibliothek ist die Anbieterin der digitalisierten Zeitschriften. Sie besitzt keine Urheberrechte an den Zeitschriften und ist nicht verantwortlich für deren Inhalte. Die Rechte liegen in der Regel bei den Herausgebern beziehungsweise den externen Rechteinhabern. [Siehe Rechtliche Hinweise.](#)

Conditions d'utilisation

L'ETH Library est le fournisseur des revues numérisées. Elle ne détient aucun droit d'auteur sur les revues et n'est pas responsable de leur contenu. En règle générale, les droits sont détenus par les éditeurs ou les détenteurs de droits externes. [Voir Informations légales.](#)

Terms of use

The ETH Library is the provider of the digitised journals. It does not own any copyrights to the journals and is not responsible for their content. The rights usually lie with the publishers or the external rights holders. [See Legal notice.](#)

Download PDF: 13.02.2025

ETH-Bibliothek Zürich, E-Periodica, <https://www.e-periodica.ch>

A Decision System for Bridge Management

Un système de décision pour la gestion des ponts

Ein Entscheidungssystem für Wartung von Stahlbetonbrücken

Jorge DE BRITO
Research Assistant
Tech. Univ. Lisbon
Lisboa, Portugal

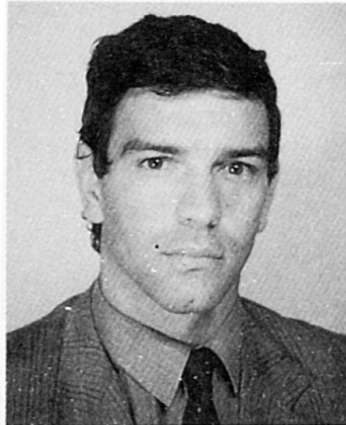

J. de Brito, born in 1959 graduated in Civil Engineering and got his MASc. degree at IST - Tech. Univ. of Lisbon, where he is presently developing his PhD. thesis, as research assistant. His research work deals with deterioration, rehabilitation and management of concrete structures.

Fernando A. BRANCO
Associate Professor
Tech. Univ. Lisbon
Lisboa, Portugal



F.A. Branco, born in 1953, is MASc. from Univ. of Waterloo, Canada, and PhD. from Tech. Univ. of Lisbon, where he is Associate Professor. Presently he is director of CMEST - Univ. Structures Research Center, and national representative at RILEM and PCSA. His research and consultant activities deal mainly with bridge and special structure studies.

SUMMARY

In this paper, a decision system for bridge management is presented. It considers data field information obtained from three levels of inspection: current inspection, detailed inspection and structural assessment. Based on this information, the decision system rates the different solutions in order to obtain the best action to take within a maintenance system or a repair/upgrading system.

RÉSUMÉ

Dans cet article on présente un système de décision pour la gestion des ponts. On considère l'information in situ qui provient de trois niveaux d'inspection: inspection courante, inspection détaillée et évaluation structurale. Avec cette information, le système de décision classifie les différents solutions pour l'obtention de la meilleure action à mener, en tenant compte des aspects de manutention ou de réparation/amélioration.

ZUSAMMENFASSUNG

Der Artikel beschreibt ein Entscheidungssystem für die Wartung von Stahlbetonbrücken. Drei überwachungsstufen liefern die entsprechend notwendige Information: gewöhnliche Überwachung, ausführliche Inspektion und Analyse der Struktur. Die so gewonnenen Daten werden von dem Entscheidungssystem benutzt, um unter den Gesichtspunkten der Wartung, Instandsetzung und Verbesserung des Bauwerks das beste Vorgehen zu wählen.



1. INTRODUCTION •

Throughout the XX century, reinforced and prestressed concrete has been the most widely used material in construction. Contrary to other materials, concrete does not benefit from a very large experience what led to a precocious reduction in the service life of some concrete bridges. This usually occurred due to an unpredicted evolution of the materials degradation, deficient design construction methods or dramatic increase of the traffic volume / loads.

The disruption of each particular bridge has very high costs for the society. It stops traffic going over it and forces thousands of users to use alternative routes at extra cost and time. Social costs due to the interruption of communications are also to be expected from such a situation. Finally, the costs of rehabilitating a disrupted bridge can be prohibitive, much bigger than the costs of building a stronger and larger structure from the very beginning.

The importance of bridge maintenance versus new bridge construction has arisen in the last decades, due to high deterioration rates that have been observed in these structures. Budgets both for building new bridges and keeping the existing ones are always limited. This means that usually, only a selection of the problems detected can be dealt with. To be aware of the existent problems and to help with rational maintenance decisions, bridge management systems have been developed and are being implemented all over the world.

In this paper, a decision system for concrete bridges management is presented. It considers data field information obtained from three levels of inspection: current inspection, detailed inspection and structural assessment. Based on this information the importance of the anomalies is rated for the current maintenance system. An economical analysis is presented for the decisions within the repair / upgrading system.

2. THE INSPECTION PROCEDURE

Within a management system, all the information must be obtained from field inspections that make the inspection sub-system. This information is kept in a data base which is the basis of any future decision procedures. The inspection procedures must be thought on a frame of bridges level and not on a single bridge level, to optimize people and equipment displacements. Inspection procedures usually consist of: current inspections, detailed inspections and structural assessments.

The current inspections are based almost exclusively in direct visual observation which seems to be the most promising diagnosis method. No main structural defects are expected to be found and only maintenance work is to result from the inspections. The recommended period of inspection is 15 months, to allow for the influence of the seasons of the year .

In the detailed inspections, besides direct visual observation, non-destructive in-situ tests of easy performance are to be used to investigate potential sources of problems. Should any main structural anomaly be detected, a structural assessment is to be recommended but not performed right away as these inspections are within the scope of general maintenance. The recommended period for this inspection is around 5 years.

A structural assessment is usually the result of the discovery of a main structural deficiency. It may also be deemed necessary should the options of strengthening or widening the deck need to be weighted. The expected results of this inspection are: the characterization of the structural anomalies, an estimation of the remaining life of the bridge and an estimation of its residual strength. All in-situ diagnosis methods and load and dynamic tests can be used, even though a careful limitation of costs should be taken into account.

3. THE MAINTENANCE SYSTEM

Within the management system, maintenance considers the activities related to the repair of small anomalies in order to maintain the bridge service level. The decisions are taken based on a rating of



anomalies according to three main points: rehabilitation urgency, structural importance and affected traffic. This rating procedure considers the results of the inspections, with a list of about 90 anomalies divided into the following groups [1]:

- | | |
|--|-------------------------------------|
| A - Superstructure global behaviour | F - Joints |
| B - Foundations / Abutments | G - Coating / Watertightness |
| C - Concrete elements | H - Water drainage |
| D - Reinforcement / Cables | I - Secondary elements |
| E - Bearings | |

For concrete bridges, the anomalies are then classified according to [1] [2]:

Urgency of Rehabilitation

- 0** - immediate action required
- 1** - short-term action required (up to a maximum of 6 months)
- 2** - medium-term action required (usually up to a maximum of 12 to 15)
- 3** - long-term action required (in the next inspection)

Importance to the Structure's Stability

- A** - anomaly of eminently structural characteristics, associated with main structural elements (deck, beams, columns, abutments and foundations)
- B** - anomaly of semi-structural characteristics associated with main structural elements or structural anomaly associated with secondary structural elements.
- C** - anomaly of semi-structural characteristics associated with secondary structural elements, anomaly of non-structural characteristics or in non-structural elements

Volume of Traffic Affected by the Anomaly

- $\alpha - t.v. \times d.l. \times k \geq n_1$ [number of vehicles km / day]
 - $\beta - n_1 > t.v. \times d.l. \times k \geq n_2$ [number of vehicles km / day]
 - $\gamma - t.v. \times d.l. \times k < n_2$ [number of vehicles km / day]
- t.v. - average daily traffic volume
d.l. - detour length
k - coefficient of traffic obstruction
n₁ , n₂ - fixed parameters (given by the bridge authorities)

Each anomaly classification-type is then included in one of the priority of action groups:

- 1 - maximum priority** g.n.p. ≥ 95
- 2 - high priority** $80 \leq \text{g.n.p.} \leq 90$
- 3 - medium priority** $70 \leq \text{g.n.p.} \leq 75$
- 4 - low priority** $50 \leq \text{g.n.p.} \leq 65$
- 5 - minimum priority** $30 \leq \text{g.n.p.}$

The classification of the anomalies is done with the following table:

	CLASSIFICATION	POINTS
URGENCY OF REHABILITATION	0	30
	1	25
	2	15
	3	5
IMPORTANCE TO THE STRUCTURE'S STABILITY	A	40
	B	25
	C	15
VOLUME OF TRAFFIC AFFECTED BY THE ANOMALY	α	30
	β	20
	γ	10



For the maintenance procedures one must act first upon the bridge that has the anomaly with the highest global number of points given; all maintenance work in the same bridge concerning every anomaly of the same type (even if with a smaller number of points) and every anomaly that the management authorities feel can be economically repaired with the same equipment and workmanship should be done.

4. THE REPAIR / UPGRADING SYSTEM

Within the management system, this module considers the important repair works. For decision making, it rates the repair work from an economical point of view, based on a present cost analysis for each option (strengthening, deck widening or bridge replacement).

4.1 The Cost Function

Building a bridge should be looked at as just another form of investment. An initial cost is paid to design and build it, there are in service costs to maintain and repair it and, when its use no more justifies its existence, it is replaced. During its life cycle, the bridge must give benefits valued higher than the sum of all the costs referred above.

For these reasons, for decision making, it is necessary to be able to quantify the global costs of building, using and replacing a bridge and to predict its benefits during its life cycle. In this work, the following cost function was adopted for the Global Costs C [3]:

$$C = C_0 + C_I + C_M + C_R + C_F - B$$

C_0	- initial costs	C_I	- inspection costs
C_M	- maintenance costs	C_R	- repair costs
C_F	- failure costs	B	- benefits

Initial costs are the costs involved in designing and building the bridge and include: preliminary studies, structural and traffic design, building the bridge and its approaches and load testing before use. The initial costs can be divided in: design costs (C_{0D}), construction costs (C_{0C}) and testing costs (C_{0T}). They can be predicted based on current construction costs, the expected structural type and the bridge deck area and using common sense percentages to partition the costs.

$$C_0 = C_{0D} + C_{0C} + C_{0T}$$

Inspection costs are the ones involved in inspecting regularly the bridge within the maintenance framework, i. e. do not include structural assessments when a main structural deficiency is suspected. The inspection costs of using a bridge can be divided in: labour costs (C_{IL}) and equipment costs (C_{IE}). They can be estimated based on the bridge dimensions, the authorities current costs and an expected calendar of inspections. It is also possible to rely on past experience in the inspection of the bridge and use linear regression techniques.

$$C_I = C_{IL} + C_{IE}$$

Maintenance costs are the ones involved in keeping the bridge in shape and exclude any main structural work. They are approximately predicted by a percentage x' of the construction costs of the bridge C_{0C} :

$$C_M / \text{year} = x' \% C_{0C}$$

This percentage can vary with the bridge's age. It is also possible to predict these costs knowing the bridge dimensions and the current maintenance costs or using linear regression techniques based on the latest years' experience.

Repair costs are the ones involved in doing main structural work (repair, strengthening, deck widening) and include the repair costs themselves and all the costs of any necessary structural assessment. The repair costs along the service life of a bridge can be divided in: structural assessment costs (C_{RSA}) and structural repair costs (C_{RSR}). They can be approximately estimated considering average repair costs for each type of repair. In the long-term, they can be roughly predicted using a percentage of the construction costs for each year that tends to grow with the bridge's age.

$$C_R = C_{RSA} + C_{RSR}$$

Failure costs are associated with the situations in which the bridge does not fully comply with what is expected of her, i. e. its design functionality. The failure costs of a bridge partially or totally impaired in its function can be divided in: structural failure costs (C_{FSF}) and functional failure costs (C_{FFF}).

$$C_F = C_{FSF} + C_{FFF}$$

The structural failure costs include all the costs resulting from a structural collapse of the bridge (or a situation in which such collapse is eminent and the bridge has to be closed to traffic). The cost associated with the structural failure can then be obtained from the probability of failure P_f and the cost of collapse C_{FF} (even though collapse does not occur under normal circumstances, these costs can still be considered in an economic analysis as insurance costs):

$$C_{FSF} = P_f C_{FF}$$

The cost of collapse can be divided in: bridge replacement costs (C_{FFR}), loss of lives and equipment costs (C_{FFL}) and architectural / cultural / historical costs (C_{FFH}).

$$C_{FF} = C_{FFR} + C_{FFL} + C_{FFH}$$

The functional failure costs C_{FFF} include all the value attributed to the fact that not all the predicted design traffic can use the bridge (or that its design speed has to be reduced during certain periods of the day or of the existence of an anomaly). The costs of detouring that fraction of traffic and the consequences (delays) caused in the bridges nearby must also be taken into account. This value can be measured in several ways:

- delay in crossing the bridge times volume of traffic delayed (C_{FFD}) (Fig.1);
- volume of traffic unable to use the bridge and having to use a detour (this inability can be caused by two reasons: the bridge not being wide enough for the amount of traffic waiting to cross it (C_{FFV}); the bridge not having the structural capability to be used by a certain margin of heavy traffic (C_{FFL})).

$$C_{FFF} = C_{FFFD} + C_{FFFV} + C_{FFFL}$$

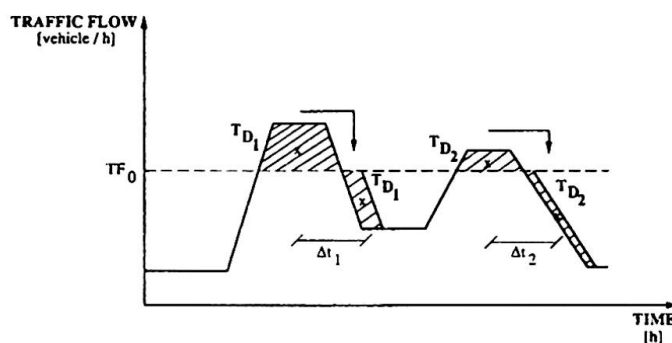

Fig. 1 Simplification proposed for the traffic flow curve versus time of the day



The prediction of such costs relies on traffic surveys (yearly and daily) and future estimates. It is also dependent on the existing alternatives to the bridge being analyzed, its traffic capacity and structural resistance.

Benefits, on the other hand, is what it would be worth to enhance the bridge in order of it to provide a better service (or be of a wider utility) than the one provided at a certain standard situation (usually the design stage). This notion can also be used to compare two solutions of repair, strengthening, deck widening or replacing of a certain bridge (in such a situation, one of the options is considered the standard situation with a benefit nil and the other is evaluated against it). A benefit is equivalent to a negative functional failure cost. This value is, of course, measured in the same way as the cost value.

4.2 The Decision Index

The cost function is the basis of the main decisions to consider when an important anomaly that impairs the functionability of the bridge is found. In these situations the possibility of upgrading (widening or strengthening) or replacing the bridge must be considered.

At the beginning of each year, the budget given to the bridge authorities for the works that go beyond maintenance is known and it must be allocated to each bridge. Decisions must be then made according to the cost effectiveness index (CEI) of each option [4]. The CEI indicates how well the proposed workplan actions compare to the no-action option. A CEI value greater than one indicates that the proposed actions are economically better than the no-action option. For each option the CEI may be quantified by:

$$CEI = \frac{(CR + CF - B) \text{ REPAIR}}{(CR + CF - B) \text{ NO REPAIR}}$$

CR - Repair Costs CF - Failure Costs B - Benefits

The CEI coefficient may be used at different levels of action, namely:

- Level 1 - To compare different solutions for the repair of the same anomaly
- Level 2 - To obtain the priority of action among the repair of different anomalies within a bridge. The maximum CEI of each anomaly is considered for comparison between different anomalies.
- Level 3 - To obtain the priority of action among the bridges of a network. The accumulated maximum CEI's of each group of repairs within each bridge are considered to compare different bridges.

5. CONCLUSIONS

Budgets both for building new bridges and keeping the existing ones are always limited. This means that only a selection of the problems detected can be dealt with, leaving the less important ones as they are. Based on inspection data, a rating of anomalies is presented to optimize maintenance procedures. When repair / upgrading / substitution is considered, the decision is taken with a rating of the deteriorated bridges, based on a cost analysis index.

6. REFERENCES

1. BRITO J.; BRANCO F., Concrete Bridges Anomalies Classification System, Proc. II Portuguese Conf. of Structural Engineering, Lisbon, 1990.
2. BRANCO F.; BRITO J., Concrete Bridges Maintenance System - Inspection Techniques and a Rating System, Proc. Int. Conf. on Bridges, Tehran, 1990.
3. BRANCO F.; BRITO J., Bridge Management Systems, Civ. Engin. European Course on Maintenance, Repair and Rehabilitation of Concrete Structures, Lisbon, 1991.
4. AYLON M., The Comprehensive Management of a Bridge Population - A Case Study, Developments in Short and Medium Span Bridge Engineering'90, Toronto, 1990.