

# Development of containment structures in India

Autor(en): **Alimchandani, C.R. / Joglekar, S.G. / Kulkarni, N.N.**

Objektyp: **Article**

Zeitschrift: **IABSE congress report = Rapport du congrès AIPC = IVBH  
Kongressbericht**

Band (Jahr): **14 (1992)**

PDF erstellt am: **23.07.2024**

Persistenter Link: <https://doi.org/10.5169/seals-853177>

## **Nutzungsbedingungen**

Die ETH-Bibliothek ist Anbieterin der digitalisierten Zeitschriften. Sie besitzt keine Urheberrechte an den Inhalten der Zeitschriften. Die Rechte liegen in der Regel bei den Herausgebern.

Die auf der Plattform e-periodica veröffentlichten Dokumente stehen für nicht-kommerzielle Zwecke in Lehre und Forschung sowie für die private Nutzung frei zur Verfügung. Einzelne Dateien oder Ausdrucke aus diesem Angebot können zusammen mit diesen Nutzungsbedingungen und den korrekten Herkunftsbezeichnungen weitergegeben werden.

Das Veröffentlichen von Bildern in Print- und Online-Publikationen ist nur mit vorheriger Genehmigung der Rechteinhaber erlaubt. Die systematische Speicherung von Teilen des elektronischen Angebots auf anderen Servern bedarf ebenfalls des schriftlichen Einverständnisses der Rechteinhaber.

## **Haftungsausschluss**

Alle Angaben erfolgen ohne Gewähr für Vollständigkeit oder Richtigkeit. Es wird keine Haftung übernommen für Schäden durch die Verwendung von Informationen aus diesem Online-Angebot oder durch das Fehlen von Informationen. Dies gilt auch für Inhalte Dritter, die über dieses Angebot zugänglich sind.

## Development of Containment Structures in India

Développement des structures de confinement en Inde

Entwicklung des Containmentbaus in Indien

### **C.R. ALIMCHANDANI**

Chairman & Man. Dir  
STUP Consult. Ltd.  
Bombay, India



### **S.G. JOGLEKAR**

Princ. Consult.  
STUP Consult. Ltd  
Bombay, India



### **N.N. KULKARNI**

Reg. Proj. Dir & Advisor  
Nuclear Power Corp.  
Bombay, India



### **M.M. TILAK**

Chief Engineer  
Nuclear Power Corp.  
Bombay, India.

### **SUMMARY**

Starting with the introduction of prestressed concrete for the containment structures in 1963, and the concept of double containment in 1967, Indian Containment Designs continued to incorporate many innovative ideas also developing the Indian prestressing industry in this process. These developments are traced in this article.

### **RÉSUMÉ**

Après avoir introduit en 1963 le béton précontraint pour les structures de confinement et en 1967 le concept du double confinement, les projets de confinement pratiqués en Inde se sont sans cesse enrichis d'idées innovatrices, permettant ainsi le développement de l'industrie indienne de la précontrainte. Cet article retrace les progrès successifs de ce secteur de la construction.

### **ZUSAMMENFASSUNG**

Seit der Einführung von Spannbeton für den Containmentbau 1963, und des Konzepts des Doppel-Containments 1967 hat "Indian Containment Designs" fortgeföhren viele Neuerungsideoen aufzugreifen, indem die indische Vorpännindustrie auf diese Weise entwickelt wird. Diese Entwicklungen sind im Artikel skizziert.



## 1. EARLY OPTION FOR NUCLEAR POWER

After becoming independent in 1947, India launched itself on a programme of planned development whose objective was the creation of economic emancipation of its poverty afflicted millions and the creation of a technologically advanced and self-reliant society. Availability of assured and cheap Energy sources was of vital importance. While taking stock of its own natural resources it became abundantly clear to the Indian planners that the most viable long term solution to energy needs can be provided only by the atomic energy and for development of this resource, self-reliance and co-operation with like minded international community was the only path. With this aim the Indian Nuclear Power Projects programme was launched with active co-operation between the newly established Dept. of Atomic Energy (DAE) and the Canadian Government. Thus in 1963, India's second 2 x 235 MWe power project was taken up for construction at Rajasthan (RAPP-1 & 2) with Canadian design Using Pressurised Heavy Water (PHWR) System.

## 2. CONTAINMENT OF RAPP - 1 & 2

It was also the beginning of the awareness of safety aspects. The concept of containing the radioactive by-products not only during the normal operations but also in the extremely unlikely event of accidental release of the same from power reactors by providing the suitable containment building became an established safety measure. The Canadian design of 235 MWe containment consisted of 1.2 m thick, 40 m I.D. R.C.C. cylindrical enclosure capped by a hemispherical dome in structural steel. In addition a cylindrical R.C.C. wall of 30 cm thickness was required to be constructed around the dome to provide radiation shielding (Ref. fig.1).

The DAE engineers, however, considered that the construction of steel dome was costly and not suitable for using local resources since it involved shipping from Canada pre-bent plates of 50 mm thickness and field welding the same followed by testing with radiography. A search was made for an alternative solution. By then, two containments of experimental reactors had been constructed in France using prestressed concrete. The know-how of French experts was available through their Indian associates. The DAE engineers took a far sighted decision to use the prestressed concrete dome to replace both the steel dome and concrete shielding, thereby reducing the cost and using fully indigenous construction technology. India thus became the second country in the world to use prestressed concrete for the containments.

The success of this joint venture paved the way for future applications and developments which ran in parallel and at times ahead of those taking place

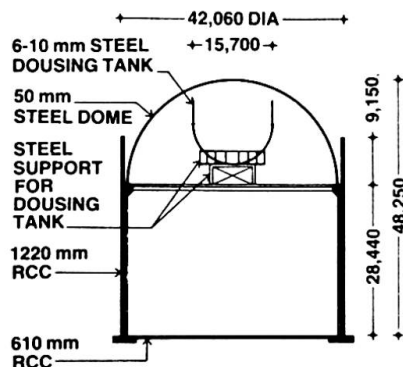

**Fig.1** RAPP Dome - Original proposal in Steel

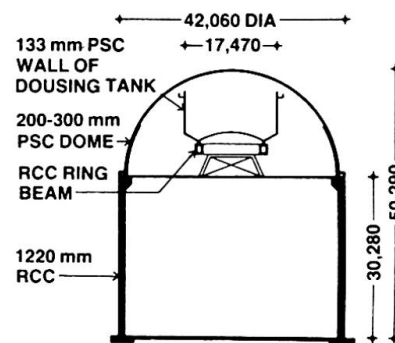

**Fig.2** RAPP Dome - As-built-in P.S.C.



elsewhere introducing in this process many innovative design concepts. The prestressing industry in India, which was only a decade old, also got impetus to develop and manufacture in the country the advanced prestressing systems of larger and larger capacities as the demand from the containment designers grew.

The original RAPP dome as conceived and as finally constructed are illustrated in fig. 1 & 2 respectively. The hemispherical dome is prestressed using meridional and ring cables upto an angle of 27.5 Deg. and by an orthogonal grid for portion above this. The meridional cables also anchor the dome to the R.C. Wall. This project used 12 dia. 7mm wire system of Freyssinet.

### 3. MADRAS ATOMIC POWER PROJECT (MAPP)

#### 3.1 Introduction of Double Containment Philosophy

Three years later for the next project at MAPP many changes in the ancillary systems of the reactor were made in the process of indigenisation of the technology. The dousing tank of RAPP was replaced by the pressure suppression pool at the bottom. This changed the shape and volume of the containment resulting in higher pressures and temperatures as compared to RAPP. Also at the time of starting the construction a policy decision was taken not to put full reliance on the cooling effect of suppression pool and to design the containment for even higher pressures and temperature effects on the basis of "dry-containment". The design pressure of MAPP Containment was taken as 1.44 kg/sq.cm. gauge as compared to 0.7 kg/sq.cm. of RAPP. At the same time, with the satisfactory experience of RAPP dome, the entire containment including the cylindrical wall and dome were decided to be constructed using prestressed concrete. Structurally, a 610 cms. thickness of wall was adequate for resisting the design loads. However, for providing full shielding from radioactivity increased thickness of material was needed. An ingenious solution was developed introducing in this process for the first time the concept of double containment which was to develop further in future containments (fig.3). A masonry wall constructed in reinforced random rubble masonry (fig.4) with thickness of 710 mm was proposed as a second wall surrounding the prestressed concrete wall, leaving an annular gap of 1000 mm. The masonry wall is designed to perform many functions. Apart from providing radiation shielding to the exterior it provides a weather shield to the inner P.S.C. Wall and also protects the same from impact of external missiles. In addition it created the annular volume into which the leakage from the inner P.S.C. Containment could be trapped. Provisions were made in the design to start pumping of the contaminated radioactive air from the annulus and filtering the same through scrubbers before releasing the same to atmosphere through specially built stack. Since in this operation of creating a small vacuum in the annulus the

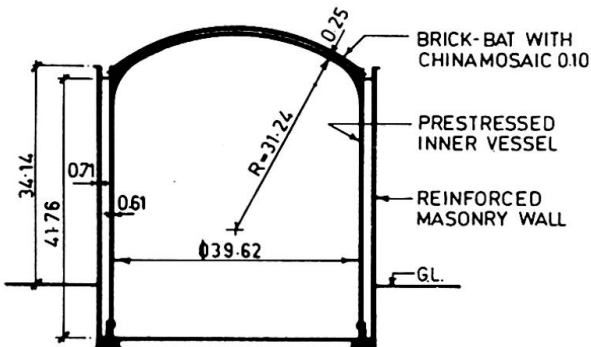

Fig.3 Double Containment of MAPP

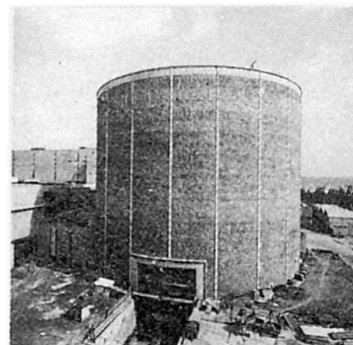

Fig.4 MAPP - Masonry Wall & B.O.P. opening.



net flow of air through the masonry wall is from outside to inside, the system presented a theoretically zero net-radioactive-leakage through the containment. This was perhaps the most significant contribution of MAPP to the containment design philosophy.

### 3.2 Requirement of Large Break-out-Panel

Additional demands were made by the developing reactor technology on the ingenuity of the civil designs in specifying the requirement of large re-openable rectangular 'Break-Out-Panel' of the size of 10m x 8 m. This was an additional requirement over and above the air lock entry of 3.2 m x 3.0 m size normally needed for the operational reasons. The normally adopted solution of providing openable steel hatch would have required massive local thickening and reinforcement and would have superimposed predominantly bending effects on the cylindrical shell structure otherwise ideally suitable as a prestressed concrete pressure vessel. To avoid this problem a section of the cylindrical wall of the 10 m x 8 m size was designed as an independent panel which is not cast monolithically with the rest of the cylinder but made structurally an integral part of the same by establishing at the boundaries of the panel the same state of membrane stresses as existing in the surrounding wall portion. Flat jacks placed within the thickness of the wall were used to create this balanced state of stresses. The horizontal ring cables and vertical cables were re-threaded passing through this portion as if the cut did not exist. This system avoided all local bending effects enabling the cylinder to behave as a shell structure. This panel can be re-opened by removing the prestressing cables and the flat jacks. For full details of this scheme reference is made to Vol. 1 of FIP Congress of 1986.

### 3.3 Provision of Rock Anchors

With good massive and impervious rock available as foundation strata, the PSC Wall was resting on a nominally thick RCC annular ring foundation. The weight of the wall and the dome is not adequate to resist the uplift caused by the pressure for which purpose flexible prestressed rock anchors have been used.

For one of the two reactor buildings the foundation rock presented unforeseen problems in certain zones and the system of rock anchors had to be replaced with massive ring raft foundation anchoring the containment wall to the same and making use of the mass of the ring raft for resisting uplift.

This project uses 12 dia 8mm wire system of prestressing manufactured indigenously by Freyssinet.

## 4. NARORA ATOMIC POWER PROJECT (NAPP) AND KAKRAPAR PROJECT

The next project at Narora is located on bank of river Ganges in north India with foundations on alluvial sandy strata requiring a full RCC raft as a common foundation for the containment and the internal building. Also this site is located in the zone of high seismicity where the S.S.E. Earthquake of 0.3 g ground acceleration was considered for the design.

Further changes in the internal ancillary systems were made changing the shape of the containment for this series of projects. The main steam generators were brought partially out of the inner containment and placed on the containment slab. The main idea was to keep only the primary heat exchange circuits involving radioactive inventory inside the containment and to bring out the secondary steam circuits outside. The arrangement is shown in fig. 5.

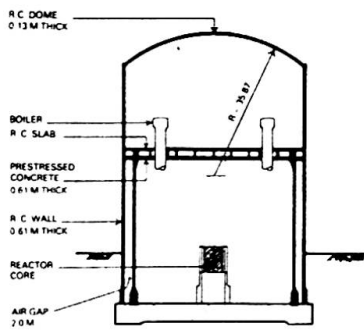

Fig.5 NAPP Containment

This unusual arrangement put the following unusual demands on the design of the containment slab.

- Spanning over 40 m on containment wall the slab had to carry the enormous accident pressure of 14.4 t/sq.m. in bending unlike the spherical dome which is a naturally suited shape for resisting the pressure load by membrane action.

- The large requirement of sectional modulus combined with the need to reduce the adverse effects caused by the combination of high seismicity and large mass of the slab called for the construction of a cellular slab which has a more favourable strength to mass ratio.

- The functional requirement demanded that there should be no relative movement between the boiler and inner structure, but at the same time, containment slab should be able to deflect independently. To overcome this problem specially designed spring supports were engineered supporting boilers on the containment slab.

- The large number of embedded parts on the top slab made it impossible to put prestressing cables in any practical way in the top slab thus making RCC action mandatory for resisting upward pressures. At the same time the inner barrier (lower slab) had to be prestressed to keep it leak-tight.

A composite cellular slab with prestressed bottom slab and RCC webs and top slab was evolved. The ingenious design of this slab meeting all the above demands is described elsewhere in the documents of this congress and hence reference is made to the same for details. (Ref. Poster Session)

The concept of double containment introduced in MAPP was further refined in this design. The outer containment was provided as a complete enclosure over the inner containment unlike MAPP where dome portion does not have an out containment. The material was changed to reinforced concrete which is a more leak-tight material of universal availability unlike stone masonry which used locally available specialist skill around MAPP area. Incidentally the extra leak-tightness of RCC also reduced the load on pumps which create the vacuum in the annular space requiring smaller capacity pumps. Unlike MAPP, this system in NAPP is proposed to be kept permanently under negative pressure.

The large break-out panel of MAPP was no longer required to be of re-openable type and hence could be closed after moving in of heavy components. The location of this temporary opening called closure panel has been merged with that of the Airlock. However, the use of flat jacks to prestress the newly concreted portion of the panel and to establish the desired stress patterns in this area has been continued. Four such reactors at two sites have been constructed and tested with this design, the second site being at Kakrapar.

For this project a new Freyssinet system of Prestressing was developed and tested indigenously before acceptance. This system uses 12 nos. of 13mm strands and steel wedges similar to 'K' series anchorages of Freyssinet but using the modified S-6 jacks of their 12 T 13 system. This system has now become well established in the Indian construction scene.



## 5. RAJASTHAN 3 & 4 AND KAIGA STATIONS

The next series of 235 MWe containments at these sites look more like their western cousins used for PWR series by the French. While retaining the double containment philosophy, the standardised design has a common foundation raft for Inner and outer containment and internal building with provision of stressing gallery inside the body of the raft. The walls are constructed monolithically with the raft and have segmental domes over them. The outer containment and dome are in RCC and the inner system in PSC. The typical cross section is seen in fig.6.

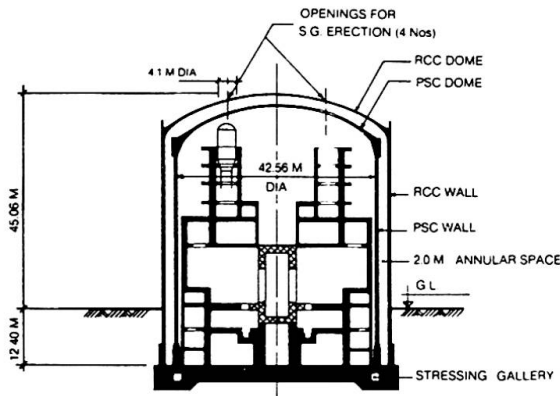

Fig.6 Section of Kaiga Containment

The requirement of large breakout panel has been completely eliminated. However, the size of Airlock has gone in for upward revision. The concept of providing openings in the inner prestressed dome for erection and subsequent removal of boilers is an extension of similar concept introduced in Kakrapar design for RCC outer dome at Kakrapar site.

For the Kaiga Site, the seismic effects are more severe causing uplift of raft of more than 60%. To avoid this, use of rock anchors has

been made. These are provided through the annular space between the inner and outer wall anchoring the raft to the base rock. For these projects, prestressing systems of larger capacity using 19 strands of 13mm indigenously manufactured and tested by DAE has to pass the acceptance tests been used. For additional details of this design reference is made to the presentation in poster session of this congress.

## 6. FUTURE DEVELOPMENTS - 500 MWe SERIES

The basic design concepts which are on the same lines as that of Kaiga & RAPP 3 & 4 have been adopted for this new generation of higher unit capacity reactors. However, the search for better, cheaper and faster solutions consistent with the stringent requirements of safety has continued. It is proposed to introduce, the systems of slipforming of walls to minimise the construction joints and to maximise the speed. This is ofcourse subject to the economic and time viability. Also it is proposed to use a fully integrated steel dome as a shuttering for PSC dome thus enabling early release of lower floors for erection of equipment.

## 7. CONCLUSION

The developments in the field of containment structures in India which started in 1963 are typical examples of the state-of-the-art in this field. Following the introduction of prestress congress the concept of double containment and many other innovative ideas have been developed while meeting difficult challenges. These structures represent one of the most successful adoption of advanced design and construction technologies of the west by a developing country using locally available skills and materials giving in this process impetus to indigenous prestressing industry.