

Zeitschrift: IABSE congress report = Rapport du congrès AIPC = IVBH
Kongressbericht

Band: 14 (1992)

Artikel: Urea silos at Hazira, Gujarat

Autor: Joglekar, S.G. / Deshpande, V.L.

DOI: <https://doi.org/10.5169/seals-853186>

Nutzungsbedingungen

Die ETH-Bibliothek ist die Anbieterin der digitalisierten Zeitschriften. Sie besitzt keine Urheberrechte an den Zeitschriften und ist nicht verantwortlich für deren Inhalte. Die Rechte liegen in der Regel bei den Herausgebern beziehungsweise den externen Rechteinhabern. [Siehe Rechtliche Hinweise.](#)

Conditions d'utilisation

L'ETH Library est le fournisseur des revues numérisées. Elle ne détient aucun droit d'auteur sur les revues et n'est pas responsable de leur contenu. En règle générale, les droits sont détenus par les éditeurs ou les détenteurs de droits externes. [Voir Informations légales.](#)

Terms of use

The ETH Library is the provider of the digitised journals. It does not own any copyrights to the journals and is not responsible for their content. The rights usually lie with the publishers or the external rights holders. [See Legal notice.](#)

Download PDF: 08.02.2025

ETH-Bibliothek Zürich, E-Periodica, <https://www.e-periodica.ch>



Urea Silos at Hazira, Gujarat

Silos à engrais, Hazira, Gujarat

Düngersiloanlage in Hazira, Gujarat

S.G. JOGLEKAR

Princ. Consult.
STUP Consultants Ltd.
Bombay, India

V.L. DESHPANDE

Joint Princ. Consult.
STUP Consultants Ltd.
Bombay, India

1.0 UREA STORAGE AND HANDLING FACILITIES

The urea handling and storage facility for the gas based fertilizer complex at Hazira, India, is one of the largest constructed in Asia. It consists of a twin horizontal silo having storage capacity of 90,000 tonnes of urea, a 9 storied transfer house structure and approx. 1000 m long conveyor galleries connecting transfer house, silos and bagging plant.

2.0 THE STORAGE SILO

The storage silo consists of twin horizontal silos 195 m x 130 m in plan, which are in the form of two intersecting inverted catenaries joined in the centre with a vertical wall, refer fig. 1. Each catenary has a span of 65.5 m at the springing level and rise of over 33 m. The catenary shape carries the gravity loads like self weight which is the main load in axial compression. The other loads such as load from loading-conveyors at top, wind, seismic and thermal induce bending effects for which the moment of resistance is developed by providing depth of 1.2 m to the folded plate units. These folded plate units having horizontal width of 3.4 m are placed next to each other in a continuous manner to cover the length of 195 m. Thus the same structural unit provides both the longitudinal and transverse spanning system. Each folded plate has inclined webs at 45 Degree which are 70 mm thick while flanges are 100 mm. Extra thickening is provided at the junction of webs and flanges in order to accommodate the main steel which is along the direction of the catenary. A number of longitudinal diaphragms have been provided to ensure the prismatic behaviour of the folded plate.

The loading conveyor at the top is supported on precast inverted portal frames which in turn are connected to the longitudinal stiffening beam connecting the folded plates.

The two end gable walls are independently standing folded plate type of units without top connections to the shell.

2.1 Foundation

Detailed soil investigation indicated a very expansive type of clay in the top layers. Space restriction precluded taking foundation below these layers. It would have also increased the span and the cost of the structure. Therefore the expansive soil was replaced by properly compacted and confined river sand and used as a foundation strata.



The twin arches are supported on the three continuous strip footings. Freyssinet hinges are introduced between the shell and all the three strip footings, which avoids secondary bending effects.

3.0 CONSTRUCTION SCHEME

Fig. 2 shows the precast units of folded plates being placed on the temporary steel arches. A unit of 24 m x 130 m of silo was thus covered by pre-cast units which are connected together by cast-in-situ high-strength concrete which permitted early decentering. The longitudinal and transverse reinforcement projecting from the pre-cast shells was field welded. Field welding of these HYSD bars was a major and tedious job requiring close supervision since the structural continuity depends on this operation. Each such unit was completed in 4 weeks. The supporting arches were then moved forward on rails for casting of next unit of 24 m length.

4.0 OTHER STRUCTURES

Transfer house which is a 9 storied structure with 5000 sq. m builtup area is of cast-in-situ construction. The 1000 m long conveyor galleries are supported on 4 column trestle units over which precast longitudinal beam and flooring and precast portal frame units covering the conveyors on all sides are erected.

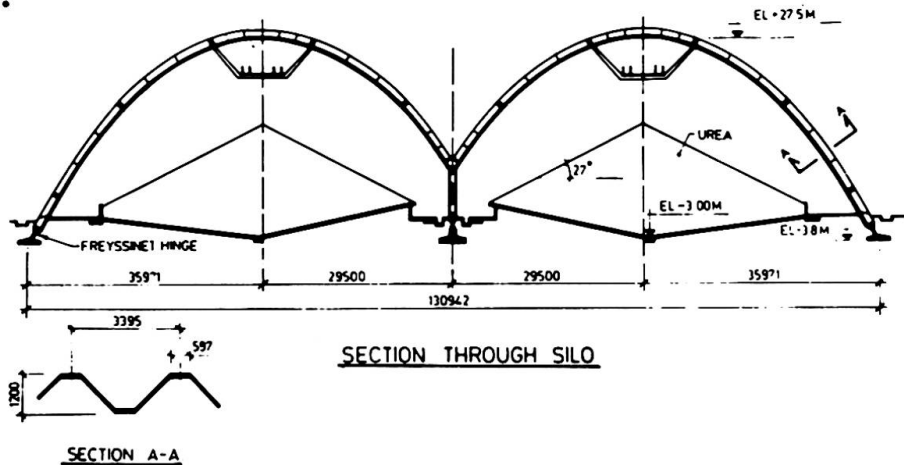

Fig.1 Section through Silo

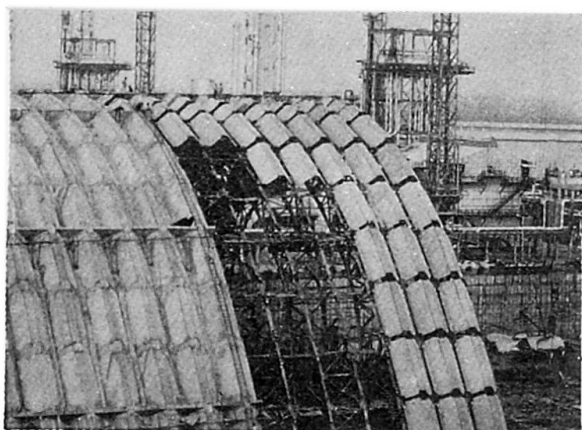

Fig.2 Preparation of a typical 24 m unit for in-situ connection

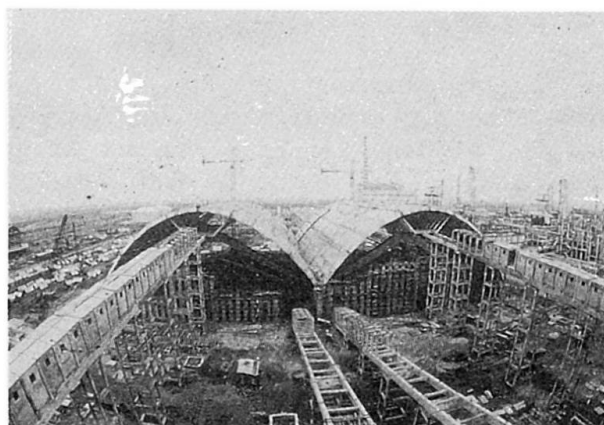

Fig.3 Silos & Conveyor Galleries