

High-grade steel in reinforced concrete

Autor(en): **Saliger, R.**

Objektyp: **Article**

Zeitschrift: **IABSE congress report = Rapport du congrès AIPC = IVBH
Kongressbericht**

Band (Jahr): **2 (1936)**

PDF erstellt am: **21.07.2024**

Persistenter Link: <https://doi.org/10.5169/seals-3165>

Nutzungsbedingungen

Die ETH-Bibliothek ist Anbieterin der digitalisierten Zeitschriften. Sie besitzt keine Urheberrechte an den Inhalten der Zeitschriften. Die Rechte liegen in der Regel bei den Herausgebern. Die auf der Plattform e-periodica veröffentlichten Dokumente stehen für nicht-kommerzielle Zwecke in Lehre und Forschung sowie für die private Nutzung frei zur Verfügung. Einzelne Dateien oder Ausdrucke aus diesem Angebot können zusammen mit diesen Nutzungsbedingungen und den korrekten Herkunftsbezeichnungen weitergegeben werden. Das Veröffentlichen von Bildern in Print- und Online-Publikationen ist nur mit vorheriger Genehmigung der Rechteinhaber erlaubt. Die systematische Speicherung von Teilen des elektronischen Angebots auf anderen Servern bedarf ebenfalls des schriftlichen Einverständnisses der Rechteinhaber.

Haftungsausschluss

Alle Angaben erfolgen ohne Gewähr für Vollständigkeit oder Richtigkeit. Es wird keine Haftung übernommen für Schäden durch die Verwendung von Informationen aus diesem Online-Angebot oder durch das Fehlen von Informationen. Dies gilt auch für Inhalte Dritter, die über dieses Angebot zugänglich sind.

IIC 3

High-Grade Steel in Reinforced Concrete.

Hochwertige Stähle im Eisenbetonbau.

Aciers à haute résistance dans le béton armé.

Dr. Ing. R. Saliger,

Professor an der Technischen Hochschule Wien.

A. Columns with high-grade steel reinforcement.

The numerous experiments that have been made with columns, reinforced by longitudinal bars and stirrups¹ have shown that it is rarely possible to use longitudinal reinforcement to its full upsetting limit. The limit of upsetting is reached only where concrete columns are laterally reinforced. The reason for this lies in the fact that upsetting to destruction in concrete does not reach the degree of upsetting which exists in the upsetting stress of the reinforcement bars. The result is that the destruction of the concrete takes place earlier and that the longitudinal bars buckle. In such columns the stress in the longitudinal reinforcement is expressed by the ratio of $E_e : E_b$, and it makes no great difference whether the longitudinal reinforcement is of mild steel or high grade steel. *The use of high-grade steel is therefore justifiable in general only for laterally bound concrete columns which can withstand a higher degree of upsetting.*

a) Experiments with laterally bound reinforced concrete columns with high-grade steel insertion.

The investigation included, apart from research work carried out on concrete encased cast iron columns, a series of experiments which were carried out between 1929 and 1933 and which have been reported on elsewhere².

The first set of experiments refers to five different designs of column construction carried out in equal sets of two, in all ten columns, which had the

¹ *Bach*: Mitteilungen über Forschungsarbeiten des V.D.I. (Communications concerning experimental work carried out by the Institution of German Engineers), Issue 29 and 166. *Saliger*: Zeitschrift für Betonbau 1915, Issue 2 to 4. *Commission du Ciment armé*, Paris 1907. *Emperger*: Versuche an Säulen aus Eisenbeton (Tests on reinforced concrete columns) 1908. *Spitzer*: Issue 3 of the Österr. Eisenbetonausschuß (Austrian Commission on Reinforced Concrete). *Mörsch*: Der Eisenbetonbau (German Commission on Reinforced Concrete) Issue 5, 10, 14, 21, 28, 34. *Probst*: Vorlesungen über Eisenbeton (Lectures on reinforced concrete) Vol. 1, Berlin 1917.

² *Beton und Eisen* 1930, Issue 1, 17. *Bauingenieur* 1931, Issue 15, 16. Österr. Eisenbetonausschuß (Austrian Commission on Reinforced Concrete) Issue 13. Bericht auf dem Internat. Kongreß für Beton und Eisenbeton in Lüttich 1930 u. a. (Report submitted to the International Congress on Concrete and Reinforced Concrete held at Liege, 1930 e.c.)

following dimensions: 1.2 m length; 16-angled section; diameter-34 cm. The concrete core section was 700 to 740 cm². Prism resistance of the concrete: 227 kg/cm²; longitudinal reinforcement was of high grade round bar steel having an average yield point of 7.35 tons/cm²; percentage of reinforcement: 4.3 to 8.8 %. Lateral reinforcement for 8 columns with steel having a yield point of 5.2 tons/cm², percentage of lateral reinforcement 0.5 to 2.0 %. Two columns had lateral bindings of iron with $\sigma_s = 2.6$ tons/cm² and a percentage of lateral reinforcement of 2.1 %.

The second lot of experiments included six various types of column structure divided into three sets of two equal columns all columns being of 1.2 m long and of octagonal cross section with a diameter of 35 cm; cross section of concrete core: 760 cm²; prism resistance: 204 kg/cm²; longitudinal reinforcement: 3.8 to 11.2 %; yield point: 7.7 tons/cm². In six of the columns the longitudinal reinforcement had been butt-welded in the centre. The lateral binding consisted of hoop iron with yield point of 2.9 tons/cm²; the percentage of lateral reinforcement for all these columns was 1.1 %.

The third set of experiments was carried out with sixteen columns having a length of 3 m. The prism strength of the concrete was 116 kg/cm². The longitudinal reinforcement for fourteen of these columns consisted of round steel bars having a yield point of 4.25 tons/cm²; in the case of two of the columns this limit was 2.77 tons/cm². The longitudinal reinforcement percentage was 3.8 to 14.8. The lateral binding for six columns was round bar steel with a yield point of 5.2 tons/cm²; for ten of the columns it was steel $\sigma_s = 2.5$ tons/cm². The lateral reinforcement percentage lay between 0.5 and 2.2 %.

Further tests were carried out with ten columns each 3 m long reinforced with rolled section having a yield point of 2.67 tons/cm², and a reinforcement percentage of 3.7 to 11.9 % (concrete encased steel columns). The concrete core sections for eight of the columns were 680, or 952 cm²; for two columns of rectangular shape the core cross-section was 490 cm². The strength of concrete was 146 kg/cm². The lateral binding had a yield point of 2.5 to 2.9 tons/cm² and the reinforcement percentage was 0.6 to 1.3 %.

The fifth set of tests was carried out with six columns having a length of 1.5 m and fourteen which were 3 m long each; the shaft was 34 cm thick and had a core area of about 760 cm². The prism strength of the concrete was 211 kg/cm². Longitudinal reinforcement of round bar steel had a yield point of $\sigma_s = 2.4$ for four of the columns, for the remaining sixteen it was $\sigma_s = 6.16$ to 6.92 tons/cm² with reinforcement percentages of 4.6 to 11.0 %. Lateral reinforcement consisted of steel of $\sigma_s = 2.0$ to 2.3 tons/cm² representing a percentage of reinforcement of 0.5 to 2.1 %.

b) Conclusions drawn from the tests and from theoretical considerations.

1) Extent of experiments.

The longitudinal reinforcement in the above experiments consisted of steel having a yield point of 2.2 to 7.7 tons/cm² and reinforcement percentages of 4 to 14 %. For lateral binding steel of 2.0 to 5.2 tons/cm² and percentages of

0.5 to approx. 2.0 % was used. The experiments thus covered the whole extent of reinforcement percentages which are actually used in practice.

2) *Full utilisation of longitudinal reinforcement.*

The rupture point upsetting strength of the laterally reinforced concrete columns generally exceeds the compressibility of the non-reinforced concrete very considerably. If the lateral reinforcement is adequate this compressibility will be found to be so high that it reaches the upsetting limit of the longitudinal reinforcements or the yield point fixed by definition may even be exceeded. No noticeable difference between the upsetting limit during compression tests and the yield limit of the steel during the tensile test was observed. In the case of laterally reinforced columns it is possible to utilise to the full the longitudinal reinforcements of high-grade steel. The behaviour of the concrete encased rigid steel columns is analogous to that of flexible longitudinal reinforcement. Buckling of individual bars or of the steel columns encased in concrete can be disregarded where the column is properly designed and executed. In the case of very slender columns there is some risk of buckling of the whole columns.

3) *Requisite thickness of the spiral reinforcement.*

It was possible to utilise to the full the upsetting limit of the longitudinal reinforcement in all those columns in which the amount of lateral binding was:

$$F_u \cdot \sigma_{u \text{ streck}} \geq 0.05 F_e \cdot \sigma_{\text{stauch}}$$

and if
$$F_u \cdot \sigma_{u \text{ streck}} \geq 0.1 F_k \cdot \sigma_p$$

or
$$\mu_u \geq 0.05 \mu \cdot \frac{\sigma_{\text{stauch}}}{\sigma_{u \text{ streck}}} \quad \text{and} \quad \mu_u = 0.1 \frac{\sigma_p}{\sigma_{u \text{ streck}}}$$
 ³

in the above formula σ_p represents the prism strength of the concrete. F_u = lateral binding, F_e = longitudinal reinforcement, streck = yield limit, stauch = upsetting.

Where the amount of lateral binding decreases (expressed by $F_u \sigma_{u \text{ streck}}$) below a certain figure, the upsetting limit of the longitudinal bars cannot be reached with certainty. If however the amount of lateral binding is considerably higher, then the column concrete is capable of resisting higher upsetting values and in that case the longitudinal bars are subjected to pressure which may exceed the upsetting limit as laid down by definition. Where conditions are otherwise similar, the lateral reinforcement with a high yield limit is more effective than where softer steel is used.

4) *Effects of lateral reinforcement.*

Lateral reinforcement has two objects: Increase of strength in concrete by means of circular hooping is $N_u = a \cdot F_u \sigma_{u \text{ streck}}$. If the concrete had no inherent strength and behaved like a liquid, then $N_u = \frac{1}{2} F_u \cdot \sigma_{u \text{ streck}}$, that is: $a = \frac{1}{2}$. Ex-

³ The conception according to which a considerably stronger reinforcement, for instance, of 2 to 3%, is necessary in order to ensure full utilisation of prismic strength and of the upsetting limit of longitudinal reinforcement, is not covered by these experiments. See: *Freudenthal*: Verbundstützen für hohe Lasten (Composite columns for high loading), Berlin, 1933.

periment and theory have shown that for concrete, when m is the Poisson coefficient, $a = \frac{m}{2} = 1.5$ to 4, in which case the lower value refers to high compressive stresses in high-grade concrete and the higher value to lower compressive stresses in low-grade concrete. As the quality of the concrete rises, the coefficient a expressing the effect of reinforcement decreases. As an average $a = 2$ to 3 is attainable. The effect of lateral reinforcement increases with the yield limit $\sigma_{u \text{ streck}}$ of the lateral reinforcement. The first mentioned object of lateral binding is thus based on an increase of compressive strength of the concrete by

$$\Delta \sigma_p = \frac{N_u}{F_k} = 2,5 \mu_u \sigma_{u \text{ streck}}$$

as an average. The second object of lateral reinforcement is to ensure sufficiently high deformations of the concrete, attainment of the upsetting limit of the longitudinal reinforcement, joint action of the two materials generally and finally, prevention of buckling of the longitudinal bars. Where compression is carried to the limit of inherent strength of the concrete, the stressing of the lateral binding is low, when the upsetting compression rises, the stresses in the lateral reinforcement rise rapidly up to the yield limit and even leads to fracture.

5) Formation of cracks.

Up to the point of the formation of cracks the total sectional area of the concrete (core and cover) and of the longitudinal bars act in the same way as ordinarily longitudinally reinforced concrete columns, according to the ratio of $E_c : E_b$ of specific elongation, without any marked influence due to the lateral reinforcement. The longitudinal cracks appear with such compression in concrete which is approximately equivalent to the prismic strength. The transverse elongation ε_q of the concrete and thus of the concrete cover over the bars amounts to about $\varepsilon_q = \frac{\varepsilon}{m}$.

If the capability of expansion of the concrete be taken as $\varepsilon_q = (1.5 \text{ to } 2) \cdot 10^{-4}$ and $m = 7$, the result will be $\varepsilon = 7 (1.5 \text{ to } 2) \cdot 10^{-4} \approx (1 \text{ to } 1.5) \cdot 10^{-3}$, that is, the cover may be expected to crack with a shortening of the column by about 1 to 1.5 mm per metre. For less good quality of concrete ε_q will be smaller and m will be larger and *vice-versa* for high-grade concrete, so that the upsetting of the column mentioned can be taken as an average value. A shortening of 1 to 1.5 mm per metre corresponds to a longitudinal stress in the concrete of the column of about 100 to 250 kg/cm², that is the prism strength of the concrete. After exceeding the prism strength of the concrete, the cover begins to peel off. The cracking load can be expressed thus:

$$N_{\text{Riss}} = (F_b - n \cdot F_c) \sigma_p \quad (\text{Riss} = \text{crack})$$

And thus the safety against crack formation becomes:

$$s_R = \frac{N_{\text{RiB}}}{N_{\text{zul}}} \quad \begin{array}{l} (\text{RiB} = \text{crack}) \\ (\text{zul} = \text{permissible}) \end{array}$$

When the load is increased beyond N_{Riss} the concrete cover over the bars breaks off.

6) *Limit-case.*

Encased columns, whose carrying capacity in the form of ordinarily longitudinally reinforced columns (including the cover of concrete surrounding the core) is greater than that of laterally reinforced concrete (without considering the concrete cover over the bars) fail when cracks begin to form and the cover falls off the column. The cracking load in such cases is the maximum load. As the strength of the lateral reinforcement increases and the participation of the concrete cover in the total concrete area decreases, so the breaking load exceeds the cracking load.

7) *Breaking load and permissible working load.*

In every case in which the conditions of Point 3 are complied with, the carrying capacity of the columns with high-grade steel reinforcement will be the result of the sum of resistances set up by the prism strength of the concrete core, the strength of the longitudinal reinforcement (without buckling reduction) and of the tensile strength (of the yield limit) of the reinforcement.

$$N_{\text{Bruch}} = F_k \sigma_p + F_e \sigma_{e \text{ stauch}} + 2.5 F_u \cdot \sigma_{u \text{ streck}} \quad (1)$$

with s times safety

$$N_{\text{zul}} = \frac{N_{\text{Bruch}}}{s}. \quad (\text{Bruch} = \text{failure})$$

When the load is practically static the factor of safety $s \cong 2.5$ suffices. Experience has shown that where the workmanship is good a minimum value of concrete strength in the structure can be expected to have an average value of

$$\sigma_{p \text{ min}} = \frac{2}{3} \sigma_{p \text{ mittel}}. \quad (\text{mittel} = \text{average})$$

Hence we receive:

$$N_{\text{zul}} = \frac{F_k \sigma_{p \text{ mittel}}}{3.5} + \frac{F_e \sigma_{e \text{ stauch}}}{2.5} + F_u \sigma_{u \text{ streck}} \quad (2)$$

This relation can be applied *without determination of permissible stresses* in order to calculate the permissible working load or after to a corresponding transformation to determine the dimensions on the basis of quality of the material and the safety factor. If it is wanted to calculate in the usual manner by using permissible stresses then the following formula has to be employed

$$N_{\text{zul}} = F_k \cdot \sigma_{b \text{ zul}} + F_e \cdot \sigma_{e \text{ zul}} + 2.5 F_u \cdot \sigma_{u \text{ zul}} \quad (2a)$$

By substituting:

$$\frac{\sigma_{e \text{ zul}}}{\sigma_{b \text{ zul}}} = n \quad \text{and} \quad \frac{\sigma_{u \text{ zul}}}{\sigma_{b \text{ zul}}} = n_u,$$

we receive

$$\left. \begin{aligned} N_{\text{zul}} &= (F_k + n F_e + 2.5 n_u F_u) \sigma_{b \text{ zul}} \\ &= (1 + n \mu + 2.5 n_u \mu_u) F_k \sigma_{b \text{ zul}} \end{aligned} \right\} \quad (2b)$$

8) *Participation of the concrete and the steel reinforcement in the strength.*

The participation of the steel in the carrying capacity of the structure is greater, within the zone covered by tests, in proportion as the longitudinal reinforcement and the lateral binding are stronger and in proportion as the steel is of better quality. For instance,

$$\sigma_{e \text{ stauch}} = 6000, \sigma_{u \text{ streck}} = 4000 \text{ and } \sigma_p = 200 \text{ kg/cm}^2,$$

$$n = 30 \text{ and } n_u = 20 \text{ and assuming } \mu_u = \frac{\mu}{6}$$

the values given in the numerical table will result. Here σ_b represents the increased compressive strength of the concrete resulting from the lateral rein-

$\mu = \frac{F_e}{F_k} =$	0,03	0,06	0,12
$\frac{N_b}{F_k \sigma_p} =$	1	1	1
$\frac{N_e}{F_k \sigma_p} =$	0,9	1,8	3,6
$\frac{N_u}{F_k \sigma_p} =$	0,25	0,5	1,0
$\frac{N_{Bruch}}{F_k \sigma_p} =$	2,15	3,3	5,6
$\frac{\sigma_b}{\sigma_p} =$	1,25	1,5	2,0
Participation of the concrete	47	30	18 %
" " " longitudinal bars }	42	55	64
" " " lateral binding }	11 } 53	15 } 70	18 } 82 %
$\frac{N_{Riss}}{F_k \sigma_p} =$	2,03	2,65	3,90
$\frac{N_{Riss}}{N_{Bruch}} =$	0,95	0,80	0,70
$s_R =$	2,4	2,0	1,7

forcement and as compared to the prism strength. The cracking load is calculated at $F_b = 1.4F_k$, the safety against cracking s_R with $s = 2.5$ times the safety against failure.

We can deduce from the Table that on the assumptions mentioned the average breaking stress (reduced to the area of the core) rises with a 12 per cent. longitudinal reinforcement and a 2% lateral reinforcement to $\sigma = 5.6 \sigma_p$. With a prism strength of $\sigma_p = 200$ kg an average breaking stress of $\sigma = 5.6 \cdot 200 = 1120$ kg/cm², which is more than the carrying capacity of a mild steel column of the same circumscribed sectional area and of having an average slenderness ratio. The participation of concrete resistance decreases as reinforcement increases, while the participation of the compressive resistance taken on by the steel reinforcement increases in the Table up to 82%. Such columns behave almost like steel columns, although concrete is absolutely indispensable.

c) Use of high-tensile steel for compression members and columns.

The use of high-tensile steel for columns, arches and other compression members offers new possibilities in dimensioning of sections. With reference to the requisite external dimensions, competition with steel is all the more easy, if the reinforcement is of higher quality. It is practically always necessary to use a good quality of concrete even if its participation in load-bearing is comparatively low.

Fig. 1 shows to scale the dimensions of the sections which, under various assumptions, are required for a load of 1000 tons.

- 1) An ordinary longitudinally reinforced column of structural concrete with $\sigma_{b,zul} = 35$ kg/cm² and with a percentage of reinforcement of St 37 of $\mu = 0.8$ %.
- 2) The same conditions but with high-grade concrete of $\sigma_{b,zul} = 70$ kg/cm².
- 3) A laterally bound reinforced concrete column of high-grade concrete with $\sigma_{b,zul} = 70$ kg/cm² and reinforcement of steel St 37.
- 4) A concrete encased steel column made of rolled section of St 37 with $\sigma_{e,zul} = 1400$ and $\sigma_{b,zul} = 60$ kg/cm².
- 5) A laterally bound reinforced concrete column of high-grade concrete ($\sigma_{b,zul} = 60$ kg/cm²) and of steel with: $\sigma_s = 6000$ ($\sigma_{e,zul} = 2400$ kg/cm²) with a safety factor of 2.5.
- 6) A column made of steel only (St 37) with $\sigma_{e,zul} = 1400$ kg/cm². (The dotted line shows the outline of a possible encasing).

The *structural design* of compression members with high-grade steel reinforcement call for special measures. A transmission of the longitudinal forces by adhesion (grip) alone, as exists in ordinary reinforced concrete construction, will not be possible. The longitudinal bars are best jointed by butt-welding. In order to induce greater individual forces in the columns, special design would seem indispensable. The uniting of the longitudinal bars in order to obtain a rigid skeleton is generally effected by welding on hooping straps. *Dr. Bauer* has made a number of suggestions concerning the connections for joining the girders to the

columns and for assemblage in general. The reinforcing skeleton consisting of the longitudinal bars and the lateral reinforcement has to be tied together in the workshop and then erected on the building site as though it were a steel column.

Quite often it will be advantageous to combine the light steel framework of columns and girders of welded, riveted or bolted, execution with the ordinary

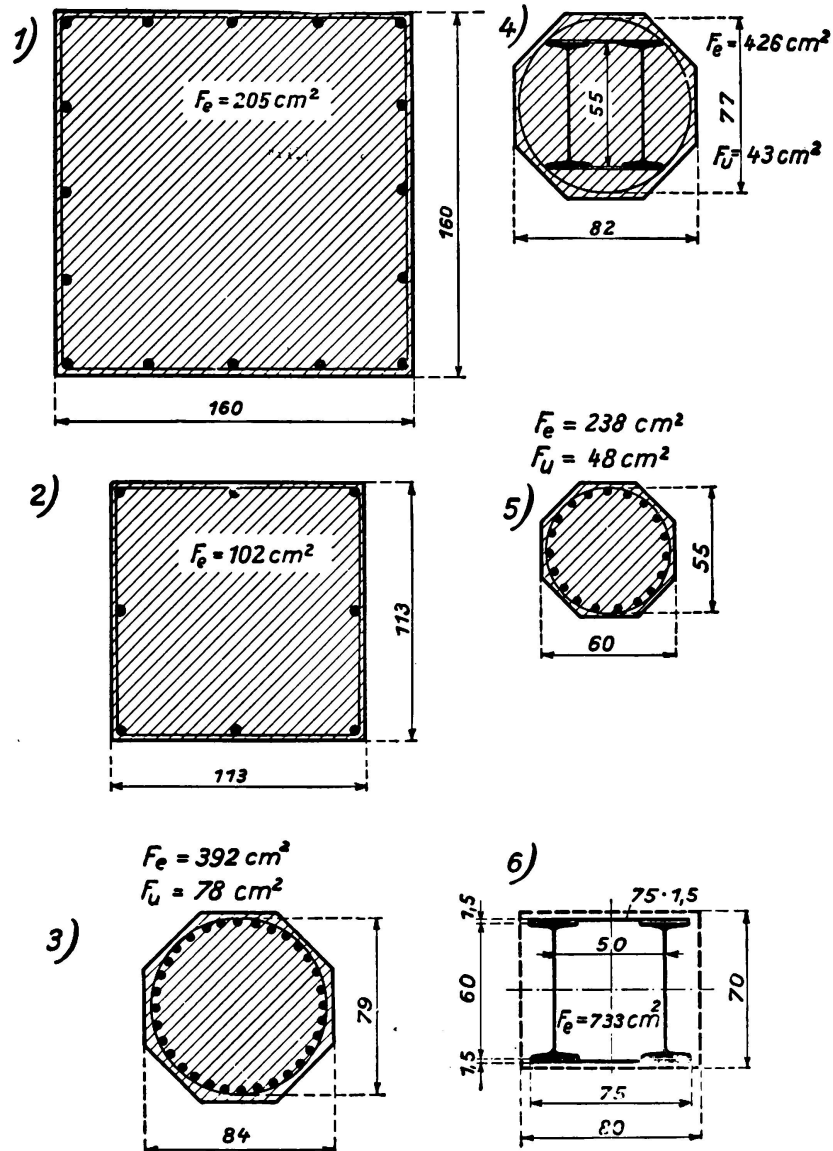

Fig. 1.

type or high-grade round bar steel reinforcement, in order to obtain a far reaching adaptation of all materials to the effects of forces, and to obtain this way more economy. This composite style of construction, which has been carried out quite frequently in Austria, England and America, represents a healthy development of both steel construction reinforced concrete construction, because it offers a technically correct combination of both these types of construction and because the inert concrete encasing added to steel structures, which is often necessary as a means to withstand fire and corrosion, is used for the transmission of forces.

B. Beams with high-grade steel reinforcement.

a) Tests.

The experiments carried out from 1912 to 1913⁴ on T-beams with a length of 2.7 m and a reinforcement percentage of 1.5, where yield stresses of the steel were 2.5 to 3.5 tons/cm², showed a ratio of maximum stress in the steel of $\sigma_e : \sigma_s = 1.05$ to 1.09 to the yield limit.

The fundamental experiments carried out with Isteq steel reinforcement⁵ were made in the years 1927 and 1928 and the results showed that with a twisting having a pitch 12.5 times the thickness of the bar, the maximum effect was attained with 1.5 increase of the yield limit as compared with the non-twisted steel, and a 1.1 increase of tensile strength, while the modulus of elasticity of the steel was reduced to $E_e = 1700$ tons/cm². Eight girders with a cross-section of 20 · 30 cm were used for purposes of comparison of the grip resistance of the Isteq steel; while experiments with 12 reinforced concrete beams with cross sections of 10 · 20, 15 · 20, and 20 · 20 cm and with three different percentages of reinforcement varying between 0.4 and 1.8% showed that the reinforcement of the Isteq steel absorbed 1.43 to 1.5 times the amount of stress as similar girders with St 37 reinforcement, and that in addition, the ratio $\sigma_e : \sigma_s = 1.2$ was observed in the case of light reinforcement and 1.1 in the heavier reinforcement. Four slabs were tested for comparison purposes, they were reinforced with Isteq steel and St 37 in percentages of 0.24 or 0.38 and the ratio of steel stresses at moment of fracture was found to be 1.53. The ratio $\frac{\sigma_e}{\sigma_s}$ was an average of 1.3 for all four slabs.

The tests⁶ carried out in 1928 concerned 36 T-beams each 2.7 m long of which 8 beams were reinforced with St 48, six with St 80, four with Isteq steel, and eight, for purposes of comparison, with St 37. Two qualities of concrete — 150 and 300 kg/cm² cubic resistance were provided. The percentages of longitudinal reinforcement was abt. 0.5, 1.1 and 1.7%. The following were the most important results: the quality of the reinforcement steel used had no influence on the deflections or the formation of cracks with identical stressing of the steel below the yield limit. The quality of the concrete had also no important influence within the zone of comparable steel stresses. The carrying capacity for all high-grade steels, where the fracture was caused by the effects of moments, depended on the yield point stress, just the same way as for reinforcement of St 37. The demands on the composite structure prove greater the higher the steel stresses. Where other conditions are identical high concrete strength increases the effect of composite action and raises the carrying capacity when the latter is dependent on the compound action of the two materials.

In 1932 experiments were carried out⁷ on eight beams of T-section, rein-

⁴ Schubwiderstand und Verbund (Shearing strength and composite structures), Springer, Berlin, 1913; and Zeitschrift für Betonbau, 1913, Issue 8, 9; 1914, Issue 1.

⁵ Beton und Eisen, 1928. P. 233 et seq.

⁶ Bauingenieur, 1929, Nr. 7.

⁷ Issue 14 of the Austrian Commission on reinforced concrete. Versuche an Balken mit hochwertiger Stahlbewehrung und an streckmetallbewehrten Platten (Tests on beams with high-grade steel reinforcement and slabs reinforced with expanded metal). Vienna, 1932.

forced with St 55. The yield limit was: $\sigma_s = 3.7$ tons/cm², the tensile strength of the reinforcement 6.2 tons/cm². The cube strength was 265 and the prism resistance 218 kg/cm². The upsetting was measured to be 2⁰/₀₀ on an average. The main results were as follows:

Percentage of reinforcement	=	0.34	0.73	1.1	1.45 %
Formation of cracks based on calculated steel stresses	$\sigma_e =$	1200	800	800	650
Rupture based on calculated steel stresses	$\frac{\sigma_e}{\sigma_s} =$	1.3	1.2	1.1	1.03.

During the years 1930—1932⁸ fatigue and ordinary static bending tests were carried out with 32 T-beams with eight different kinds of reinforcement, in sets of four identical test pieces. The most important results were:

Percentage of reinforcement	$\mu =$	0.56	0.85	1.4 %	
		Istegsteel	St 37	St 55 Istegsteel	
Stress at the moment of cracking		1100	900	700	700 kg/cm ²
Maximum stress $\frac{\sigma_e}{\sigma_s}$	=	1.45	1.12	1.10	1.23

In reinforced concrete slabs with expanded metal reinforcement⁹ of 4300 to 5300 kg/cm² tensile strength without yield limit and with a percentage of reinforcement of 0.27 to 0.57 %, the highest steel stresses for rupture were $\sigma_e = 4600$ to 5000 kg/cm² (average = tensile strength).

Comparison tests carried out with beams reinforced with St 37 and on girders with Tor-steel reinforcement¹⁰ gave the following results:

	St 37 with $\sigma_s = 2.8$		Tor-steel of $\sigma_s = 4.6$ tons/cm ²			
$\mu =$	0,69		0,37	0,70		1,43 %
σ_p	94	162	94	94	162	162 kg/cm ²
$\frac{\sigma_e}{\sigma_s} =$	1,11	1,27	1,19	1,07	1,30	1,10

Further important data concerning the behaviour of high-grade steel was obtained by experiments carried out by the German Commission on reinforced concrete¹¹ in which St 37, St 48 and Si-Steel were used and further those of the Austrian Commission on reinforced concrete¹².

⁸ Issue 15 of the Austrian Commission on reinforced concrete, 1935.

⁹ Issue 14 of the Austrian Commission on reinforced concrete, 1935.

¹⁰ Not yet published.

¹¹ Issue 66, 1920.

¹² Issue 7 (1918), Issue 14 (1933).

We would mention information taken from these latter tests:

Percentage of reinforcement	$\mu =$	0.39	0.78	1.77	2.65 %
With St 55 and inferior quality of concrete	$\frac{\sigma_e}{\sigma_s} =$	1.35	1.14	< 1	< 1
With St 55 and high-grade concrete	$\frac{\sigma_e}{\sigma_s} =$	1.45	1.31	1.21	1.08
With Isteg-steel and high-grade concrete	$\frac{\sigma_e}{\sigma_s} =$	1.60	1.48	1.34	1.17

b) *Deflection and formation of cracks.*

Within the range of tests which includes steel of $\sigma_s = 2.2$ to nearly 5 tons/cm², beams of high-grade steel reinforcement, behave in the same way as girders of St 37 as regards deflection and formation of cracks under similar stresses below the yield limit, provided that the shape and surface of the reinforcing bars and the quality and composition of the concrete are the same. The first cracks occurred for bending tensile stresses (calculated according to the condition I with a coefficient n, corresponding to the ratio $E_c : E_b$ for low stresses), which more or less correspond to the bending-tensile stresses of the non-reinforced concrete beams. The actual steel stress in existence just before the first crack occurs depends on the ductility of the concrete. At extreme fibres of the beam the ductility has a value of 1 to $3 \cdot 10^{-4}$, to which corresponds an actual tensile stress of the reinforcing bars of $\sigma_{ez} = 150$ to 500 kg/cm². The stress in steel $\sigma_{e II}$, acting after (assumed) complete cracking of the concrete tensile zone, (calculated according to condition II for $n = 15$), is very variable with the percentage of reinforcement $\mu = \frac{F_e}{b h}$. In this connection b presents the width of the tensile zone of the concrete. According quantitative values this observation also holds good for T-beams where b stands for the width of the web. Where the tensile strength of concrete is $\sigma_{bz} = \frac{\sigma_p}{6}$ ¹³

the ratio $\frac{\sigma_{e II}}{\sigma_p}$ given in Fig. 2 can be approximately applied:¹⁴

$$\sigma_{e II} = \left(1 + \frac{0,035}{\mu} \right) \sigma_p \tag{3}$$

Before the first crack forms the stresses in the concrete are transmitted to the steel by adhesive forces. On account of a certain lack of homogeneity in the composition of the concrete and the steel surface these forces are unevenly distributed. In one place the reinforcing bars show signs of yield and this signifies that the first crack on the point to be formed. The distribution of the (grip) adhesive stresses τ , (slipping and friction) of the tensile stresses in concrete σ_{bz} and the tension in the steel σ_e are shown in Fig. 3 as being situated between two

¹³ Average resulting from a number of experiments.

¹⁴ Cp. *Saliger: Der Eisenbeton (Reinforced concrete)*, 6th Edition, P. 165 et seq.

neighbouring cracks. If the curved line τ , is replaced by straight lines, as shown dotted in the Fig., we receive for the rectangular section, for the difference in tensile ΔZ which is transmitted by the concrete to the tensile reinforcement, having a circumference u , the following relation

$$\Delta Z = F_c \cdot \Delta \sigma_e = \frac{b d^2 \sigma_{bz \max}}{6 z} = \frac{u e \tau_{1 \max}}{4}$$

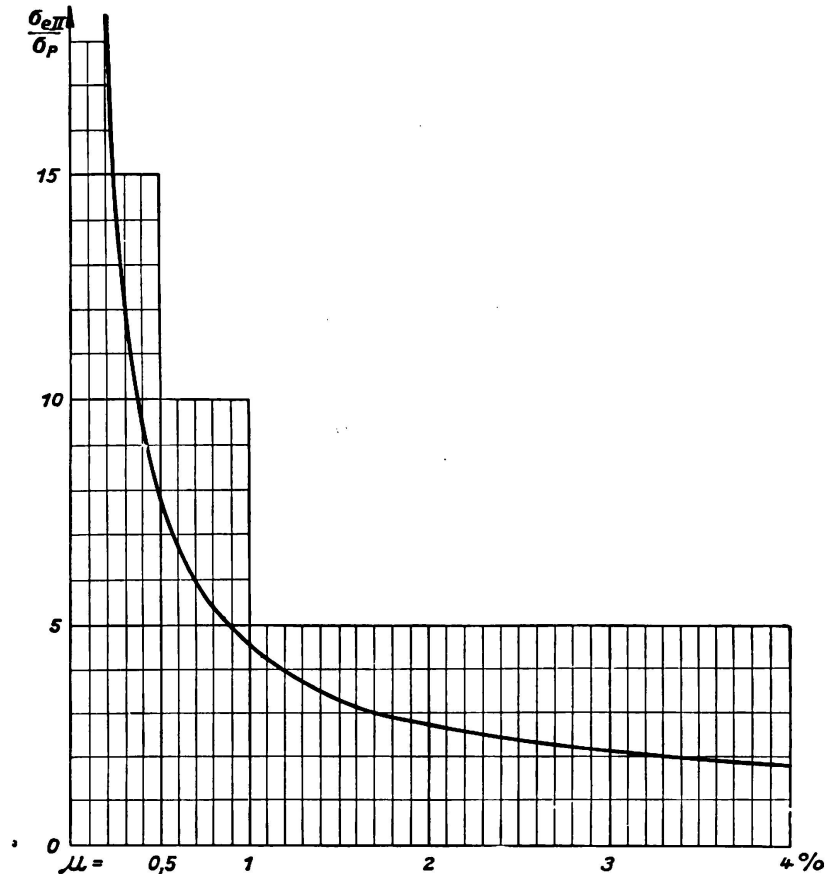

Fig. 2.

From this probable average distance of the cracks can be calculated as follows:

$$e = \frac{2 b d^2 \sigma_{bz \max}}{3 u z \tau_{1 \max}} \tag{4}$$

with $z = 0.9h$ and $h = 0.9d$ we obtain:

$$e = \frac{0,9 bh \sigma_{bz \max}}{u \tau_{1 \max}} \tag{4 a}$$

These expressions show that the distance between cracks with the same adhesive surface u increases with increased depth and width of the beam. Taking m as the number of reinforcing bars, we receive for round bar reinforcement

$$u = m d_e \pi = \frac{4 F_e}{d_e}$$

If $\mu = \frac{F_e}{bh}$ then:

$$e = \frac{0,23 d_e \cdot \sigma_{bz \max}}{\mu \tau_{1 \max}} \tag{4b}$$

From this ratio it will be seen that the interval between the cracks diminishes as the grip resistance of the reinforcement in the concrete (that is where the surface is very rough, as with Isteg-steel and indented bars) increases and in proportion as the reinforcement has more strength, also when the bars are thinner and when the concrete tensile strength is lower. When the tensile strength

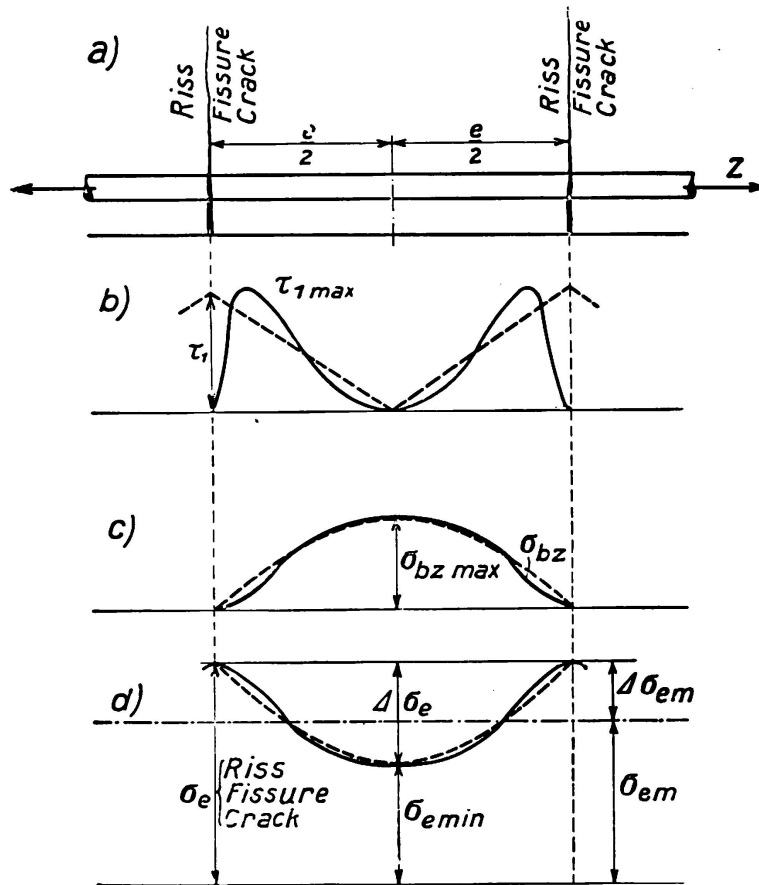

Fig. 3.

is lower there will be less adhesive resistance, and in this way the influence of the quality of the concrete is practically eliminated. If the approximations

$\sigma_{bz} = \frac{\sigma_p}{6}$, and also the tensile strength $\sigma_z = \frac{\sigma_{bz}}{2} = \frac{\sigma_p}{12}$, are introduced we receive $\tau_1 = \sqrt{\sigma_p \sigma_z} = 0.3 \sigma_p$ then the average distance between cracks in the case of round bar reinforcement will be:

$$e = \frac{0,13 d_e}{\mu} \tag{4c}$$

For instance, with $d_e = 2$ cm and $\mu = 0.01$ the distance between the cracks will be $e = 26$ cm.

When the load on the girder is increased, the slipping movement of the steel reinforcement will also increase and the result will be the distribution of stresses shown in Fig. 4. The comparatively slight resistance to friction or to the movement of slipping of the steel will be the only action exerted in the neighbourhood of the cracks, and the entire grip resistance will only come into play at some

further distance from the cracks. The length e_1 is determined by the ductility of the concrete and approaches a definite minimum value for the maximum stresses in the steel. As the stresses in the steel increase, the length e_1 , over which the whole of the grip resistance can develop, becomes shorter.

The width of the crack is:

$$\Delta e = k_R \varepsilon_R e_2.$$

In this formula $k_2 < 1$ is a coefficient which represents the distribution of steel stresses in the neighbourhood of the crack and the distortion of the concrete which is caused by the local shearing stress resulting from the grip

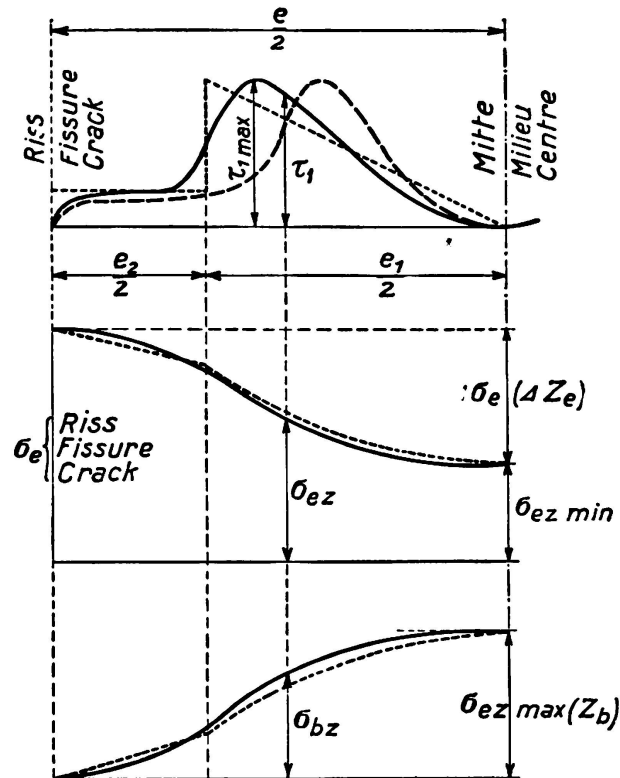

Fig. 4.

resistance¹⁵. The factor ε_R is the specific elongation of the steel at the crack. For instance, if $\sigma_c = 2100 \text{ kg/cm}^2$, then $\varepsilon_R = 10^{-3}$. With $e = 260 \text{ mm}$ under the assumption that $e_2 = \frac{e}{2} = 130 \text{ mm}$ and $k_R = \frac{2}{3}$, then $\Delta e = \frac{2}{3} \cdot 10^{-3} \cdot 130 = 0.09 \text{ mm}$. If $\sigma_{cR} = 3150 \text{ kg/cm}^2$ (with high-grade steel, below yield limit) then $\varepsilon_R = 1.5 \cdot 10^{-3}$ and with $k = 0.9$ the width of the crack will be: $\Delta e = 0.9 \cdot 1.5 \cdot 10^{-3} \cdot 130 = 0.18 \text{ mm}$. If the intervals between the cracks are smaller than those assumed above or those in the present example, for instance, in the case of artificially increased surface roughness, then the individual cracks will be less wide¹⁶. In the most unfavourable circumstances the cracks

¹⁵ The shearing distortion of the concrete at the steel reinforcements may increase the apparent ductility of the concrete very considerably.

¹⁶ Ausführliche Rißbeobachtungen (Observations on Cracks) N° 15 of the Austrian Commission on reinforced concrete (Fatigue tests) and punching tests (not yet published).

might have the width which corresponds to the elongation of the steel in the zone between two cracks. According to the experiments¹⁷ which have been carried out, the widths of the cracks from 0.2 to 0.3 mm are not important from the point of view of protection against corrosion of the steel when high-grade concrete is being used. From this it follows, that from the point of view of crack formation the use of high-grade steel and in particular steel with artificially roughened surface, and the admission of high stresses up to 2200 kg/cm² in heavily reinforced structural elements (webs of T-beams) and up to 2500 kg/cm² in less strongly reinforced beams (rectangular beams and slabs) is permissible without the durability being reduced. Of course it is assumed in this connection that the work is of good quality and that sufficient safety against shearing effects is guaranteed.

c) *Demands made on shearing resistance.*

As the quality of the steel increases, so does under otherwise equal conditions the resistance to shear stresses and compound action in reinforced concrete beams on account of greater shear forces. No new rules and regulations are required for this. The thesis enunciated on the basis of tests and theory referring to reinforcement of St 37 suffice. The measures deduced from tests with St 37 reinforcement and applied to structural designing have been confirmed in every respect by tests made with beams reinforced with high-grade steel. The tests made with high-grade steel have shown, in particular, that the use of better quality concrete is only necessary when the compressive and shearing stresses of the concrete are so high that the quality must be raised. The same can be said of the grip forces. In order to keep these below the permissible limits, it will be necessary to increase the adhesive surface by employing a greater number of the reinforcing bars of smaller diameters. The radius of the bends at the bending points of the inclined bars and of the hooks at the end must be increased in order to prevent local overstressing of the concrete, which may result in cracks. At the points of bending a radius of 5 d_c is rarely sufficient. It should be increased to at least 10 d_c . The measures aiming at improving the compound action are similar to those taken for ensuring satisfactory shearing resistance.

d) *The plastic range under rupture conditions.*

With heavily reinforced beams the cause of fracture is connected with the surmounting of the compressive resistance of the compression zone of concrete, while the tensile strength of the reinforcement is not being fully utilised. The use of high-tensile steel is therefore useless in such a case (unless it were possible to produce high-grade steel with a still higher modulus of elasticity E_s).

Beams which are only lightly reinforced fracture when the tensile resistance is overcome. It is with these where the properties of high-tensile steel are of importance. For this reason we are now only considering light reinforcement. Later on we shall explain what is meant by tensile resistance and also take up

¹⁷ Tests made by Honigmann: Beton und Eisen 1935. P. 307.

the question of the limit which determines one or other of these resistances and which depend on the good quality of the concrete or the steel.

The tests proved that in lightly reinforced beams the cause of fracture was also the crushing of the compressive zone in the concrete. The reason of this phenomenon lies in the fact that owing to great expansion of the tensile reinforcement, the pressure zone becomes considerably reduced, the consequence of this being that compressive stresses grow to such an extent that the zone of pressure is destroyed and the carrying capacity exhausted. This confirms the fact that for heavily and lightly reinforced members the compressive resistance of the concrete is overcome in the state of fracture, this being at once where the reinforcement is heavy and more gradually where it is light.

In the state of fracture the pressure in the compressive zone is distributed according to the curved line seen in Fig. 5. The maximum stress is the prism

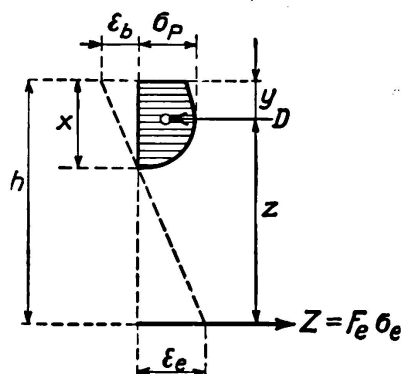

Fig. 5.

strength σ_p of the concrete. For well known reasons, it is lower than the cube strength σ_w . A number of experiments have shown that $\sigma_p = 0.7$ to $0.9 \sigma_w$ and $0.75 \sigma_w$ can be taken as the average figure. The effective compressive force is $D = kb x \sigma_p$.

Here the coefficient k , in accordance with experiments which have been made and according to the behaviour of the concrete under deformation, is 0.8 to 0.9 , $k = 0.85$ can be taken as an average. The position of the centre of compression D is related to k and may be expressed as $y = \frac{kz}{2}$. The tensile force of the reinforcement is $Z = F_e \sigma_e$. We indicate the proportion of the depth of the compressive zone to the depth of the beam by $\xi = \frac{x}{h}$, the participation of the reinforcement by: $\mu = \frac{F_e}{bh}$ and the ratio of the tension in steel σ_e , present when fracture occurs, to the prism strength of the concrete with $\beta = \frac{\sigma_e}{\sigma_p}$. Thus we receive with the above terms:

$$\xi = \frac{\beta \mu}{k} \quad (5)$$

The nominator $\beta \mu$ is the measure for the reinforcement and the depth from which we see that the ratio of the zone of pressure to the depth of the beam

is in direct relation to the amount of reinforcement. For the state of fracture of lightly reinforced beams we have: $\sigma_e \geq \sigma_s$, therefore $\sigma_e = \alpha \sigma_s$, and hence the ratio $\beta_s = \frac{\sigma_s}{\sigma_p} = \frac{\beta}{\alpha}$ indicates a definite criterion of the qualities of the material.

With steel having an actual yield limit, for instance, St 55 in Fig. 6, the stress in the steel within the zone of yield from ϵ_s to ϵ'_s is a fixed value, thus: $\sigma_e = \sigma_s$. With greater elongations $\epsilon > \epsilon'_s$ (zone of hardening) is $\sigma_e > \sigma_s$.

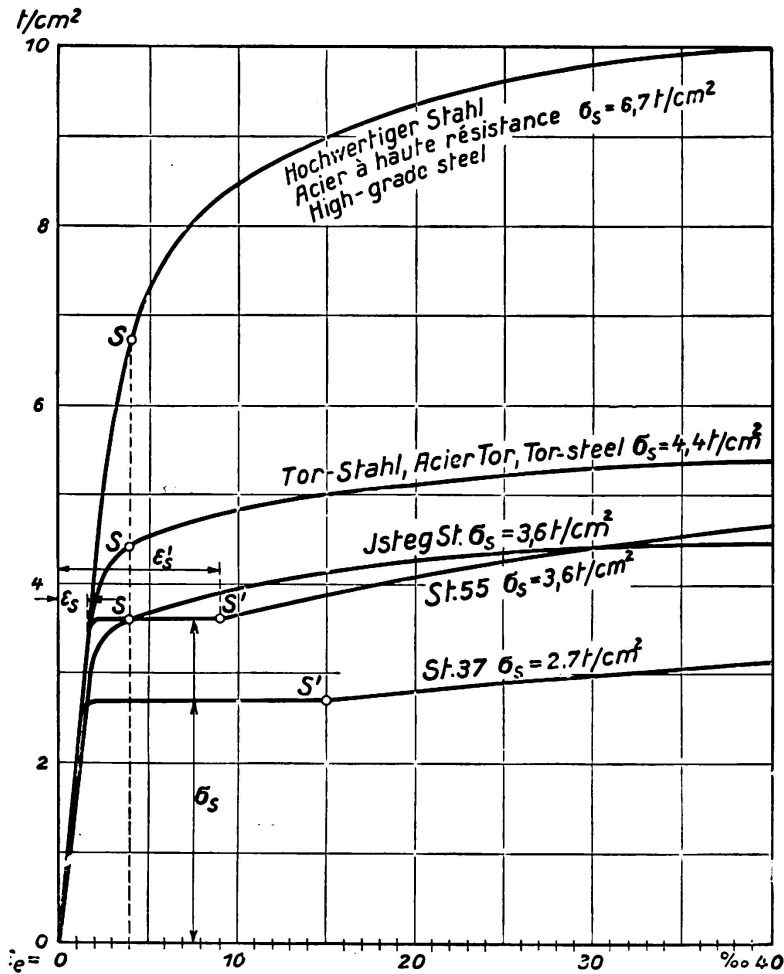

Fig. 6.

Where steel has a yield limit by definition for instance, Isteg steel with a yield limit of 0.4 ‰, as shown in Fig. 6, is $\sigma_e > \sigma_s$, if the elongation is greater than the yield expressed by definition.

Fig. 5 shows $\xi = \frac{x}{h} = \frac{\epsilon_b}{\epsilon_b + \epsilon_e}$.

The quantity ϵ_b is 2 to 7 ‰ as has been received from tests $\epsilon_b = 5 ‰$ can be taken as the average value. The lever arm of the internal forces is

$$z = h - y = h - \frac{kx}{2} = \left(1 - \frac{k\xi}{2}\right)h = \left(1 - \frac{\beta\mu}{2}\right)h$$

With $M = Dz - Zz$ and substituting the above coefficients we obtain the carrying coefficients:

$$\left. \begin{aligned} m &= \frac{M}{bh^2\sigma_p} = \frac{\beta_s\mu}{2} (2 - \beta_s\mu) = \frac{\alpha\beta_s\mu}{2} (2 - \alpha\beta_s\mu) \text{ and} \\ m' &= \frac{M}{bh^2\sigma_s} = \frac{m}{\beta_s} = \frac{\alpha\mu}{2} \cdot (2 - \alpha\beta_s\mu). \end{aligned} \right\} \quad (6)$$

First case. $\sigma_e = \sigma_s$ or $\alpha = \frac{\sigma_e}{\sigma_s} = 1$ (*light reinforcement*).

As $\beta_s\mu = k\xi$, we find in the zone of yield that for St 55 with about $\varepsilon_e = 1.7$ to $9\%_{00} = 0.74$ to 0.35 , $\beta_s\mu \cong 0.6$ to 0.3 for Isteg steel and other high-grade steels with yield limit fixed by definition $\varepsilon_e = 4\%_{00}$ $\xi = 0.55$ $\beta_s\mu \cong 0.45$.

For instance, given a beam with = 1.4% reinforcement of St 55 $\sigma_s = 3500$ and $\sigma_p = 150$ kg/cm², then $\beta_s = \frac{3500}{150} = 23.2$ and $\beta_s\mu = 23.3 \cdot 0.014 = 0.33$. This value is situated between 0.6 and 0.3. For that reason the maximum stress in steel, for the state of fracture, is equal to the yield limit. The limit of reinforcement will exist when $\beta_s\mu = 0.6$. With the above ratios $\mu = \frac{0.6}{\beta_s} = \frac{0.6}{23.3} = 0.026$, i. e. a beam with reinforcement which is less than 2.6% will break by overcoming the tensile resistance of the steel; where the reinforcement is higher than 2.6%, the tensile resistance will not be utilised to the full and the direct cause of fracture will be found in the crushing of the concrete. In dealing with these steels we speak of light reinforcement, when, assuming St 55 $\beta_s\mu < 0.6$ and for Isteg girders and other high-grade steels with yield limits expressed by definition: $\beta_s\mu < 0.45$.

For $\alpha = 1$ the carrying coefficient mentioned above:

$$m = \frac{M}{bh^2\sigma_n} = \frac{\beta_s\mu}{2} \cdot (2 - \beta_s\mu) \quad (6a)$$

From this it will be seen that the carrying coefficient depends only on $\beta_s\mu$. For equal quality of concrete σ_p the ratio $\frac{\sigma_s}{\sigma_p}$ increases, the higher the quality of the steel; thus μ can be proportionately smaller in order to obtain the same carrying capacity. If therefore we replace a steel having a yield limit of σ_{s1} and a percentage of reinforcement μ_1 by another steel with a higher yield limit σ_{s2} and μ_2 as its percentage of reinforcement, the bearing capacity of the beam will remain the same if $\sigma_{s1} \cdot \mu_1 = \sigma_{s2} \cdot \mu_2$ or if $\mu_2 = \frac{\sigma_{s1}}{\sigma_{s2}} \cdot \mu_1$.

As a matter of fact in this case the compressive stress in the concrete laid down by the usual calculation for n ($= 15$) increases. However as this does not represent a measure of compression resistance and with it the safety of the concrete pressure zone, the permissible stresses in the usual calculation can be increased, without reducing the safety factor in the concrete pressure zone.

If, for instance, $\frac{\sigma_{s1}}{\sigma_{s2}} = \frac{2400}{3600} = \frac{2}{3}$, then $\mu_2 = \frac{2}{3} \mu_1$.

An increase of the concrete stresses rated at n corresponds by an average of 15% to the reduced quantity of reinforcement μ_2 . The permissible stress can be increased by this amount. The depth of the compression zone while in a state of fracture is not changed by an equivalent reinforcement capable of equal resistance. (See formula 5). The carrying coefficient $m' = \frac{M}{b h^2 \sigma_s} = \frac{\mu}{2} (2 - \beta_s \mu)$ shows clearly what the influence of the quality of the concrete is. As the concrete resistance σ_p decreases, so the $\beta_s = \frac{\sigma_s}{\sigma_p}$ increases if the steel remains of unchanged quality. At the same time there is a reduction, even if only slight, of the carrying capacity of the beam or else a larger amount of reinforcement will be necessary in order to obtain the same carrying capacity.

Second case. $\sigma_e > \sigma_s$, or $\alpha = \frac{\sigma_e}{\sigma_s} > 1$ (*very light reinforcement*).

When reinforcement is only light the stress in the steel of the beam when in a state of fracture reaches the zone of hardening and for that reason it exceeds the yield limit. The tensile resistance of the reinforcement is greater than what would correspond to the yield stress. The ratio α follows the formula given below for reasons explained elsewhere¹⁸:

St 55 $\alpha = \frac{\sigma_e}{\sigma_s} = 0,9 + \frac{0,03}{\beta_s \mu}$ valid for $\beta_s \mu = 0,07$ to $0,3$

for Istegsteel and other high-grade steels without pronounced yield limit

$\alpha = \frac{\sigma_e}{\sigma_s} = 0,93 + \frac{0,035}{\beta_s \mu}$ valid for $\beta_s \mu = 0,1$ to $0,6$

To these coefficients correspond elongations in steel for the state of fracture up to about 40⁰/₀₀. When making experimental observations concerning distribution of cracks and taking into consideration the statements made in connection with Point b) they led to various crack-widths of the order of 2 to 5 mm. Elongations of steel above 40⁰/₀₀ do not occur as a rule in steel when used for reinforcing. Therefore it is immaterial for the carrying capacity of ferro-concrete beams how far the fracture elongation of the test piece exceeds the maximum elongation of the steel as used in reinforced concrete beams. The further course followed by the stress strain curve is of no importance as far as reinforced concrete beams are concerned. It is therefore not justified to demand for the purpose of reinforcement, steels of much higher rupture elongation than 40⁰/₀₀, it suffices with say 60⁰/₀₀. If the reinforcement steel has a lower rupture elongation, then the maximum load will have been reached when the reinforcement bars fracture¹⁹.

¹⁸ Beton und Eisen 1936.

¹⁹ 6. 14 of the Austrian Commission on reinforced concrete. Versuche mit Streckmetallplatten (Experiments on ductile metal plates). P. 102 et seq.

Fig. 7 gives the $\alpha = \frac{\sigma_e}{\sigma_s}$ -coefficients for St 55 and high-grade steel without the yield limit and also the coefficients of St 37 for purposes of comparison.

Fig. 8 gives the carrying capacity $\frac{M}{b h^2}$ for concrete with $\sigma_p = 150 \text{ kg/cm}^2$ and reinforcement of high-grade steel of $\sigma_s = 6.7 \text{ tons/cm}^2$, $\sigma_s = 3.6 \text{ tons/cm}^2$ (St 55 and Isteg-steel, in the latter case also for concrete with $\sigma_p = 100$ and 200 kg/cm^2 , dotted), and St 37 $\sigma_s = 2.4 \text{ tons/cm}^2$ for purposes of comparison.

From this we deduce:

1) When in a state of fracture the tension in the reinforcement exceeds the yield limit to a greater extent in proportion as the amount of reinforcement $\beta_s \mu$ is smaller. Where $\beta_s \mu$ is equivalent, Isteg steel and other high-grade steel

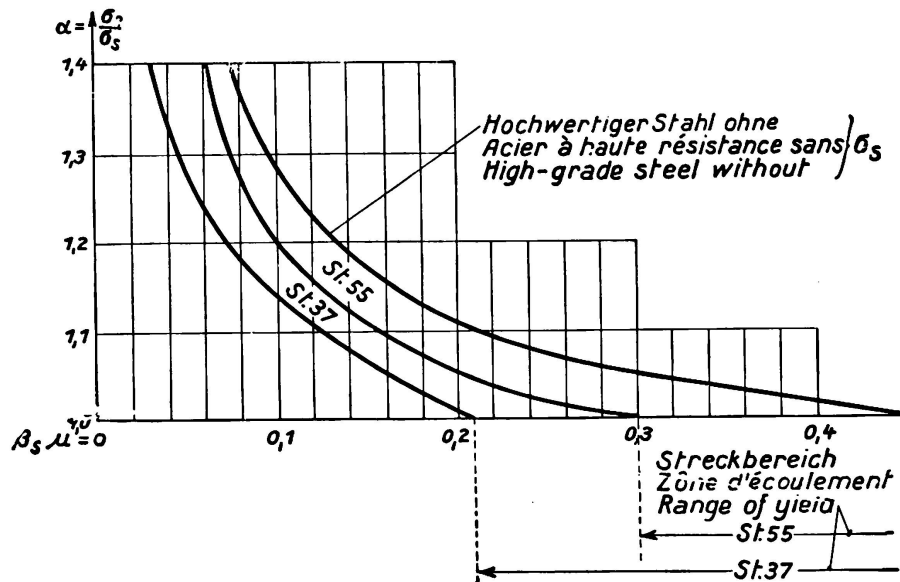

Fig. 7.

without any marked yield limit of higher stresses (corresponding to their yield limit by definition) are as satisfactory as St 55 and the steel with higher tension as satisfactory as St 37. Expressed in general terms this means that where the elongation of the reinforcement is greater, its utility will be less provided the conditions are equivalent.

2) Where the concrete strength σ_p is lower, β_s will be greater with the same quality of steel. Where the amount of reinforcement is equal $\beta_s \mu$ will be greater and thus $\alpha = \frac{\sigma_e}{\sigma_s}$ will be smaller, that is, the carrying capacity of very lightly reinforced girders will be considerably reduced with reduced quality of the concrete. High-grade concrete increases the carrying capacity considerably. For instance, for concrete of $\sigma_p = 100 \text{ kg/cm}^2$, $\beta_s \mu = 0.20$ for concrete with $\sigma_p = 200 \text{ kg/cm}^2$, $\beta_s \mu$ will equal 0.10. In this connection the stress of $\frac{\sigma_e}{\sigma_s} = 1.05$ rises to 1.20, that is, an increase of 14% in the case of St 55. The carrying capacity rises by very much the same amount.

3) If a St 37 reinforcement of a yield limit of σ_{s1} , and the percentage of reinforcement μ_1 is replaced by a higher grade of steel with a ductile limit of σ_{s2} and with an amount of reinforcement of $\mu_2 = \frac{\sigma_{s1}}{\sigma_{s2}} \cdot \mu_1$, then, provided the $\beta_s \mu$ is the same, the coefficient α of the higher-grade steel will be greater, that is, the utilisation of the higher-grade steel will be greater in proportion to its yield limit and the carrying capacity will be higher too. If, for instance, a St 37-reinforcement with $\beta_s \mu = 0.20$ is replaced by Isteg-steel, then the coefficient of $\alpha = 1.00$ will rise to 1.11. The carrying capacity of the beam reinforced with

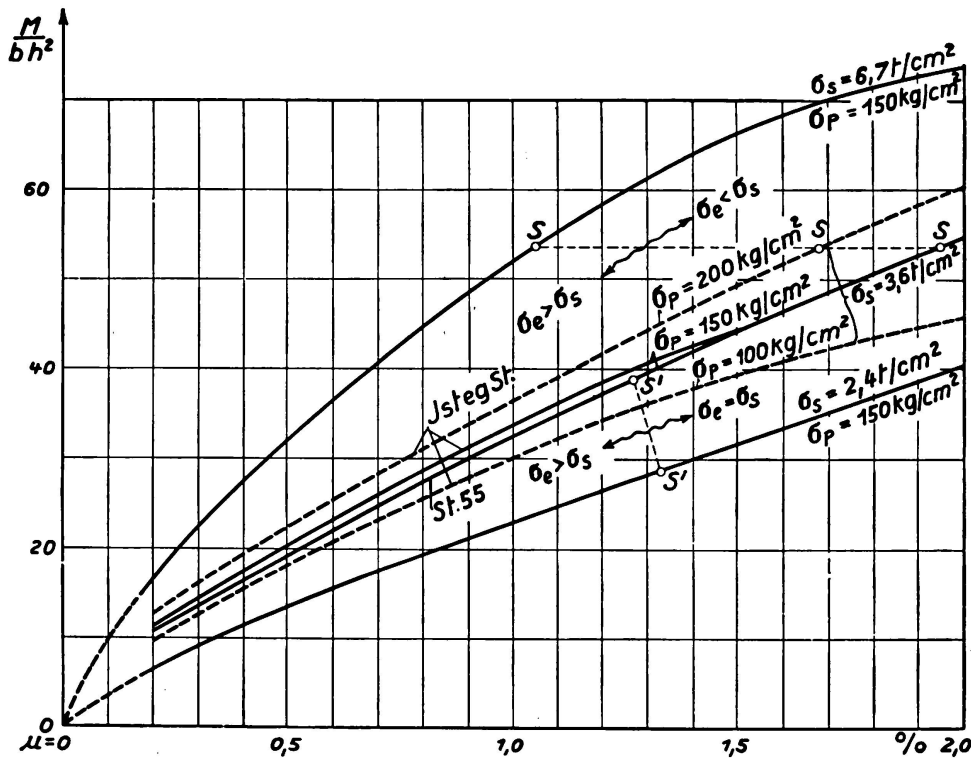

Fig. 8.

Isteg-steel will then be approximately 11% higher or if attempts are made to reach the same carrying capacity, then the reinforcement percentage of the Isteg reinforced girder can be reduced to below the quantity μ_2 determined above.

4) A number of conclusions can be drawn from Fig. 8. For instance, the carrying capacity of beams with equivalent percentage of reinforcement μ increases less than what would correspond to the increased yield limit, that is, reinforcement with twice as high a yield limit corresponds to less than twice the carrying capacity.

If a reinforcement is replaced by one of higher grade, then its section required to reach the same carrying capacity will be considerably less than would be anticipated if from reversed ratios of their yield limits. If concrete with a strength of 100 kg/cm² is replaced by one having a strength of 200 kg/cm², the carrying capacity would be increased by 20 to 25% provided the amount of reinforcement is kept the same or, in order to attain the same carrying capacity, the reinforcement can be reduced by the same amount.

When considering the plasticity of the concrete and of the reinforcement for the state of fracture, it will be seen that a whole series of significant facts concerning the influence of high-grade steels and of concrete quality will be noted which cannot be obtained with the n -process.

e) *Dimensioning.*

The calculation of dimensions of reinforced concrete beams with high-grade steel reinforcement can be effected in the same way as for St 37 reinforcement. Starting from the plastic zone in a state of fracture, the conception of permissible stress and the coefficient n loses its significance. The determination of permissible stresses always gives rise to conjecture and is the cause of complex divergencies of opinion. The simplest way of determining dimensions is by basing them on the quality of the material:

$$\beta_s = \frac{\sigma_s}{\sigma_p}$$

and of the requisite safety factor s , according to the deduction made by formula 6;

$$h = \sqrt{\frac{2}{\alpha \beta_s \mu \sigma (2 - \alpha \beta_s \mu)}} \cdot \sqrt{\frac{s M}{b \sigma_{p \min}}} = \alpha \sqrt{\frac{s M}{b \sigma_{p \min}}} \quad (7)$$

$$F_e = \frac{s M}{z \cdot \alpha \sigma_s} = \mu b h$$

Here, in accordance with a proposal made elsewhere²⁰ $\sigma_{p \min} = \frac{2}{3} \sigma_{p \text{ average}}$ = 0.5 to 0.6 $\sigma_{w \text{ average}}$ and in general, and if necessary, while taking into consideration an increase of impact added to the load, then s should be taken as equal to 2.

f) *Conclusion.*

Even if it is not to be expected that high-grade steel will oust St 37 reinforcement in ferro-concrete construction, there are many possibilities of application of high-grade steel bridge construction and structural engineering, generally used in combination with high-grade concrete which lead to further technical and economic development. The main obstacle to more general utilisation of high-grade steels in the past was due to misgiving entertained regarding an excess of crack formation, and that is why engineers were chary of raising tensile resistance of steel unduly, while maintaining the usual coefficient of safety. Another drawback lies in the commonly held opinion that high-grade steels, in particular those which have an artificially raised yield limit (Isteg-steel, Torsteel, etc.) corrode more readily, wear out more rapidly and cannot meet repeated fatigue tests. This view has not been confirmed by experiment²¹.

Custom, sentiment and outlook often play a part in things of this kind and such prejudices will be thrown aside when the conviction gains ground that mis-

²⁰ Beton und Eisen 1936.

²¹ Dauerversuche an Balken mit St 37, 55, 80 und Istegbewehrung (Endurance fatigue tests on girders with St 37, 55, 80 and Isteg-reinforcement). Issue 15 of the Austrian Commission on reinforced concrete.

givings as to high stresses in steel and its effects upon durability are of little importance, or at any rate much exaggerated and that the main factor is to ensure that the structure be designed by experts and executed by skilled labour. So far Isteg-steel alone has made any real headway in this field of construction, while certain other high-grade steels are used for specialised work. However, this is only a first step on the road to further development of the ferro-concrete industry.

Summary.

This paper deals with the effects produced by high-grade steels used for columns and beams, the data being based on experiment and theoretical considerations. Elastic deformation, crack formation and stresses in composite construction when subjected to small loads (working loads) behave very differently than when subjected to maximum loads (state of fracture). In the latter case both materials come under plastic influence.

The determination of permissible stresses by the methods of calculation practised heretofore and providing for the use of the coefficient n ($= 10$ or 15) does not constitute a reliable standard of safety in the structure. The application of permissible stresses has lost its significance and the proposal is therefore put forward that the determination of the dimensions, both for beams and for columns, should be effected by taking into consideration the quality of the material used and the necessary safety factor as this results from experience.

Leere Seite
Blank page
Page vide