

**Zeitschrift:** IABSE congress report = Rapport du congrès AIPC = IVBH  
Kongressbericht

**Band:** 2 (1936)

**Artikel:** Design and execution of welded structures

**Autor:** Bühler, A.

**DOI:** <https://doi.org/10.5169/seals-3171>

### **Nutzungsbedingungen**

Die ETH-Bibliothek ist die Anbieterin der digitalisierten Zeitschriften. Sie besitzt keine Urheberrechte an den Zeitschriften und ist nicht verantwortlich für deren Inhalte. Die Rechte liegen in der Regel bei den Herausgebern beziehungsweise den externen Rechteinhabern. [Siehe Rechtliche Hinweise.](#)

### **Conditions d'utilisation**

L'ETH Library est le fournisseur des revues numérisées. Elle ne détient aucun droit d'auteur sur les revues et n'est pas responsable de leur contenu. En règle générale, les droits sont détenus par les éditeurs ou les détenteurs de droits externes. [Voir Informations légales.](#)

### **Terms of use**

The ETH Library is the provider of the digitised journals. It does not own any copyrights to the journals and is not responsible for their content. The rights usually lie with the publishers or the external rights holders. [See Legal notice.](#)

**Download PDF:** 02.02.2025

**ETH-Bibliothek Zürich, E-Periodica, <https://www.e-periodica.ch>**

## III b 2

### Design and Execution of Welded Structures.

### Ausbildung und Herstellung geschweißter Bauten.

### Projet et exécution des ouvrages soudés.

A. Bühler,

Sektionschef für Brückenbau, S.B.B., Bern.

#### I. Nature and Measuring of Heat and Shrinkage Stresses.

##### 1) *The Nature of Heat and Shrinkage Stresses.*

In the detailing and manufacture of welded structures, the heat stresses produced by the welding process and the subsequent shrinkage stresses due to cooling demand special attention. When a joint is welded, a large amount of heat must be introduced locally in order to connect weld metal and parent metal by fusion.<sup>1</sup>

In heating the material in the region of the joint, it expands, whilst that lying farther off, remaining comparatively cool, hinders the process of expansion. In the proximity of the joint compression and straining of the material is set up, assisted by the heating, whilst the remaining cross section of a specimen is subjected to bending and tensile stresses, and, in limited cases, may even be stretched.

The cooling of a hot joint and with it the surrounding parent metal, is followed by a counteracting internal resistance of the cooler metal more remote from the joint after these portions have lost their bending and tensile strains. This process finally causes the joint and its immediate vicinity to become subjected chiefly to internal tensile stresses, whilst correspondingly other contiguous parts have to withstand compressive strains. The eccentric position of a joint in respect to the axis of the bar, and the constant occurrence of unequal heating, can cause considerable differences, disturbances and changes in the flow of stress, with the result that a linear distribution of stress no longer exists, especially in the weld metal and its immediate vicinity<sup>2</sup>.

Besides, permanent deformations develop in the weld metal itself and in the contact area between weld and parent metal. Some parts of the material shrink and subsequently stretch again. The deformation of parts of the bar owing to welding, often considerable, prove the existence of high internal stresses<sup>3</sup>.

<sup>1</sup> *Wörtmann*: Schweiz. Bauzeitung 5. XI. 32, Transference of heat: 1150 k cal/kg of the weld metal; the quantity of heat must be dependent on the number of welded layers and the dimensions of the parts to be welded.

<sup>2</sup> *Bierett*: Tests to determine shrinkage stresses. Z.V.D.I. 9. VI. 34.

<sup>3</sup> *Reinhold and Heller*: Indications of shrinkage in the electrically welded Schlachthof Bridge at Dresden.

These characteristics remain in general the same when joining girders of component parts or trussed steel structures composed of different members. In the latter case, in addition to the internal stressing mentioned, stresses occur which develop from the reciprocal coercion caused by changes in the length of the members and girders. This fact has to be particularly watched in the strengthening of bridges.

It is clear that under such circumstances the heat stresses and subsequent shrinkage stresses can only be approximately determined, since the deformations lie partly in the plastic region. It is therefore not surprising that materials used in welding must have a high elongation if fractures are to be avoided. (Fig. 1.)

If necessary, welded parts can be more or less heated after welding, or be annealed and subsequently slowly cooled, so as to reduce or nullify the internal

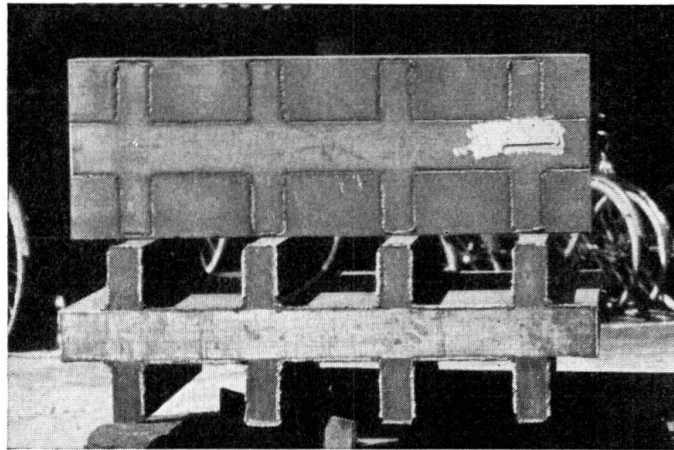

Fig. 1.

Failure in welding a rail-steel plate to steel St 37. After cooling the welds broke out of the high carbonsteel.

stresses. Yet these processes are not often employed, and, in the case of smaller workshops that carry out most of their work with welding, are usually impracticable<sup>4</sup>. It is, however, chiefly the small and medium-sized workshops that go in for electric welding, for the equipment required is not very expensive and is permanently ready for operation.

Under certain circumstances it is of great advantage in the cases of thick pieces to weld them in a warm condition ( $100^{\circ}$  to  $300^{\circ}$  C, i. e.  $212^{\circ}$  to  $572^{\circ}$  F.)<sup>5</sup>. If preheating can be effected without inconvenience to the workmen, it ought to be possible to reduce the shrinkage stress considerably by welding in this condition.

## 2) Devices for Measuring Heating and Shrinkage Stresses.

The measuring of heat stresses has to my knowledge been but seldom undertaken, because it is difficult to work with sensitive instruments in the zone

<sup>4</sup> The penstocks with plates up to 45 mm (1.77 in.) thick at the Etzel water-power station were annealed at a temperature of about  $630^{\circ}$  and maintained at this temperature for 6 hours. By this means the internal stresses caused by welding and the unfavourable structure of the weld joint (Widmannstätten structure) were neutralised. The welds made at site were also annealed.

<sup>5</sup> Escher-Wyss Ltd. Memorandum N<sup>o</sup> 5. May 1928.

of the weld; also, the loss of heat in the air and the flow of heat in the bar itself cause the stressing conditions to change quickly and continuously. Nevertheless, extensometer measurements will show to a certain extent what is taking place in the bars about to be welded.

It is essential for the designer of a structure to know the shrinkage stresses remaining after the equalisation of heat with the surroundings. These can be approximately determined in different ways, namely by:—

- a) Measurement of the change in distance between two points before and after welding.
- b) Borings and measurement of the expansions set up in the neighbouring material (Mathar)<sup>6</sup>.
- c) Measurement of the lattice spacing by X-ray methods<sup>7</sup>.
- d) Dissection of the specimen piece for elongation tests.
- e) Lacquer treatment (adherent, brittle varnish)<sup>8</sup>.

The modes of testing classified under a, b, c, and e can be regarded as non-destructive, whilst in d the test piece becomes unserviceable. Test c is as yet undeveloped and e is only applicable to such places as are not greatly heated.

We have ourselves used test a, which is simple and does not require great experience in taking measurements.

None of these tests may be deemed perfect. All have the disadvantage that no reliable conclusion can be drawn as to the permanent residual internal shrinkage stress of a bar. Even in the case of dissecting a test piece, it is probable that in spite of thorough precautions the magnitude of the internal stress cannot be determined with certainty. The measurement method therefore remains limited to the determination of the amount of deformations on the surface of a test piece. For practical purposes, however, it has nevertheless to be considered as giving valuable information.

For the measurement of shrinkage stresses an extensometer must be chosen which, unlike the usual extensometer, does not rest on the structure while deformation takes place, but is attached to the surface to be measured before and after deformation.

The application of the extensometer to the structure during deformation of the latter is as a rule out of the question because the time involved would be too long and the pointer of the extensometer deranged by heat, blows or the carelessness of the welders, besides which the instrument itself might be damaged.

The condition that the extensometer should not rest on the structure during welding is fulfilled in the Meyer extensometer (Fig. 2).

Measuring with this type of extensometer has the advantage that for the measurement of all marked places only one measuring apparatus is necessary.

The measuring procedure is as follows (see Fig. 3):— The measured length is determined by the points 1) which are fixed into two countersunk holes provided in the member. The extensometer, which consists of two bars 3) and 4)

<sup>6</sup> *Müllenhof*: Inherent stresses in welded joints. *Elektroschweißung*, N° 6, 1935.

<sup>7</sup> *Röntgenographische Feinuntersuchungen an Brückentragwerken*. *Schweiz. Bauzeitung*.

<sup>8</sup> *Portevin's Method*. *Genie civil* 8/II/34, and Maybach Motor Factory, Friedrichshafen. 12/I/35. (X-ray examination of bridge girders).

sliding in one another, is placed before and after deformation with its points 1) in the holes of the member. After the points have been placed in the holes, the bars are made fast by means of the screw 5) and the distance between the measuring jaws 6) is measured with a micrometer. After a little practice,

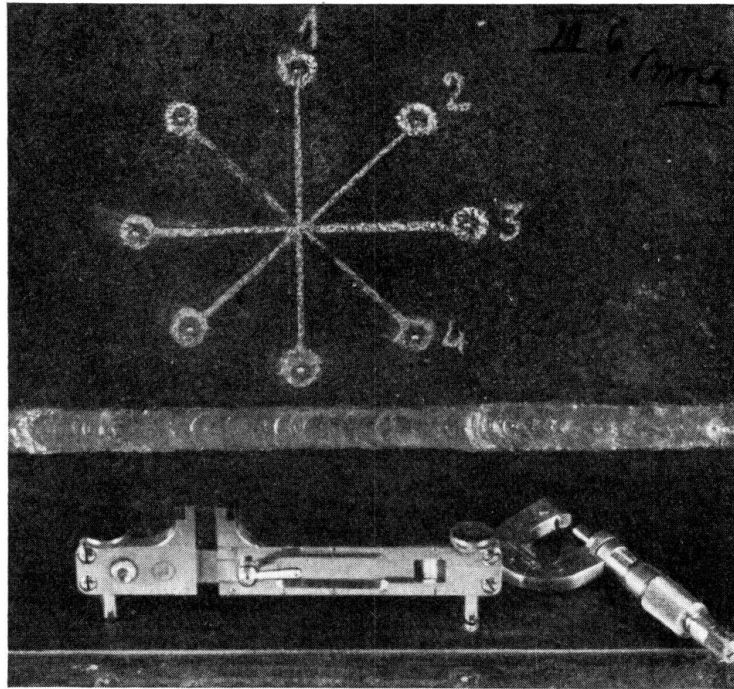

Fig. 2.

Extensometer system Meyer.

measurements to within  $\pm 1$  to 2 thousandths of a millimeter can be made. To avoid errors in testing, the use of graduated dials was purposely abandoned. For the testing of the extensometer a gauge bar is used. The small borings can be kept in condition in a simple way and for a long period by greasing them well and covering them with adhesive tape.

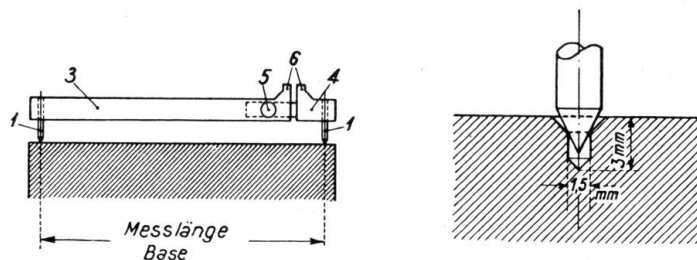

Fig. 3.

Details for taking measurements with the extensometer.

## II. Measurements Carried Out.

### 1) *Welding Plates on to Rolled Girders.*

Two heavy girders N $\approx$  100 DIN carrying the plain concrete decking of the 20 m span underbridge of the Rue Voltaire in Geneva and in each of which the

bottom flange had to be strengthened by a  $260 \times 20$  mm plate were measured at different places for deformations. The test was carried out in 1929.

It was revealed that the top flange not directly influenced by the welding was stressed at five sections to  $\pm 90$  kg/cm<sup>2</sup>. From this it was deduced that a force of about 70 tons must be exerted along both the welded joints, i. e. in consequence of the heat developed in carrying out the fillet weld and the subsequent shrinkage, the weld and neighbouring material was so shortened that between this disturbed and the upper undisturbed zone a disturbing force of 35 tons was set up at each weld. (Fig. 4.)

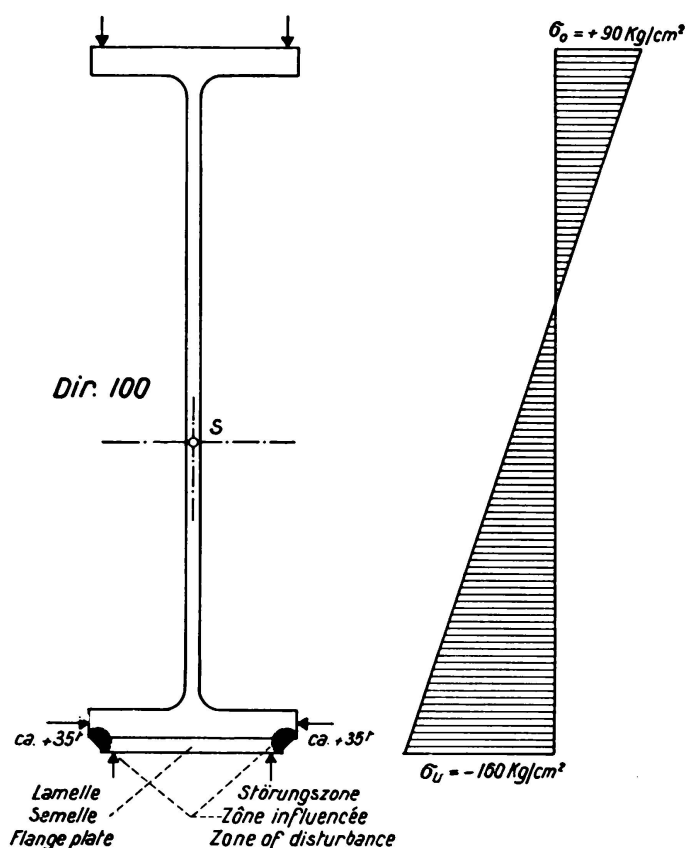

Fig. 4.

Zones of deterioration on girders of the overbridge over Rue Voltaire in Geneva.

It is clear that in this way the disturbed zone is subjected to very high tensile stress and therefore easily broken during fatigue tests. This may cause the premature breakdown of the whole girder.

The expansion measurements in the neighbourhood of the fillet welds revealed average compression stresses of  $160$  kg/cm<sup>2</sup>, which likewise approximated to a disturbing force of  $2 \times 35$  tons. It is, however, not quite certain whether the measurements taken in the case of the fillet welds do not already fall in the disturbed zone itself, whereby the values for compression stresses recorded would have to be considered as too small<sup>9</sup>.

<sup>9</sup> Bierelt: Tests for the determination of shrinkage stresses in butt welded connections. Paper read before the special committee for welding technique. V. D. I. 1934.

Measurements with thermo-elements at the girders and plates when carrying out the first pass of the fillet weld indicate the temperature gradient shown in Fig. 5, from which the intense local heat action is to be seen.

## .2) *Manufacture of a Plate Girder Railway Bridge.*

When the first welded plate girder railway bridge was being erected on the Beinwil-Reinach line in 1934, several measurements were carried out in the workshop to ascertain the shrinkage stresses. In different sections the deformations were determined after the execution of the fillet welds (Fig. 6).

It can be deduced from the measurements that the disturbing force may have a magnitude of from 30 to 40 tons, since the extreme fibre stress of the flange plates ( $-350 \times 45$ ) and ( $-350 \times 30$ ) allow the assumption of a range of mean stress of from 200 to 450 kg/cm<sup>2</sup>. In the web plate no uniform distri-

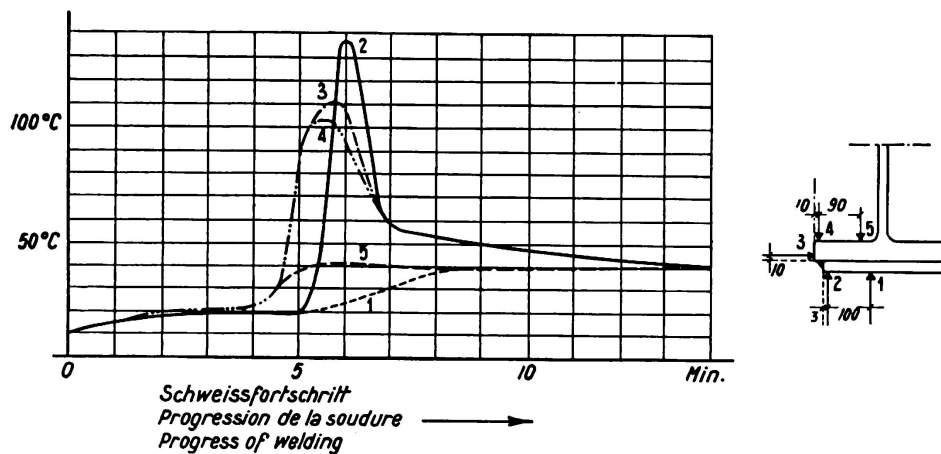

Fig. 5.

Measurements taken with Thermo-elements on the girders of overbridge over Rue Voltaire in Geneva.

bution of the deformations could be determined. This is in a measure accounted for in that the flow of heat in welding is chiefly restricted to the flange plates and only a small part is transferred to the web. Apart from this reason, the relatively thin web plate is easily distorted by considerable bending. Nevertheless, this sets up, where no influence is exerted by welding in other places, distinctly high local compressive stresses (up to 1700 kg/cm<sup>2</sup>). Measurements indicate a shortening throughout the girder of about .022 cm/m, which corresponds to

a stress of  $\frac{0.022}{100} \times 2150000 = 430 \text{ kg/cm}^2$ . In a signal-cabin bridge a shrinkage ratio of even  $10/100$  could be determined, which corresponds to a mean girder stress of 2150 kg/cm<sup>2</sup>.

In the disturbed zone the tensile stresses set up to maintain equilibrium with the compressive stresses are naturally raised to a high value. If this zone is estimated at about 20 to 25 cm<sup>2</sup>, then the welded joint and the surrounding material is stressed up to and above the elastic limit. In the case of welded joints enclosed on many sides by undisturbed material, the danger of fracturing in the disturbed zone during fatigue tests may be less than in the case of edge

fillet welds. It is to this, too, that the good behaviour of welded girders of the foregoing type under fatigue tests is attributable.

3) *Strengthening a Puddled-Iron Lattice Bridge.*

While engaged on strengthening a number of similarly built puddled-iron bridges on the Brunig route (Lucerne-Interlaken) in 1934 (Fig. 7) we set ourselves the task of determining approximately how welding affected the existing members of the structure. For this purpose measurements taken at

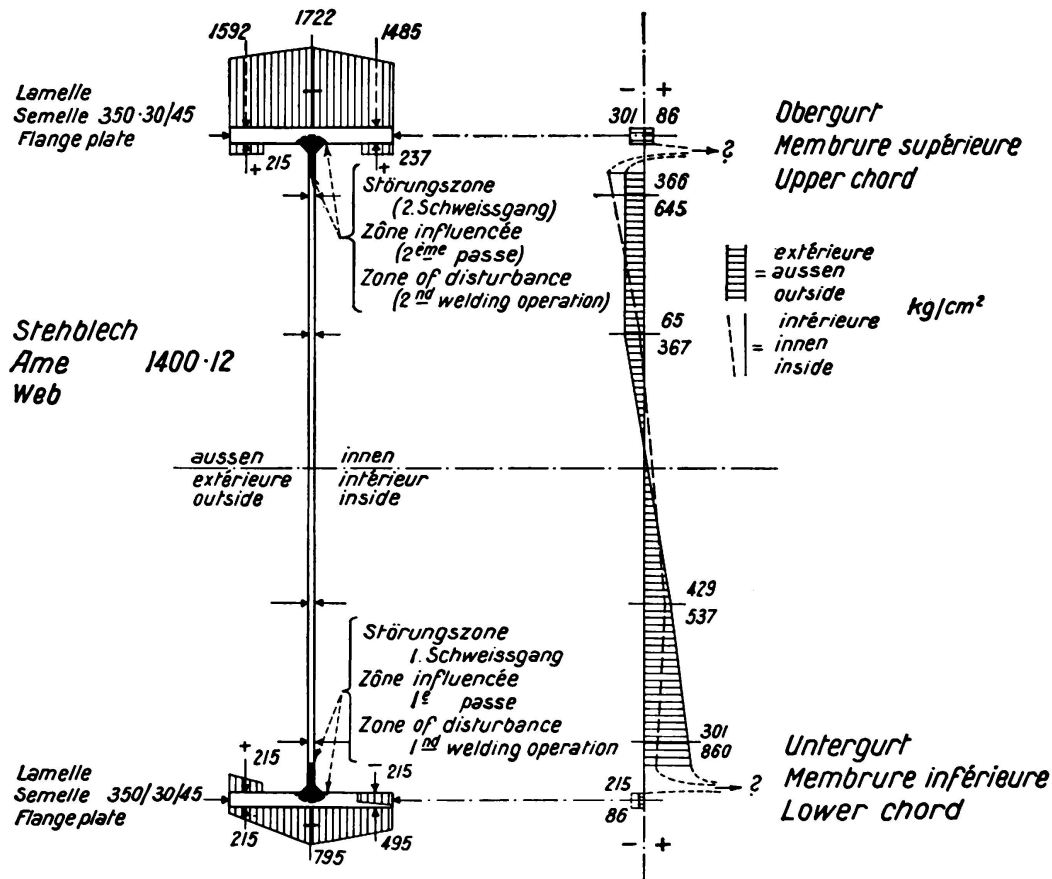

Fig. 6.

Measurements of shrinkage stresses taken on a plate girder bridge on the Beinwil-Reinach Rly-line (results of one section).

particular spots were repeated five months after welding to ascertain whether the frequently predicted equalisation of the disturbing forces is realised under traffic.

First of all, to investigate the shrinkage stresses caused by the welding on of strengthening pieces, measurements for these stresses were taken at the upper chord, bottom chord and cross bracings of three bays and at two posts. At the end of each of these bars three or four measuring places were established, distributed over the old cross section.

Measurements were not carried out at the new strengthening pieces, it being considered that these additional pieces are submitted to high stresses when being fitted, which could not be eliminated. It has nevertheless turned out that it would



have been a fruitful source of information if such measurements on the added material had been referred to.

The measurements (Fig. 7) indicate that in consequence of the shortening of the bars due to welding and through the statically indeterminate arrangement of the lattice work, also those bars were stressed which were not welded. The average stress at the centre of gravity determined from both end sections amounted to:—

		Measurements		
		1st.	2nd.*	
Top chord . . .	0-I	— 47	— 113	} non-strengthened members
Bottom chord . . .	0-1	— 40	— 75	
Tie bar . . . . .	0-1	+ 84	+ 133	
Tie bar . . . . .	II-3	+ 221	+ 265	
Post . . . . .	1-I	— 304	— 250	
Post . . . . .	2-II	— 461	— 380	

In the case of the unstrengthened members (as also for the strengthened ones) the stress curves are extremely involved. According to the diagrams the chord members and the posts are under compressions and the tie bars are subjected to tension. The highest extreme fibre stress of the bars was 840 kg/cm<sup>2</sup>.

In the case of the strengthened members of the structure the distorting forces from the deformations cannot be calculated with any degree of accuracy. The measurements show, however, that also in these bars considerable shrinkage and bending stresses were produced. The average stresses at centre of gravity amount to about (mean of the two end sections):—

		Measurements			
		1st.	2nd.*		
	Top chord . . .	II - III	— 127	— 82	} strengthened members
	Top chord . . .	VI—V	— 300	— 162	
	Bottom chord . . .	2-3	— 165	— 220	
	Bottom chord . . .	4-5	— 152	— 150	
Estimated values	Compression member . . .	0-I	— 400	— 400	
	do. . . . .	2-III	— 500	— 500	
	do. . . . .	4 - V	— 500	— 500	
	Bar with alter- nating stress	IV-5	— 600	— 600	

After being five months in service, the deformations were re-measured (\* second measurement). That alterations had taken place is rendered evident both by the decreases and the increases in the stresses.

A rule cannot be deduced from the figures obtained. It would seem to be too premature to express hopes that in the course of time an equalisation of stresses in the disturbed zones may take place.

#### 4) *Manufacture of a Curved, Plate Girder Railway Bridge.*

In the year 1936 a plate girder bridge of 27 m skew span of welded construction was installed at Baden-Oberstadt in which the sleepers rest directly on

the web plated main girders. The bridge was calculated as a three-dimensional structure under consideration of the skew, on which account the top and bottom wind bracings had to be extremely strong. At the pointed ends of the superstructure negative bearing reactions occurred, so that anchorages were necessary.

In one bay of a main girder centre marks were arranged, and after the welding of the fillet joints between flanges and web plate, the deformation of the web plate and some elongations at the web and flange plates were measured (Figs. 8 and 9). The results were as follows:—

In both flanges compressive stresses were set up and these were actually less in the first welded bottom flange. They averaged  $325 \text{ kg/cm}^2$ , being relieved by

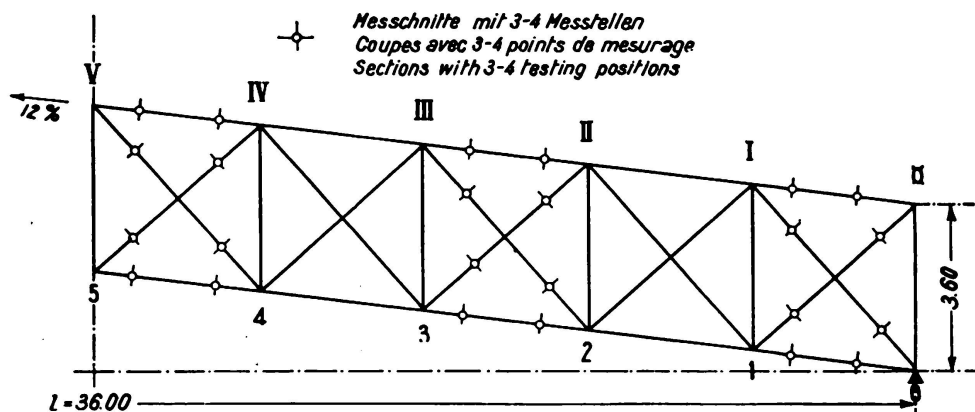

Fig. 7.

Line-diagram and positions of measurements of a puddle iron bridge on the Brünig-line.

the welding on of the top flange. The latter sustained an average stress of about  $675 \text{ kg/cm}^2$ .

The web plate likewise indicated unexpectedly high stresses ranging up to  $950 \text{ kg/cm}^2$ .

The welding of the flange plates to the web evolved very bad results. At first the gusset plates for wind bracings were welded to the flange plates and after this followed the welding of the flange plate to the web plate. As the wind bracings were riveted, the gusset connections were correspondingly drilled. A close examination showed that some of these gussets revealed cracks which passed through the holes. The deformation measurements taken revealed a distinct eccentric action on the gusset plates, accompanied by considerable tensile stresses.

As regards the deformations of web plate, they turned out to be considerable, which is not surprising in view of the stresses mentioned. The greatest deviation amounted to 2.9 mm near the first welded bottom flange. In this condition the other edge of the web plate was only partly held in position by spot welds.

The shrinkage stresses in the flange in this case were also high, because not only one welded joint, but three, are provided at each flange, bringing into play three disturbance zones, which set up tensile forces (due to shrinkage) and at the same time introduced considerable compression in the girder.

5) Views on Comprehensive Measurements.

From the none too favourable results of the foregoing, briefly discussed measurements, there can be no doubt that for a clear conception of the heat

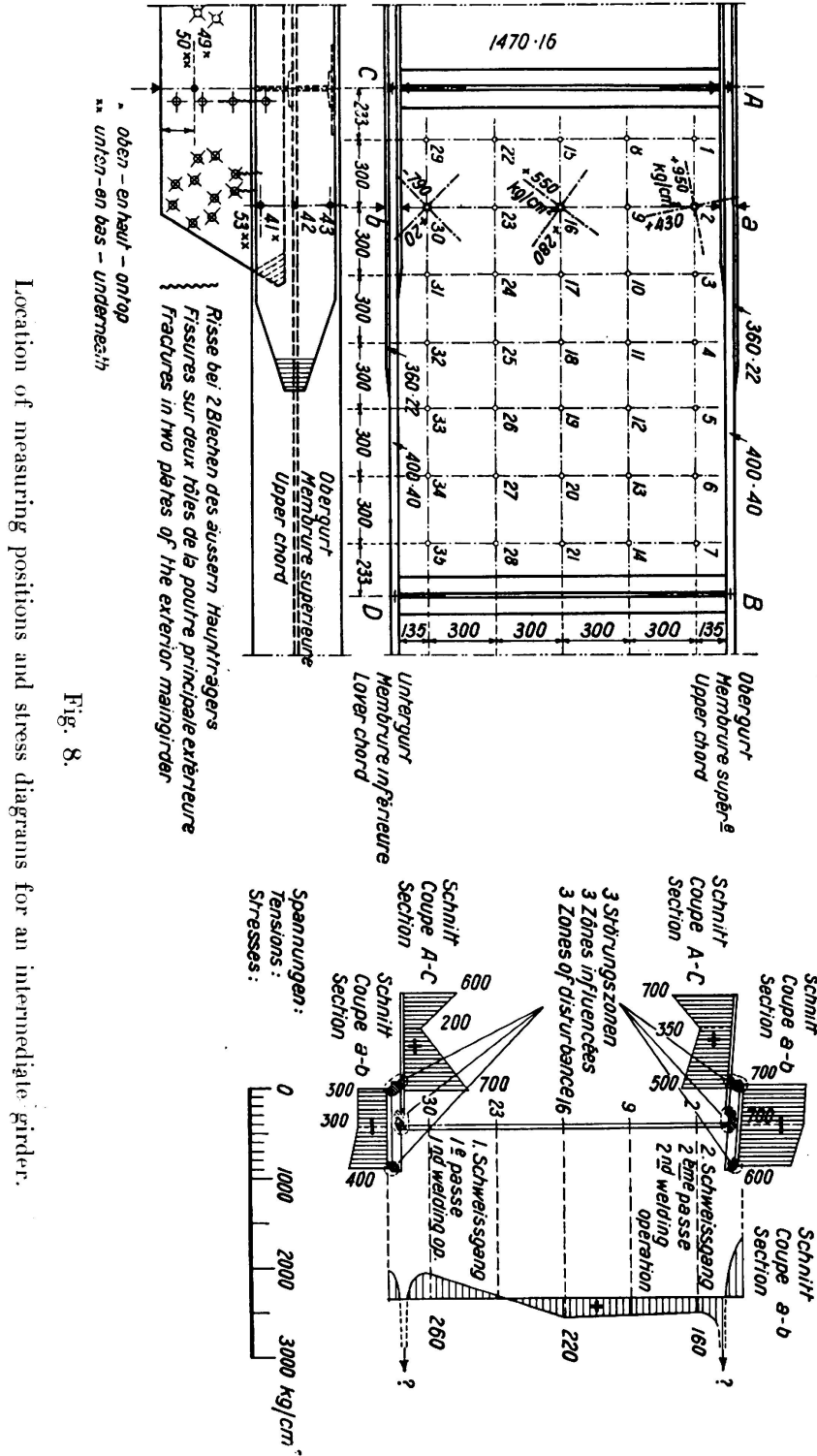

Location of measuring positions and stress diagrams for an intermediate girder.

question and also of shrinkage stresses, much more should be done than hitherto. The stresses produced by welding are extremely high and can under certain conditions of dynamically highly stressed structures, endanger the safety of a structure.

For the design of welded structures it is of great importance to possess reliable, exact results of systematic measurements of the heat and shrinkage stresses of different sections, girders and the like, so that even when designing an idea can be formed of the additional stresses set up by welding. It would be most practicable to examine in the first place the deformations of unevenly heated or undercooled flat irons as data for testing the action upon such bars of various-sized welding joints placed symmetrically and unsymmetrically.

In conjunction with this would come the examination of flat bars of various cross sections and connected by longitudinal welds; finally, built-up sections

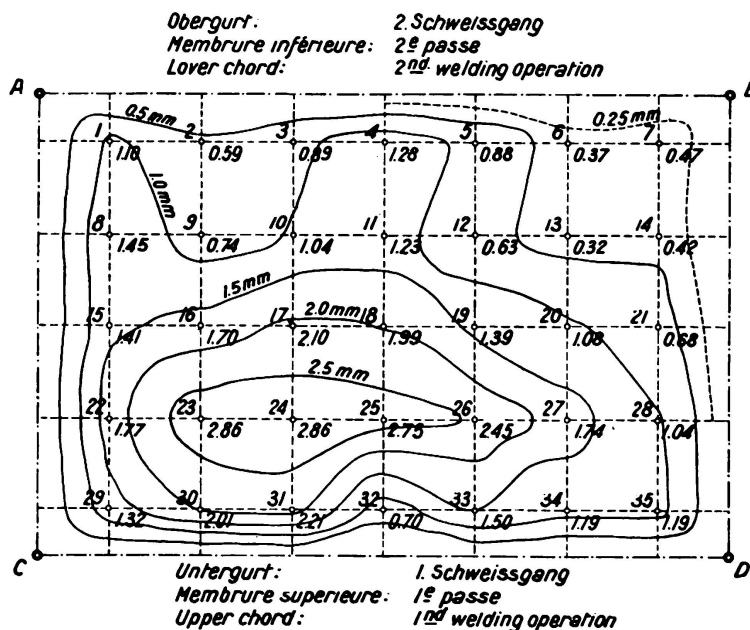

Fig. 9.

Shrinkage stresses as developed by the fabrication of curved plate girder rly-bridge. Deformation of web plate (curves of iso-flexure).

such as girders, and bars with and without stiffeners, should be examined. The greatest attention should be devoted to the exact determination of the zones of disturbances.

In my opinion, extremely valuable results could thus be obtained which would test contradictory statements as to whether it is best to weld with thick or thin electrodes, and which procedure must be given preference when welding. Where it is not necessary to render test pieces unserviceable during the test itself, these should subsequently be statically and dynamically tested.

### III. Detailing of Welded Structures<sup>10</sup>.

#### 1) Statical Strength and Fatigue Strength of the Welded Members of Structures.

It will be well remembered from the introduction and subsequent hotly-debated development in the manufacture of welded structures, that the grade of

<sup>10</sup> Die elektrische Schweißung im schweiz. Stahlbau (Electric welding in structural steelwork in Switzerland). Intern. Congress for structural steelwork, Liege 1930. Ossature métallique, N° 11, 1935.

an electrode should have been the more highly esteemed, the higher the results yielded by the usual tensile tests. At the present time most electrodes, by suitable butt-welding, reach the same ultimate strength as the material of the structure, in the case of static tests, or even more according to the shape of the test piece. It has become more a question of the shape of the test piece, what ultimate strength should be developed.

When the dynamic strength of welded joints was investigated and made known, a more sober attitude was assumed when judging the actual facts. It soon became manifest that not only the weld metal may be an essential factor for ultimate strength, but just as much the arrangement (butt and fillet welds, magnitude and intensity of the disturbance zone), the execution (thin, thick electrodes, pitting), and shape (convex, even or concave welds) of a welded joint. The co-relation of these three points of view is however still too little appreciated. The cause of this may be found in the publications relating to tests in which the above conditions were not given, so that their influence cannot be estimated.

Finally, it is a moot point whether welding wire could not be found whose composition promotes a more favourable transition zone at the weld than hitherto, and would prevent pitting.

In spite of the publication of a large number of test results it is difficult, if not impossible, to give the Wöhler curves for the different stress limits and modes of stressing from which the curves of permissible stresses can be deduced by the well-known 'Goodman' diagram<sup>11</sup>. Moreover, these stress diagrams will differ according to the number of alternations of the load before fracture; the shape of the cross section also exerts an influence in this connection.

Whilst from two to three million alternations in the main girders of large bridges are equivalent to a fairly long period of service, this number is small for the decking members, so that a great deal more should be ascertained in this connection than has hitherto been done. The Material Testing Institutions would find it well worth while to carry out basic tests, systematically and on a common programme, so that the fundamental strength of material could be thoroughly determined. It would not be necessary, in addition to butt-weld tests, to test cross joints as well as side or end fillets on covered joints, as these are not suitable for tension joints and, in practice, should not be used for such purposes. It would be much more desirable to test models of complete members of a structure, i. e. the shapes actually used. For this purpose the test piece should be so dimensioned that the ultimate strength of the material, as required in practice, may be reliably determined (such as tension, compression, shear, bending, torsion, influence of the shape of the cross section). At the same time the quality of the welding work must be exactly determined.

It may here be remarked that an examination of the welds is required, not only as to their use as joints and connections, but also their effect and the influence of their size and shape upon the through members in the case of transmission forces, as for example posts of plate girders, gussets for wind bracing,

---

<sup>11</sup> *Dustin*: Considérations sur l'endurance des assemblages soudés, Revue universelle des Mines, December 1935.

and so forth. In the broadest sense of the word, the extremely important factor of form coefficient should be determined<sup>12</sup>.

In order to show that, for example, cross joints for the transmission of tension are not bad merely because the weld has not been carried out properly, we have had tests made to prove this point, and in addition tested similarly formed test pieces worked up from solid plate. Whilst the statical tests of the welded pieces turned out to be somewhat worse than in the case of a one-piece test bar, the difference was not apparent in the pulsator machine, which proves that this type of connection is fundamentally unsuitable for service under tension<sup>13</sup>. The same could be shown for corresponding test pieces with covered joints having end and side fillets, as is often specified in regulations for decisive tests.

## 2) Type of Welds.

In order to throw light on the above-mentioned questions, we have for some years been studying the influence of the shape of the weld upon the strength of the connections and bars. To supplement the expositions made in the foregoing paragraphs, we have carried out trials upon the *influence of the position and the shape of fillet welds on structural steel 37 in the case of stiffeners, ribs, etc.*

The programme of testing was decided upon in June 1934. It provided for the examination, using unjointed flats of 15 mm thickness, of the influence of fillet welds and stiffenings as they occur when webs are reinforced, on through members, taking the following three cases of stiffening arrangements and shapes of welds (Fig. 10).

Keeping to the exact shape of weld presented some difficulty. To be able to compare results of tests, some welds had to be machined. After a few preliminary tests, tension fatigue tests under repeated loading between  $P$  and  $\frac{P}{2}$  were carried out (surge load tests). — Test reports of April 14th. 1936.

In the fatigue tests in the region of ultimate strength (surge load strength) with repeated loading, the surface cracked by fatigue was 50 to 80%; between  $P$  and  $\frac{P}{2}$  at most 50%.

From the diagram of the limiting values in the system  $\sigma_0/\sigma_u$  the ultimate surge load strength revealed in the through bars for about one million repetitions of load: —

Type of weld	I (even)	. . . . .	15 kg/mm <sup>2</sup>
	II (concave)	. . . . .	17 kg/mm <sup>2</sup>
	III (convex)	. . . . .	13 kg/mm <sup>2</sup> (preliminary test)

With the subsequent grinding of type II, the ultimate strength increased somewhat, so that the second value for this shape may be taken. The conclusions from these tests are as follows: —

<sup>12</sup> Thum: Zur Frage der Formziffer, Z. V. d. I., 26. 10. 35.

<sup>13</sup> The test reports refer to the legs of the welded fillet. Statical tests 22 to 26 kg/cm<sup>2</sup>;  $\frac{P}{2}/P$  14 kg/mm<sup>2</sup>;  $0/P$  10 kg/mm<sup>2</sup>. Test Report 25. 4. 34.

The fatigue fracture constantly originates at the transition between weld metal and parent metal. It proved to be insignificant whether the fillet welds are exactly opposite or are displaced. The shape of the stiffening has no appreciable effect.

As causes of the considerable fall in ultimate strength of through bars are to be mentioned:— deflection of the stress lines, concentration of stresses at the surface where the weld deposit begins, pitting coinciding with the same spots, changes in the internal structure of the metal and, finally, shrinkage stresses.

The fatigue strength of structural steel 37 is considerably influenced by the shape of the superimposed welds. The gradual transition from weld to plate

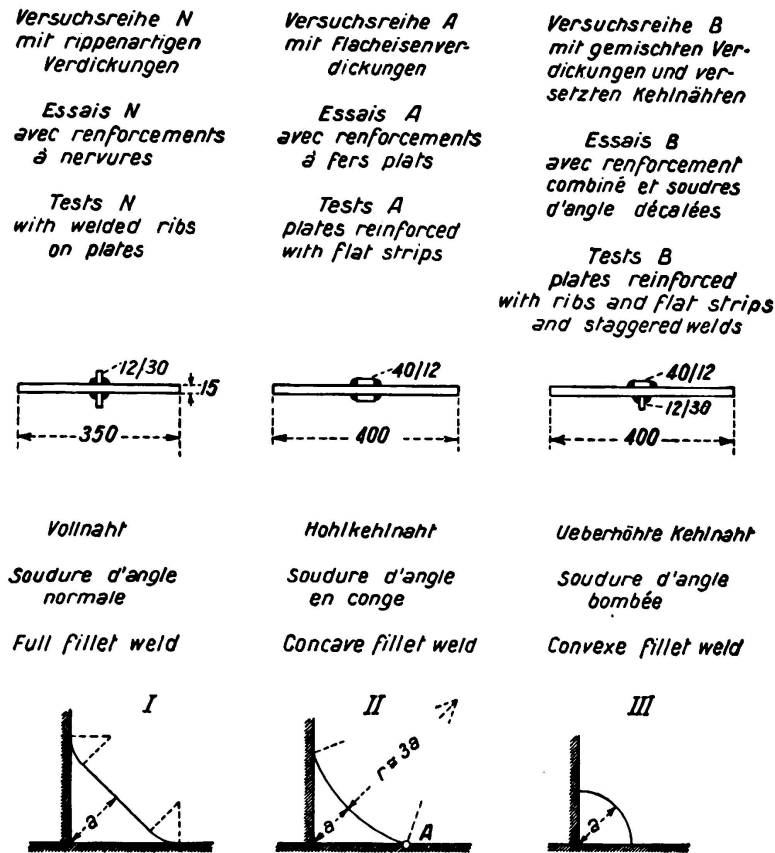

Fig. 10.

Strengthening arrangements and shape of welds applied to un-jointed plates.

causes the least disturbance. By grinding of the transition from weld metal to plate the fatigue strength is further improved. In the case of dynamically stressed members, convex fillets must be unconditionally avoided.

As long as suitable shapes of weld cannot be discovered, it must be taken into account that the surge-load strength of one-piece members subjected to tension is reduced to 15 kg/mm<sup>2</sup> in the region of superimposed welds, and only reaches .7 to .8 times the value of drilled bars in riveted connections. With a goof form of such welds the surge-load strength may attain that of a good butt weld (16 to 18 kg/mm<sup>2</sup>). The great influence of a superimposed weld on a member is thus shown and emphasizes the importance of obtaining the form coefficients.

In another series of tests a concave fillet proved to be better than a much thicker convex weld, so that here also the influence of the shape of the fillet is rendered evident. Undercut fillets with 25 to 40% less volume reveal a strength not much below that of the full normal fillet.

### 3) *Application of Welds.*

It may now be looked upon as certain that in welded structures the ultimate fatigue strength is considerably lower locally in consequence of the shrinkage stresses, pitting and changes in the texture of the material due to inroad of the weld metal. Additional material thus becomes necessary. It is therefore well to divide the uses of welding into classes in accordance with the importance of the fatigue strength, the classes could correspond to the following range of uses, namely: structural work, road bridges, railway bridges.

Structural works are in general little subjected to dynamic influence, except of course where cranes, machines and suchlike exert oscillations and vibrations. Road bridges are more severely subjected to fatigue, as the effect of lorries is becoming more and more apparent. Next in order come railway bridges, where the rapidity and magnitude of alternating stresses are predominant.

Though in the Swiss Federal Regulations of the year 1935 these differences are overcome by placing the loads and their impact as far as possible on a common basis with regard to the permissible stress, it cannot be overlooked that the period in which the repetition of loads reaches a critical number is not revealed, and that in the highest class, the railway bridges, welding must be most carefully executed and the best welds and shape chosen. It is not admissible deliberately to sacrifice the margin which must be provided for safety on the plea of cheapness and 'common practice'. The ultimate proportions given to a structure afford no proof of the margin of safety. The safety can be completely inadequate without signs of weakness becoming apparent to those concerned.

The space available does not admit of dealing exhaustively with the question of structural details. The author has set out data concerning this question in the publication mentioned at foot<sup>14</sup>.

The basic principles to be considered should be somewhat as follows: —

- a) To leave no means untried of reducing the welds and diminishing their cross section.
- b) Concentration of heat and shrinkage stresses is to be avoided by preventing the convergence of several welds; the welds should be as far as possible surrounded by undisturbed material.
- c) Endeavour to arrange for butt welded joints and to place them at positions of slight stresses. A careful selection of materials should make it possible to avoid unfavourable influences on welding by frequent flaws at the surface and edges of rolled sections (splinters, fissures, rolling skins).

---

<sup>14</sup> Die Schweiß- und Schneidverfahren im Stahlbau auf dem Gebiete des Eisenbahnwesens. (Welding and cutting methods in structural steelwork as applied for railway systems). Chapter on Structures and Bridge-building. Report for the Acetylene Congress, London, 1936.



- d) Should a connection have to be made at right angles to the applied force (longitudinal beams to cross girders, cross girders to main girders, wind bracing to flanges, etc.) no abrupt transitions should be left. The corners are to be well rounded off and the welds carefully tooled at the transition to the parent metal.
- e) Unwelded sections at the bottom of a weld are to be avoided; instead of fillet welds, K-shaped welds are recommended which admit of a through weld.
- f) As with riveting, eccentric connections are to be avoided.
- g) The simultaneous use of rivet and weld connections should be avoided, because for this special rules must first be established, especially in view of fatigue.
- h) Shrinkage in the case of butt welds amounts to 1 to 2 mm, and in the case of girders in bending with stiffeners ranges up to 1<sup>0</sup>/<sub>00</sub>.

In the erection of the structure these processes must be carefully supervised so as to eliminate additional coercive stresses.

#### IV. Manufacture of Welded Structures.

##### 1) *General.*

In the manufacture of welded structures it is frequently believed that, in comparison with riveting, the procedure is simple and will not involve a difficult change-over either as regards the workers or the workshop appliances. In high-class welding, as required for structures submitted to heavy dynamic stresses, this idea is fallacious. Calculating and designing, marking and fitting, etc., do not as a rule involve less work if the technical procedure is properly carried out. It is further to be emphasized that welded structures should be calculated as three-dimensional, since they do not possess that property of a riveted structure which relieves the load on an endangered member by the yielding of the connecting rivets. However, the best rules should also be adhered to for welding work on which the dynamic stresses are not important, on the one hand with a view to educating the personnel, and on the other because of the fact that welding should always be executed with great care on account of its unfavourable contingencies.

##### 2) *Supervision of Welding Equipment, Examination of Electrodes.*

If a welded structure is to be decided upon, the trouble of inspecting the welding plant of a workshop in which the work is to be undertaken should not be shirked. For this purpose an electrical engineer should be detailed who is acquainted with the functions and capacity of the welding apparatus (conductors, cables, transformers, earths, switches) under different loadings. It is important for the welder to have at his disposal, safely and conveniently, the right current strength, so that he can maintain the welding wire sufficiently and uniformly molten. It would appear practicable only to engage such workshops for important welding work whose electrical appliances withstand a severe test and afford proof that their welding apparatus is maintained in perfect working order.

Further it is important that the respective workshop possesses the necessary

cranes and tipping devices for the structural parts so that the welds can always be effected in the most favourable positions and the best forms obtained.

At the site, overhead welding is to be restricted as much as possible to the closing of V-shaped welds.

A further step towards securing skilful welding work is the *inspection of electrodes and welding wire when purchased*. It can of course be asserted that welding wire may be looked upon as mass production and uniformity therefore guaranteed. Yet mistakes are always possible, and on this account a point should be made of inspecting the welding wire when it is supplied, i. e. of testing the exactness of its dimensions and covering and to examine it as regards quality and technical properties. Delivery should only be accepted when the material has stood the tests.

A complete examination should be made of, say, every 10,000 electrodes or a corresponding length of welding wire. In workshops where various types of weld wire are used great care has always to be taken that the prescribed makes are used in every case. Only efficient and orderly workshop administration can guarantee satisfaction in this respect.

### 3) *Examination of Welders.*

A great deal has already been written on the testing of welders. We are of opinion that it is not much use putting them through a few of the usual practical tests. However, these tests have to be carried through both for formal and for practical reasons. For, in the first place, a certain standard of workmanship must be attained by the welder, and secondly they are likely to be impressed by the incentive of having to pass tests or execute difficult pieces of work on trial. The quality of the welding work would also be favourably influenced if the welders were given detailed instructions and explanations, both before and during execution of the job, by an experienced specialist who would also have to supervise their work. Often not even the most rudimentary instructions are given to the welders. More should be done than hitherto as regards the theoretical and practical training of the workmen. The institution of a training school for welders would be an excellent means of ensuring a supply of good, reliable craftsmen.

### 4) *Examination of the Welded Work.*

As regards the examination of welded work, the best and most dependable method known is that of X-ray photography. The other methods, such as the electro-magnetic and acoustic, are unreliable. Boring and cutting out test pieces only yields local results without permitting conclusions to be drawn as to the average quality of the work as a whole. A combination of the X-ray and cutting out methods gives the best results. This system, however, involves a good deal of time and expense, and the mending of the holes bored may cause very severe additional stresses. For butt welds the use of X-rays yields very satisfactory results in the hands of an experienced operator. Fillet and other forms of weld reveal difficulties in photographing because the thickness of the steel varies considerably as a rule. And finally the great drawback of the X-ray method alone lies in the fact that as yet no generally recognised relationship has been

ascertained between the X-ray photograph and the strength of the weld<sup>15</sup>. Thus, at present the only advantage that can be attributed to X-ray photographs is their instructive influence on the welder, as the worst errors are indicated without cutting into the welded seam — a fact that is conducive to careful workmanship. Unfortunately, the X-ray method is expensive and on that account a complete X-raying of all welds is impracticable, at any rate in structural steel-work as we know it today<sup>16</sup>.

So welding remains in the truest sense of the word a work in which the reliability of the welder counts for everything. No pressure should therefore be brought to bear on welders doing important work with a view to speeding up its execution. So-called piece-work should be dispensed with. In the case of structures subjected to considerable dynamic stress, the greatest importance should be placed upon the thorough execution of the roots of a weld, which makes it necessary carefully to open and clean roots that are first welded on one side. It is absolutely essential to examine and pass the work at these individual stages. The detection of cracks, flaws and discrepancies in the finished weld is greatly facilitated by the sand blast. This method of cleaning is to be recommended.

## V. Summary.

1) In the foregoing report, after a short introduction on the nature of heat and shrinkage stresses, a device for their measurement is described. In conjunction herewith, reference is made to the influence and importance of the disturbed zones caused by welding, which can lead to fracture from static loading or premature fatigue. Further, the results of measurements taken on four structures are cited.

2) The measurements show that the heat stresses and the shrinkage stresses arising from them are extremely important. The precautions to be taken against them consist in the diminution of the cross section of the welds and the avoidance of converging welds.

3) The disturbed zones set up by welding and their reaction on the members of a structure are insufficiently investigated. Systematic examinations are urgently desirable of the disturbed zones themselves and the influence upon them of the type of current, composition of the electrodes, diameter of the electrodes (current intensity) and the cross sections of the structural members.

<sup>15</sup> A special test with K-welds revealed an ultimate surge-load strength of  
 14—16 kg/mm<sup>2</sup> for careful workmanship,  
 12—14 kg/mm<sup>2</sup> for good workmanship,  
 9—11 kg/mm<sup>2</sup> for bad workmanship.

In comparing X-ray photos these graduations are clearly recognised but not in an absolutely convincing manner.

<sup>16</sup> Eng. *N. Record*, 15. 11. 34. In building the power-house at the Boulder Dam all welds were illuminated and X-rayed in the 45 000 ton pressure pipes (length of weld about 120 km). The results were assessed on the basis of the A. S. M. E. boiler code radiographs.

*The Engineer*, 19. 4. 35. Pullin: Radiography in the Welding Art.

4) There seems little prospect that the shrinkage stresses, as is often asserted, will vanish in time through the action of the working load, unless an otherwise undesirable condition of overstressing should arise, which may result in disquieting deformations or even cracks.

5) The art of specialising the forms of welded structures lies in the most practical realisation of the ultimate fatigue strength of steel, i. e. in the choice of suitable welds and structural details, so that the effect of pitting as well as abrupt transitions are avoided. Disturbance zones should not lie on the most stressed fibres and should be surrounded by undisturbed material. The need for keeping to a definite form of weld makes it desirable under certain circumstances to grind the weld. The smooth welds thus obtained are in any case necessary for durable painting and simple maintenance, as well as for the purpose of recognising cracks.

6) One cannot be too cautious when manufacturing welded structures; the idea that the old, traditional riveting can be replaced by *cheap* welding, is untenable. Welding, being a far more complicated process than riveting, necessitates, if it is to be successful, constant supervision both in the workshop and at site. This testing takes time, and may require the cooperation of trained specialists. For exact work marking of the weld cannot be avoided.

7) But there is more to be done besides testing welders and their work. Care must be taken that working conditions prevail that in themselves are conducive to perfect workmanship. For instance, the electrodes, the whole welding outfit and the welder's equipment must be examined and passed. The importance of the welders' work must be impressed upon them; they must be under the constant control and supervision of an expert.

8) Only when these conditions are fulfilled will it be possible to appreciate undisturbed the great advantages offered by welded structures. It may be hoped that these remarks will act as an incentive towards examining once more all questions to which the introduction of welding has given rise.

Leere Seite  
Blank page  
Page vide