

# Interpretation of tests of the equilibrium load method

Autor(en): **Stüssi, F.**

Objektyp: **Article**

Zeitschrift: **IABSE congress report = Rapport du congrès AIPC = IVBH  
Kongressbericht**

Band (Jahr): **2 (1936)**

PDF erstellt am: **21.07.2024**

Persistenter Link: <https://doi.org/10.5169/seals-3246>

## **Nutzungsbedingungen**

Die ETH-Bibliothek ist Anbieterin der digitalisierten Zeitschriften. Sie besitzt keine Urheberrechte an den Inhalten der Zeitschriften. Die Rechte liegen in der Regel bei den Herausgebern.

Die auf der Plattform e-periodica veröffentlichten Dokumente stehen für nicht-kommerzielle Zwecke in Lehre und Forschung sowie für die private Nutzung frei zur Verfügung. Einzelne Dateien oder Ausdrucke aus diesem Angebot können zusammen mit diesen Nutzungsbedingungen und den korrekten Herkunftsbezeichnungen weitergegeben werden.

Das Veröffentlichen von Bildern in Print- und Online-Publikationen ist nur mit vorheriger Genehmigung der Rechteinhaber erlaubt. Die systematische Speicherung von Teilen des elektronischen Angebots auf anderen Servern bedarf ebenfalls des schriftlichen Einverständnisses der Rechteinhaber.

## **Haftungsausschluss**

Alle Angaben erfolgen ohne Gewähr für Vollständigkeit oder Richtigkeit. Es wird keine Haftung übernommen für Schäden durch die Verwendung von Informationen aus diesem Online-Angebot oder durch das Fehlen von Informationen. Dies gilt auch für Inhalte Dritter, die über dieses Angebot zugänglich sind.

## Interpretation of Tests of the Equilibrium Load Method.

### Zur Auswertung von Versuchen über das Traglastverfahren.

L'interprétation des essais sur la méthode de l'équilibre plastique.

Privatdozent Dr. F. Stüssi,

Berat. Ing., Zürich.

Prof. *Maier-Leibnitz*, in his contribution to the Preliminary Report of the Congress,<sup>1</sup> has collected and interpreted the results of the experiments on the equilibrium load method already made known through the technical press. These experiments include some recent work by Prof. *Maier-Leibnitz* himself<sup>2</sup> with which the present writer now proposes briefly to amplify. This work, in agreement with the author's experiments at Zürich,<sup>3</sup> does not show any complete assimilation of the moments in the span and over the supports.

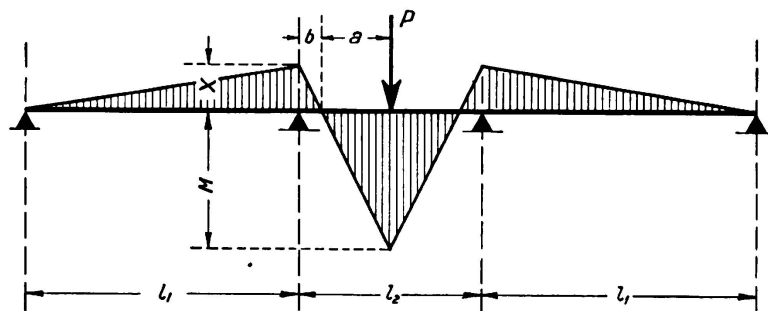

Fig. 1.

Arrangement of test.

In the case of a continuous girder as shown in Fig. 1, the conditions of equilibrium and of elasticity derived from static practice must hold good even as regards the non-elastic region, and, in particular, the bending moment line must continue across any intermediate support. If  $A$  denotes the total angular

<sup>1</sup> *H. Maier-Leibnitz*: Versuche, Ausdeutung und Anwendung der Ergebnisse. I.A.B.S.E., Second Congress Berlin 1936, Preliminary Report.

<sup>2</sup> *H. Maier-Leibnitz*: Versuche zur weiteren Klärung der Frage der tatsächlichen Tragfähigkeit durchlaufender Träger aus Baustahl. „Stahlbau“, (1936), No. 20.

<sup>3</sup> *F. Stüssi* and *C. F. Kollbrunner*: Beitrag zum Traglastverfahren. „Bautechnik“, (1935), No. 21.

rotation in a simple beam of span  $l = 1$  loaded to correspond with a triangular bending moment diagram  $M$ , and if  $B$  denotes the greater angle of rotation over a support, then the condition of elasticity may be written as

$$B_X \cdot l_1 = A_M \cdot a - A_X \cdot b. \tag{1}$$

If, as in the present case (Fig. 2), the variation in moment as the load increases is found by observation, then from Equation (1) the unknown  $A_M$  may be calculated. The values  $A_x$  and  $B_x$  are known in the elastic region, and for higher increments of loads they may be derived successively from the values of  $A_M$

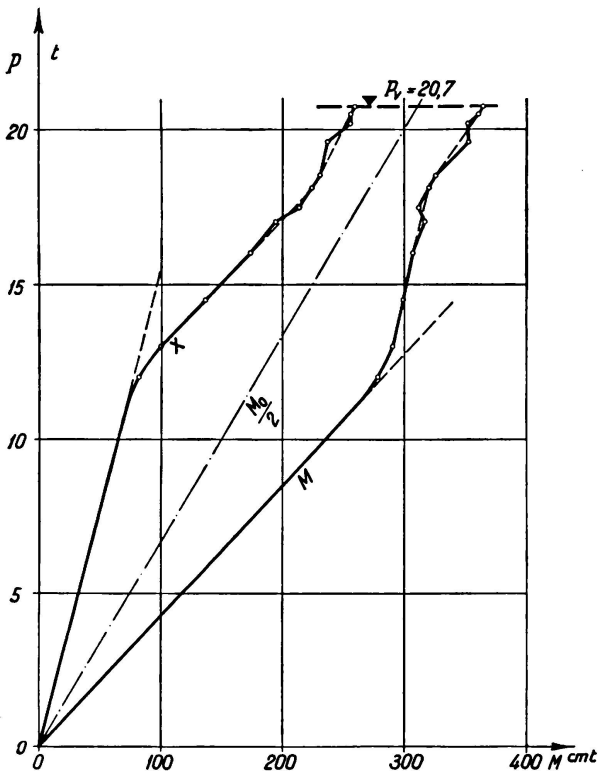

Fig. 2.

Variation of moments.

Experiments by Prof. Dr. Maier-Leibnitz.

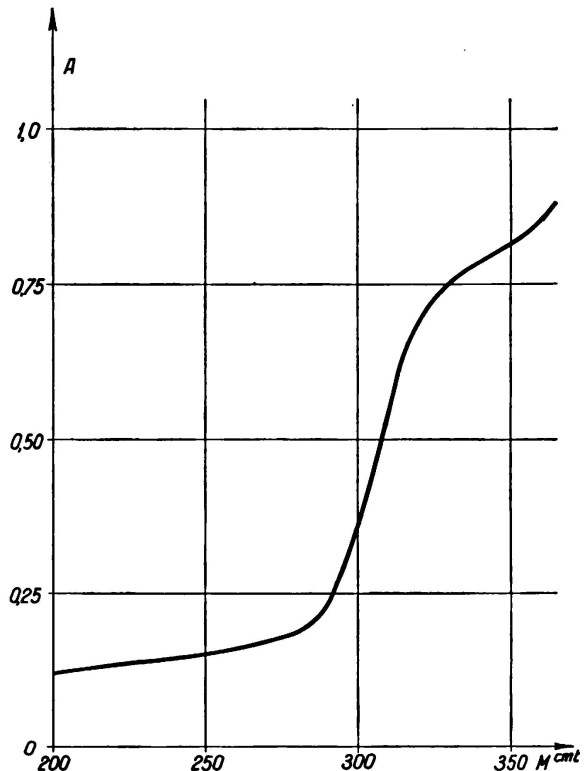

Fig. 3.

Total angular rotation  $A$ .

which correspond to smaller loads. Fig. 3 shows the variation in the total angular rotation  $A$  as calculated in this way: it will be observed that there is a clearly marked increase in the bending moments above approximately 315 cm-tonnes, that is to say in the zone which could no longer be observed in the comparative experiment with the simple beam.

In this way, a single experiment allows the coefficients to be determined, enabling the variation in moment to be calculated with the help of the elastic condition of Equation (1) also for other conditions of span.

If it be desired to draw from this some conclusion as to the variation in carrying capacity, one more assumption must be made, namely, that in all cases the limit of carrying capacity will be reached when the maximum bending moment occurring under load attains to a particular limiting value. This

assumption is plausible enough in itself, for unless it is justified the whole method of calculation of stresses underlying constructional practice must be invalid. The first consequence of this assumption is that we may derive from the elementary conditions of equilibrium existing in the central span, a comparison between the carrying capacity of the continuous girder ( $P$ ) and that of the simply supported beam ( $P_0$ ), namely

$$P : P_0 = (M + X) : M \quad (2)$$

Since, however, these experiments by Prof. *Maier-Leibnitz* again indicate no complete equalisation of moment, the carrying capacity of the continuous girder is not double that of a simply supported beam. A continuous beam calculated in

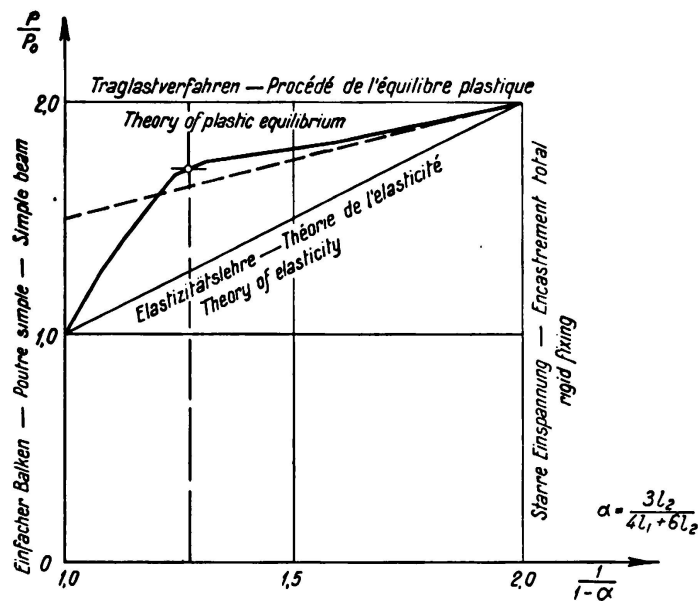

Fig. 4.

Calculated carrying capacities.

accordance with the equilibrium load method therefore possesses a smaller factor of safety against the attainment of the limiting load than is possessed by a simple beam.

Fig. 4 also shows the calculated relationship between the carrying capacities. The trend of this curve agrees broadly with that determined in the author's earlier experiments, and except in abnormal cases where the side spans are very large these values still lie somewhat above those indicated by a straight line (shown broken) which halves the difference between the equilibrium load method and the theory of elasticity. The proposal made by the present writer is, therefore, that the increase in carrying capacity of continuous beams of structural steel as calculated by the equilibrium load method, by comparison with the theory of elasticity, should be utilised, if at all, only to the extent of one half; and further, that this utilisation of the increase in factor of safety should be confined for the present to rolled joists as used in building construction.