

Long span reinforced concrete arch bridges

Autor(en): **Hawranek, A.**

Objektyp: **Article**

Zeitschrift: **IABSE congress report = Rapport du congrès AIPC = IVBH
Kongressbericht**

Band (Jahr): **2 (1936)**

PDF erstellt am: **21.07.2024**

Persistenter Link: <https://doi.org/10.5169/seals-3307>

Nutzungsbedingungen

Die ETH-Bibliothek ist Anbieterin der digitalisierten Zeitschriften. Sie besitzt keine Urheberrechte an den Inhalten der Zeitschriften. Die Rechte liegen in der Regel bei den Herausgebern.

Die auf der Plattform e-periodica veröffentlichten Dokumente stehen für nicht-kommerzielle Zwecke in Lehre und Forschung sowie für die private Nutzung frei zur Verfügung. Einzelne Dateien oder Ausdrucke aus diesem Angebot können zusammen mit diesen Nutzungsbedingungen und den korrekten Herkunftsbezeichnungen weitergegeben werden.

Das Veröffentlichen von Bildern in Print- und Online-Publikationen ist nur mit vorheriger Genehmigung der Rechteinhaber erlaubt. Die systematische Speicherung von Teilen des elektronischen Angebots auf anderen Servern bedarf ebenfalls des schriftlichen Einverständnisses der Rechteinhaber.

Haftungsausschluss

Alle Angaben erfolgen ohne Gewähr für Vollständigkeit oder Richtigkeit. Es wird keine Haftung übernommen für Schäden durch die Verwendung von Informationen aus diesem Online-Angebot oder durch das Fehlen von Informationen. Dies gilt auch für Inhalte Dritter, die über dieses Angebot zugänglich sind.

IVb 7

Long Span Reinforced Concrete Arch Bridges.

Weitgespannte Eisenbeton-Bogenbrücken.

Ponts en arc de béton armé à grande portée.

Dr. Ing. A. Hawranek,

ord. Professor an der Deutschen Technischen Hochschule, Brünn.

The author's paper on "Long Span Reinforced Concrete Arch Bridges" had reference firstly to new and more exact calculations making use of different moduli of elasticity at different points in the arch; secondly to the theory of deformations arising under variable values of E and I , and thirdly to the case of an arch in which the line of thrust is prescribed and of which only the final results are stated. Apart from this, suggestions relating to materials were considered, followed by others as to the construction of large arches, the necessary falsework and the constructional details, which may promote the development of large reinforced concrete bridges. Finally a proposal was made for a new method of constructing large arched bridges. In the contribution to the discussion which follows below some amplifications of this last question will be put forward; also numerical calculations to show the application of the theoretical treatment, and misprints in the Preliminary Report will be pointed out.

I. Theoretical investigation. Results of numerical calculations made in accordance with the theory explained in the preliminary report.

1) *Application of varying moduli of elasticity to a hollow cross section.*
Elastic theory.

The treatment of varying moduli of elasticity in arch bridges of hollow cross section (Point 3, page 789 in the Preliminary Report) can be stated in a more general way than was done in the Preliminary Report. A difference was assumed between the modulus of elasticity E_1 and E_2 for the concrete in the lower and upper slabs of the hollow cross section respectively, but these moduli were assumed to be constant through the whole length of the arch. It is possible, however, to assume varying values of E_1 and E_2 at different cross sections of the arch, somewhat in accordance with the progress of the constructional work which causes the concrete to be of differing age in each section. This closer analysis is also called for by the higher moments that arise in the process of striking the centreing with the aid of hydraulic jacks. (See *Hawranek*, Schweizerische Bauzeitung, 1937, Vol. 110, p. 153.)

Using the symbols indicated in Fig. 1 the moments, normal and shear forces are given by:

$$\begin{aligned}
 M_x &= \mathfrak{M}_x + M - Hy - Vx & \text{and} & & k_1 &= \frac{E_1}{E_2} + 1 \\
 N_x &= H \cos \varphi + Q_x \sin \varphi & & & k_2 &= \frac{E_1}{E_2} - 1 & k &= \frac{k_2}{k_1} \\
 Q_x &= V + \mathfrak{Q}_x = V - \sum_x^{1/2} G & & & & & &
 \end{aligned}$$

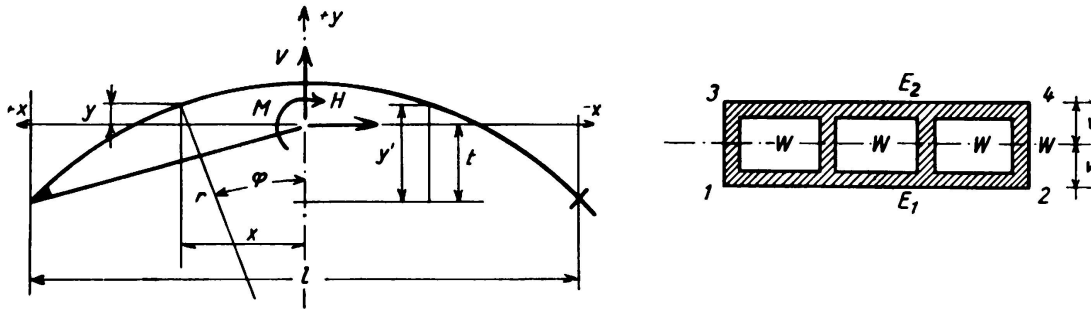

Fig. 1.

Hence we can obtain the three statically indeterminate values H, V, M and the distance t to the elastic centre of gravity:

$$\begin{aligned}
 H &= \frac{\int \frac{\mathfrak{M}_x y k_1 ds}{E_1 J} - \int \frac{\mathfrak{M}_x k_2 v \cdot ds \cdot \cos \varphi}{E_1 J} + \int \frac{\mathfrak{Q}_x y k_2 ds \sin \varphi}{v E_1 F} - \int \frac{\mathfrak{Q}_x k_1 ds \sin \varphi \cdot \cos \varphi}{E_1 F} + 2 \varepsilon t l}{\int \frac{y^2 k_1 ds}{E_1 J} - \int \frac{y k_2 v ds \cos \varphi}{E_1 J} - \int \frac{y k_2 ds \cos \varphi}{v E_1 F} + \int \frac{k_1 \cos^2 \varphi ds}{E_1 F}} \\
 V &= \frac{\int \frac{\mathfrak{M}_x x k_1 ds}{E_1 J} - \int \frac{\mathfrak{M}_x k_2 v \cdot ds \cdot \sin \varphi}{E_1 J} + \int \frac{\mathfrak{Q}_x x k_2 ds \cdot \sin \varphi}{v E_1 F} - \int \frac{\mathfrak{Q}_x k_1 ds \cdot \sin^2 \varphi}{E_1 F}}{\int \frac{x^2 k_1 ds}{E_1 J} + \int \frac{k_1 ds \cdot \sin^2 \varphi}{E_1 F}} \\
 M &= \frac{\int \frac{\mathfrak{M}_x k_1 ds}{E_1 J} + \int \frac{\mathfrak{Q}_x k_2 ds \sin \varphi}{v E_1 F}}{\int \frac{k_1 ds}{E_1 J}} + H \frac{\int \frac{y k_1 ds}{E_1 J} - \int \frac{k_2 ds \cos \varphi}{v E_1 J}}{\int \frac{k_1 ds}{E_1 J}} \\
 t &= \frac{\int \frac{y' k_1 ds}{E_1 J} - \int \frac{k_2 v ds \cdot \cos \varphi}{E_1 J}}{\int \frac{k_1 ds}{E_1 J}}.
 \end{aligned}$$

According to this general theory an arch with $l = 400$ m and $f = 100$ m was worked out numerically (Preliminary Report, Fig. 5, p. 802), taking the moduli of elasticity in the soffit barrel as being $E_1 = 470\,000$ kg/cm² at the springing and $350\,000$ kg/cm² at the crown, and the corresponding figures for the upper barrel as $E_2 = 350\,000$ kg/cm² in the springing and $230\,000$ kg/cm² at the crown, with a gradual transition in between (elastic theory). These variations in value for the elasticity would correspond to the necessary period of time taken in constructing so large an arch. With loading over *one half of the arch* on the right

curve g_x is assumed to vary in accordance with $\cosh \alpha x$ corresponding to the distribution of weight in an actual arch, and account has also been taken of thermal effect and of shrinkage. In the theoretical development the value d' corresponding to the normal forces has been assumed more accurately than in the Preliminary Report.

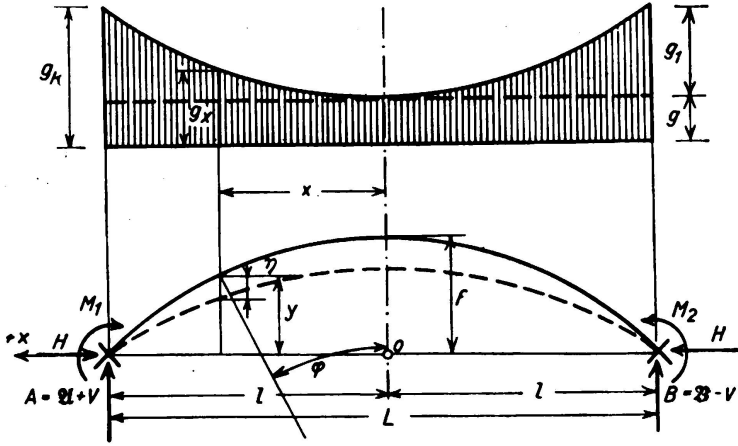

Fig. 3.

Equation for axis of arch:

$$y = f(1 + v) - fv \cosh \alpha x$$

$$v = \frac{1}{m-1}; \quad m = \frac{g_k}{g} = \cosh k$$

$$k = \text{arc cosh } m; \quad \alpha = \frac{k}{l}$$

Specific loading:

$$g_x = g \cosh \alpha x; \quad g_1 = g_k - g$$

Differential equation for line of flexure:

$$\eta'' = -\frac{M_x}{EJ' \cos \varphi} + \frac{N_x}{EF'} \cdot \frac{d^2 y}{dx^2} (1 + \cos^2 \varphi) + \frac{1}{EF'} \cdot \frac{dN_x}{dx} \cdot \frac{dy}{dx} + \epsilon t \cdot \frac{d^2 y}{dx^2}$$

with $c^2 = \frac{H}{EJ' \cos \varphi}$

$$\eta'' = -c^2 \left\{ \frac{M_x}{H} - y \left(1 + \frac{\epsilon t \alpha^2}{c^2} \right) + \frac{V_1}{H} (1-x) + \frac{M_1}{H} \right\} - c^2 \eta - c^2 \left[\frac{d' \cdot J}{F} + \frac{\epsilon t f \alpha^2 (1+v)}{c^2} \right]$$

so that $d' = fv \alpha^2 \cosh \alpha x \left[(1 + \cos^2 \varphi) + \left(1 - \frac{\dot{y}^2}{2} + \frac{3}{8} \dot{y}^4 \right) f^2 v^2 \alpha^2 \sinh^2 \alpha x \cos \varphi \right]$

$$\eta'' + c^2 \eta + c^2 F(x) = 0$$

$$M_x = \frac{g_1 v}{\alpha^2} (\cosh k - \cosh \alpha x)$$

Solution of the differential equation:

$$\eta = A \sin cx + B \cos cx - \left\{ \frac{M_x}{H} - f \cdot w [1 - v (\cosh \alpha x - 1)] + \frac{V_1}{H} (1-x) + \frac{M_1}{H} + \frac{d' J}{F} + \frac{\epsilon t f \alpha^2 (1+v)}{c^2} \right\} + \left(-\frac{g_1 v}{c^2 H} + \frac{fv w \alpha^2}{c^2} - R \right) \cosh \alpha x$$

where $w = 1 + \frac{\epsilon t \alpha^2}{c^2}$,

$$R = -\frac{\alpha^3 v}{c^2 (\alpha^2 + c^2)} \left(\frac{g_1}{\alpha H} - fw \alpha \right)$$

Under a loading g_x we obtain:

$$M_x = H \left[\frac{z}{\alpha c} \frac{\sinh k}{\sin cl} \cos cx - \frac{d' J}{F} + \left(fv - \frac{g_1 v}{\alpha^2 H} + \frac{z}{\alpha^2} \right) \cosh \alpha x \right]$$

$$M_1 = H \left[\frac{z}{\alpha c} \sinh k \cotg cl - \frac{d' J}{F} - \frac{1}{\alpha} \left(\frac{g_1 v}{H} - z \right) \cosh k \right]$$

The horizontal thrust H may be calculated by equating the sum of the horizontal compressions in the elements of the arch to zero, with $\Delta l = 0$; i. e. from the following equation:

$$0 = -\left(\frac{H}{EF' \cos \varphi} + \epsilon t \right) l - \frac{fv}{2} \left[z + \left(\frac{H}{EF' \cos \varphi} + \epsilon t \right) \cdot fv \alpha^2 \right] \cdot \left(-l + \frac{1}{\alpha} \sinh k \cosh k \right) - \frac{fv \alpha c B}{c^2 + \alpha^2} (c \sinh k \cos cl - \alpha \cosh k \cdot \sin cl).$$

The moments and the deflection were determined according to this theory for the same arch of 400 m span due to the *dead load* of the bridge itself. The curve of loading is shown in Fig. 4. It indicates 189.5 tonne/m at the springing and 99.0 tonne/m at the crown.

The moment in the springing amounts to -11041.553 tonne · m (as against -7080.942 tonne · m by the elastic theory; $\Delta = 56.0\%$) and the moment at the crown works out at $+4357.149$ tonne · m (as against 3889.062 tonne · m by the elastic theory; $\Delta = 12.1\%$).

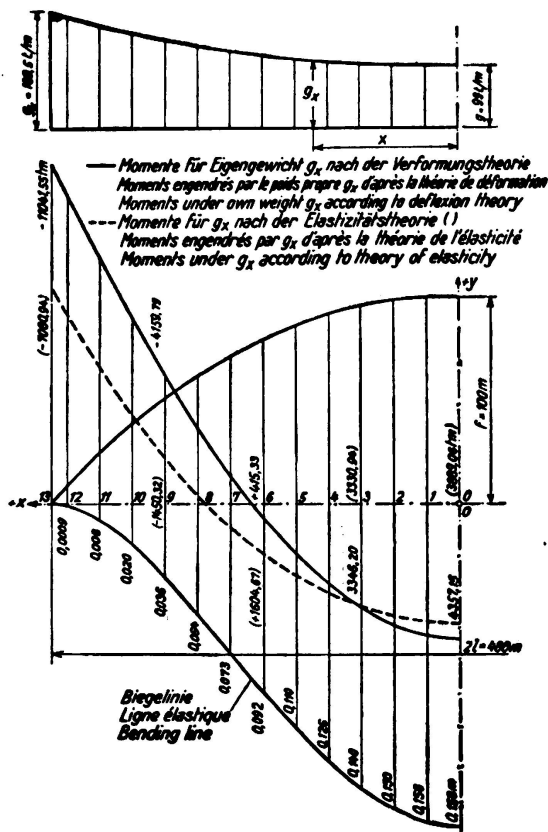

Fig. 4.

Moments and bending lines under own weight according to deflection theory.

Here again considerably greater differences in the moments are obtained than those between the results of the deflection theory and the elastic theory when respectively applied to an arch with a parabolic axis, under permanent full loading. In the crown and in the springing they are larger and only in fields 3 and 6 of the span are they smaller, these fields being each one eighth of the span.

The deflection of the arch was likewise determined under the dead load of the bridge itself; and it amounted to 158 mm at the crown, which corresponds to $1/2530$ l. The deflection line is incorporated in Fig. 4.

These results also show the necessity for more exact investigation in the case of an arch with its axis along the line of thrust, since a parabolic axis does not correspond with the true conditions, especially if the rise be large.

The fixing moments at the springing of a built-in arch are always the heaviest, and, since for large spans the permissible stresses require to be increased if the

structure is to remain economical, the more exact determination of the moment is essential if excessive stresses are not to occur in practice. It is also made necessary by the use of hydraulic jacks when removing the falsework.

By the use of the formulae given in the Preliminary Report which made use of a fixed value of $d = \frac{2J}{rF_m}$, it is also possible to take account of the *varying* value of d , and this is discussed elsewhere. Numerical calculations indicate that the true value is larger and that the influence on the moments is not negligible. (Hawranek, Der Bauingenieur 1937, p. 719.)

As regards the more exact method of calculation for arch bridges (whether in steel or in reinforced concrete) by the deflection theory, it may be stated in general that nothing but numerical solutions for different forms of arch will correctly indicate the importance of the influence exerted by the various assump-

tions or the various terms in the formulae. It is necessary, therefore, that such calculations should be carried out and made available, enabling comparisons between the results of different methods of calculations. If measurements made on completed bridges are available these should be compared with theory, and in making the comparison reliance should be placed not on the elasticity theory but on the deflection theory, taking due account of all relevant circumstances in interpreting the experimental results, for otherwise mistakes are unavoidable. This applies particularly to reinforced concrete arch bridges.

The value of making exact calculations should not be underestimated and one should not be deterred by the amount of work involved, for a clarification of the conditions is important both for the safety of these structures and for their economy. When everything has been cleared up by research a further increase in the permissible stresses may be contemplated. Further investigations might then be made as to the influence of deformation in very flat arches, as to the effect of varying relationships of live to dead load on the moment, and as to other conditions governing variations in the moments of inertia.

Among the problems, manifest to everyone, on which experimental research is still needed, is that of elucidating how the load is transferred from the roadway to the arch through the columns or by hangers; in other words the nature of the local stresses at these places when the supports are placed relatively close together or far apart. Such investigations are particularly required in relation to arches of hollow cross section.

The aspects of arch design which have been referred to above or in the original paper, and the further theoretical researches on problems of arches that are required as a step to the adoption of higher permissible stresses, are dealt with by *Boussiron*. The author's choice of an arch of *constant* cross section for a design for 400 m span is arrived at from the same considerations as are advanced by *Boussiron* in his paper.

II. Properties of materials.

The increase in the permissible compressive stress for concrete to 150—200 kg/cm², as proposed in the paper for long span bridges, should not be too difficult to justify on the basis of cube strengths. Both the German and the French engineers have expressed this opinion.

The latter already contemplate permissible stresses in the concrete of 150 kg/cm² with 1% reinforcement, or even of 240 kg/cm² with 3.6% of hooping, where the ultimate strength of the concrete is 450 kg/cm². As regards the use of hooping further experiments are, however, still required on specimens with a flat rectangular cross section, reinforced by spirals *close together* after the manner frequently adopted in the case of hollow sections.

As regards the effect of these arrangements of spirals as compared with spirally bound columns, opinions differ, and the advocacy of particularly high permissible stresses in the concrete in hooped hollow sections of this kind is therefore to be received with caution, quite apart from the difficulties in concreting that are inherent in this type of reinforcement. If the ultimate compressive strength of concrete is brought to up to about 700 kg/cm² then hooping may not be required.

As regards the *physical* properties of the concrete, further investigation is desirable, as these exert a particularly marked effect on all reinforced concrete arch bridges. Here the coefficient of *thermal expansion* of the concrete plays a part. Usually this is taken to be of the same value as for the steel, but since the true value for pure cement is considerably higher than for the aggregate (and since, moreover, it differs according to the source of the cement) the value for the concrete must depend on the mixture. According to the experiments of S. L. Meyers¹ on cement, the coefficient of thermal expansion also increases with age. In the case of high silicate cements the increase is quite considerable, but in that of high lime cements it is only small, even after several months. In the first mentioned case, after nine months, it amounts to almost double the initial value. If it were found that the same phenomenon held good for European cements it would be necessary to take this into account. In the actual concrete the effect will, of course, be considerably less, but it is nevertheless present. So far as is known the coefficient of thermal expansion of concrete is lower than that of the steel, varying around 0.000009 for 1° C in the former compared with 0.00001234 in the latter. This difference gives rise to stresses in both materials, and therefore to moments in the arch.

Another question is that of the *heat of setting* which reaches its maximum after 15 to 20 hours and causes increases in temperature of 40 to 60° C. In test cubes the temperature again becomes equal to that of the air after about two days have elapsed, but according to experiments on bridges by C. R. Whyte² the fall in temperature may take 12 to 20 days according to the position in the cross section, during which time the concrete will long ago have hardened. If the coefficients for thermal expansion differ for the concrete and the steel this will entail transfers of stress between the two materials.

Neither the differing coefficients of thermal expansion as between the concrete and the steel, nor the heat of setting will, indeed, exert much effect on arch bridges, but they do play a part in the great complex of questions relating to materials.

As regards *shrinkage* and *plastic deformation* in the concrete, a great deal has been said in the paper. The critical phenomenon of plastic deformation has not yet been fully explained, and in particular it has not yet been ascertained whether the two phenomena may influence one another; moreover the question arises whether apart from any other relationships between them heat may not also play a part. There is here a great gap in our knowledge of the properties of concrete. As regards the effect of these phenomena on reinforced concrete arch bridges, the author has elsewhere³ advanced some speculations, and has put forward a new method of calculation.

It is important in this context also to take account of *plastic* compression in the *abutments*, which undergo a permanent contraction in the direction of the load and thereby increase the span. This contraction of the abutments will be

¹ Eng. News Record, 1935/I, p. 424.

² Eng. News Record, 1936/I, p. 693.

³ A. Hawranek: Zukunftsfragen des Baues weitgespannter Eisenbeton-Bogenbrücken mit besonderer Berücksichtigung der Plastizität des Betons. Beton und Eisen 1937, N° 2.

appreciable only if they are not surrounded by subsoil water, and if the foundation blocks are of large dimensions. When hinges used in the arch are placed in a forward position the total length from the hinges to the base of the foundation should be taken into account when calculating the plastic contraction, besides that of the arch itself.

III. Pre-stressing of the reinforced bars in reinforced concrete arches.

On account of the shrinkage effect, and of that portion of the plastic strain which does not operate in a purely plastic manner, tensile stresses are set up in the concrete, and additional compressive stresses arise in the reinforcement even with purely plastic contraction. Unless these changes are neutralised by the use of hydraulic jacks in the process of striking the falsework, or in the case of small spans where this procedure is not adopted, these additional stresses can be reduced or eliminated by *pre-stressing* the reinforcing steel as already indicated in the report.

In such a case the reinforcing bars should be made continuous through the whole length of the arch, their component lengths being welded together and provided with screw turnbuckles, somewhat staggered in position along the length, for the purpose of tensioning. The round bars, embedded in the abutments over a sufficient length, must be provided with supports at intermediate points consisting either of reinforced concrete separators which have already been hardened and placed against the shuttering, or of steel frames adapted to the whole or the hollow cross sections of the arch and are supported by the shuttering, to allow of accurate and uniform placing of the steel. These intermediate members placed at intervals of 10 to 15 m are intended to transfer the compressive stresses arising from the tensioning of the steel, on to the falsework. In the case of arches of hollow cross section the intermediate diaphragm walls may be made to serve this purpose. The turnbuckle may be placed in the shrinkage gap left open in concreting, thus making it possible to adjust the stress in the section about to be concreted, after the main stressing for the whole length of the arch has been already carried out.

If it were desired to introduce a tensile stress of 1000 kg/cm^2 in the steel over a length of 100 m it would be necessary to stretch the length of the latter by 4.76 cm. Such an adjustment would tend to upset the continuous curvature of the steel bars by changing it towards a polygonal shape, and would thereby reduce the moment of inertia at the kink points and result in a varying thickness of cover, unless the intrados and extrados were made polygonal in shape. The stability of the intermediate pieces for adjusting the position of the steel bars placed near the extrados can be attained by concreting those steel frames into position.

Using this procedure it would be possible, in most cases, to adopt ordinary commercial steel.

Another method is to make use of a *rigid* form of reinforcement with provision for driving in wedges between the steel arch and the falsework so as

to obtain prestressing in the steel, but these might differ as between the upper and lower booms.

In the case of *hinged arches* the steel might be temporarily built in to the abutments, and if necessary at the crown, in order to allow of stressing, and after the concrete had been placed the steel at the hinges might be cut through.

The question whether to adopt this new method or to make use of a high quality steel without eliminating the compressive stresses must depend on the relative economy of the two proposals.

IV. Design for an arch of 400 metres span.

In the paper a new idea was put forward for constructing large span reinforced concrete arch bridges (Fig. 5, p. 802).

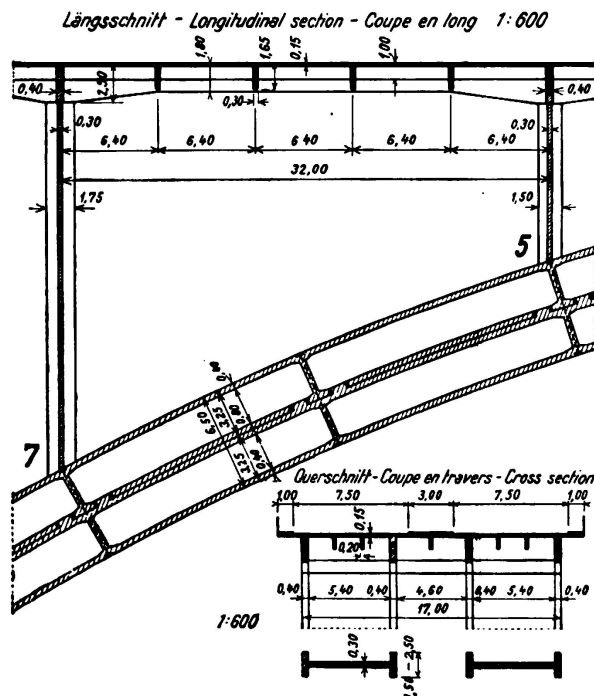

Fig. 5. Roadway construction.

The proposal consists in making the main arch double, consisting of two similar superimposed but separate arches whereof the lower one would be built on centreing and would, when finished, be released by suitable procedure in striking the falsework and adjusted at this stage by means of hydraulic jacks, using the most effective means possible to eliminate shrinkage stresses and settlement due to plastic strain. Using this first arch as centreing, the second arch would then be concreted and released in the same way. The two arches would then be connected together so as to co-operate.

A longitudinal and cross section of the roadway and of the supports are shown in Fig. 5. In what

follows below some amplifications and improvements of this proposal will be explained.

1) The connection between the two superimposed separate arches.

The main feature of the connection between the two arches as shown in Fig. 6 is the use of *dowels* which are dovetailed not only in elevation but also in cross section. This latter characteristic absolutely prevents the separation of the two arches as the grout filling in the gaps is wedge shaped and is reinforced. The wedges serve to prevent the upper arch from rising. Since these dowels are placed close to the transverse and longitudinal strengthening provided by the ribs on the concrete slabs, there is no danger that the slabs may be torn out of the arch. As a further precaution round steel anchorages passing right through both arches

are provided; these are concreted into the lower arch and project into steel pipes which are concreted into the upper arch. The play of the anchoring bar within the pipes does not interfere with the adjustment of the arches by hydraulic jacks, and when the final condition has been obtained the cavities left in the pipes can be filled with cement grout and the nuts on the end of the pipe can be tightened up.

At a later stage in the construction, when the roadway is in position, there will be no tendency for the two arches to separate from one another, and on the contrary the increasing shrinkage effect and plastic strain being larger in the

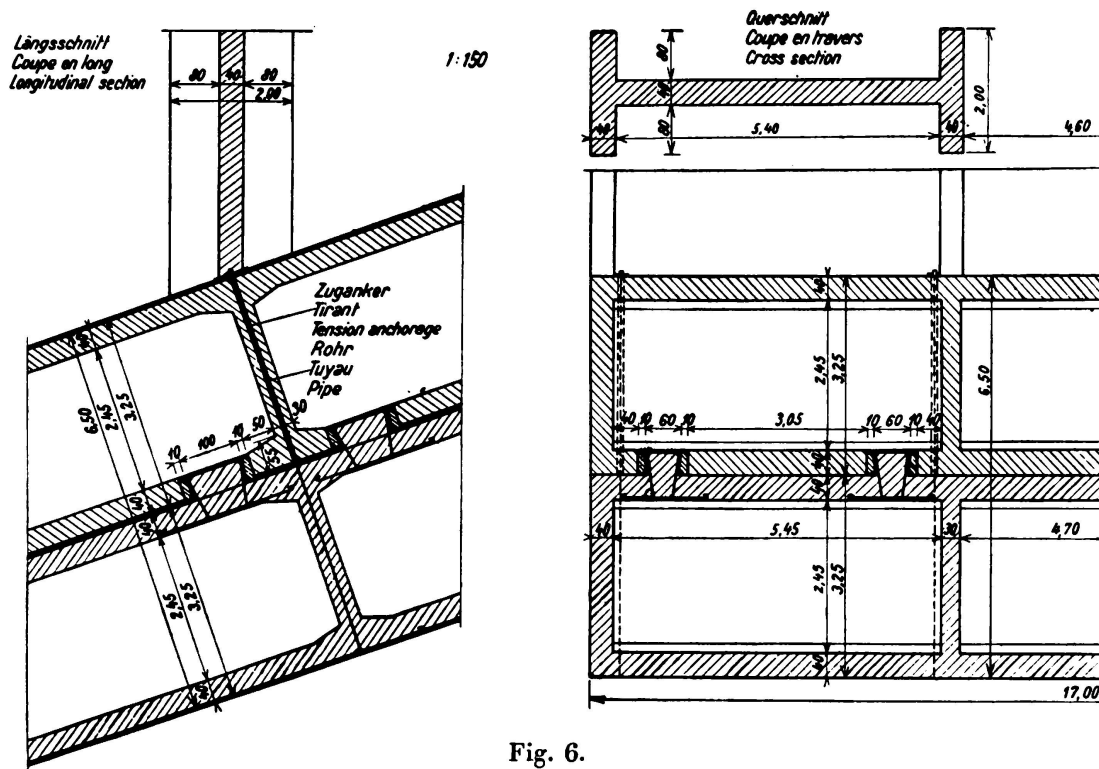

Fig. 6.
Connection of the two arches.

upper arch than in the lower arch will counteract any such tendency or may even reverse it.

This would be subject to confirmation by the fact that when load is added by constructing the roadway, or when a larger amount of shrinkage takes place in the upper arch than in the lower, the upper arch will not only be supported by the abutments but, apart from this, it can be considered as being *elastically supported* over its whole length by the lower arch. Such mutual reactions, and the additional moments produced in either arch, are susceptible to calculation.

This idea of a *compound arch* is one which admits of further elaboration, particularly as regards obtaining an increased moment of inertia in the lower arch by adding upward ribs or vertical walls which can be built into the upper arch.

Finally there is yet another possibility: the load carrying arch might be divided into two principal ribs connected by intermediate walls (provided these offered

the requisite amount of lateral resistance to buckling) and in this way a portion or the whole of the falsework could be used over again. With a moderate ratio of rise to span further advantages might be secured, mainly a saving in the cost of the falsework.

In the Preliminary Report only the principle of this solution was explained.

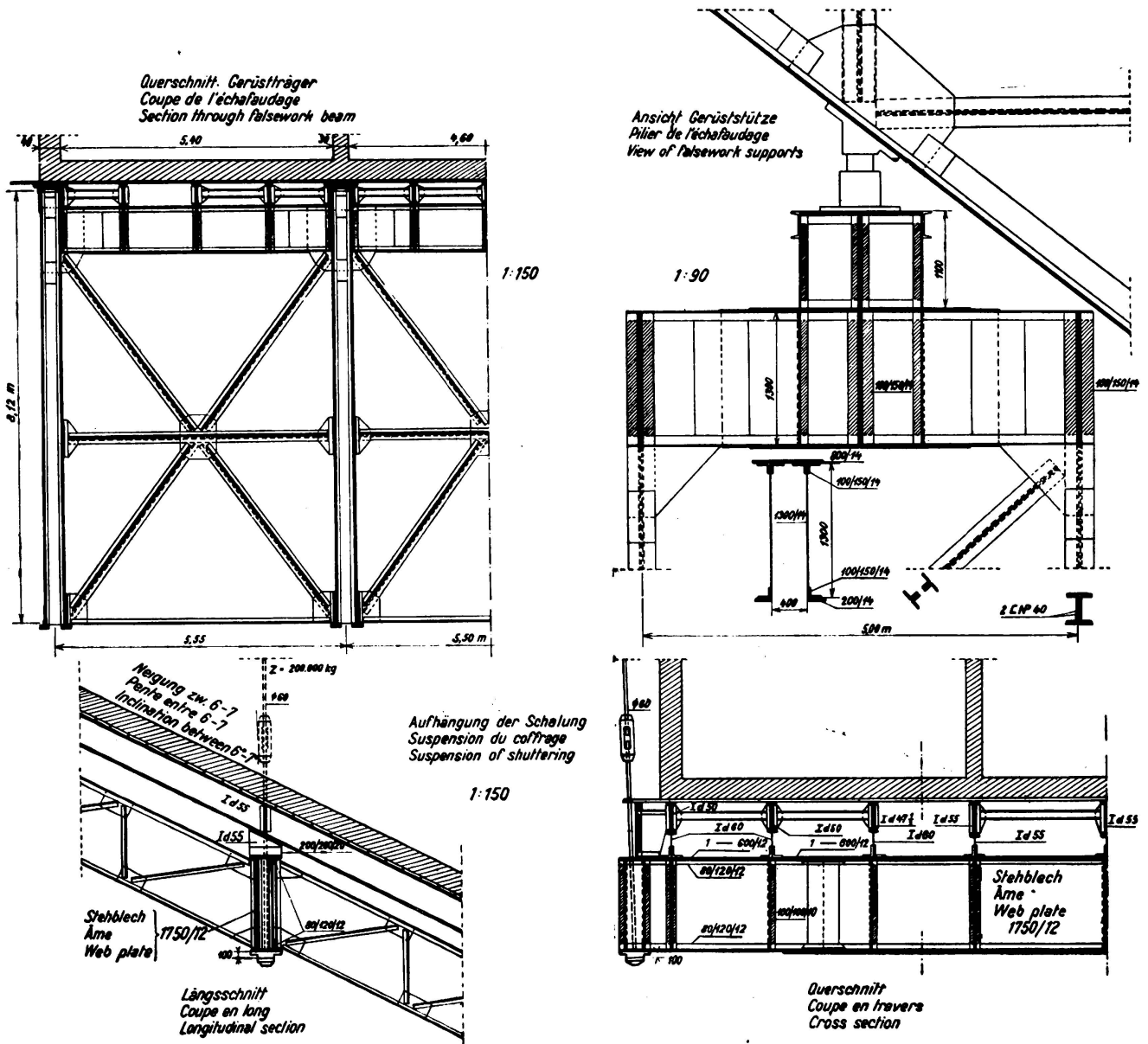

Fig. 7.

Shuttering and bracing frame.

2) Centreing and Falsework.

The falsework for the arch has been calculated and designed in detail (Fig. 7). The fixed portion consists of four main lattice trusses which are arranged underneath the vertical spandrel walls of the arch and are supported on towers through the medium of hydraulic jacks. The steel beams which serve to carry the

shuttering for the arch itself are supported on cross girders which rest in turn on the four main lattice girders, in the fixed portion of the falsework, while the cross girders in the suspended portion at their ends are carried by suspension rods from the cables. Owing to the great width of the bridge double webbed plate girders are necessary, which at their ends carry vertical lattice girders for stiffening the falsework in that direction, and which are connected by wind bracings (Fig. 8).

It would, however, be advantageous to use not two main cables but three or four of smaller size, thus enabling the cross girders and the wind bracings in the central portion of the falsework to be made much lighter on account of the

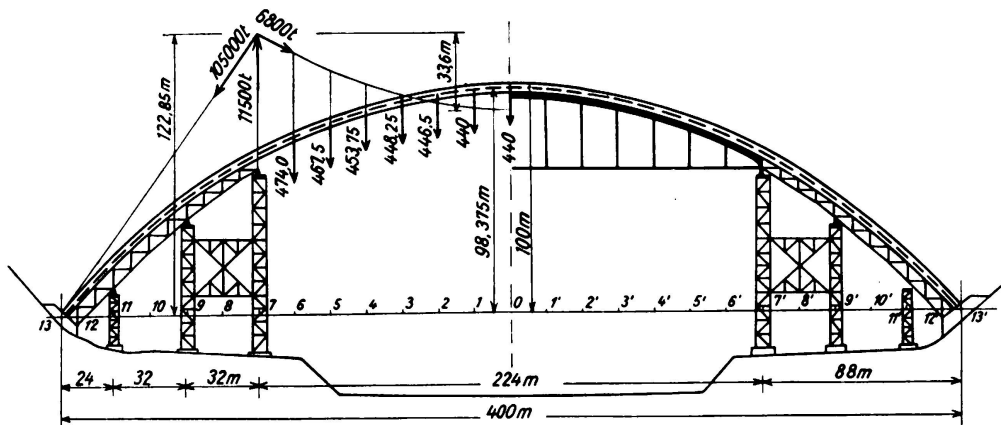

Fig. 8.
Forces in a carrying cable.

intermediate support afforded; at the same time this would be more economical since weight would also be saved in the suspension cables. The pylons could also be used to carry a cableway.

The loading of two cables for a single reinforced concrete arch with shuttering, cross girders, longitudinal girders, cable and suspension bars amounts to $g' = 55$ tonnes per metre run, which would correspond to a total pressure on the pylon of $P = 11,500$ tonnes and to a tension in the anchoring cables of $R = 10,500$ tonnes; the maximum tension in the cable over the central opening would be $S = 6,800$ tonnes. Fig. 8 shows these loads and reactions arising in one cable. With permissible stress of $7,000 \text{ kg/cm}^2$ in the cables, their cross section if only two cables are used becomes

$$f_r = 1,500 \text{ cm}^2 \text{ for the anchorage cable and}$$

$$f_s = 972 \text{ cm}^2 \text{ over the central opening.}$$

The total weight of steel in the falsework will be:

Weight of pylons	2×575 tonnes	= 1,150 tonnes
Cables and suspenders		1,100 tonnes
Fixed falsework	2×600 tonnes	= 1,200 tonnes
		3,450 tonnes.

In relation to the space filled, which is $\frac{2}{3}$ rds. $f \cdot l \cdot b = 480,000 \text{ m}^3$, the total weight of the falsework will be $3450 \text{ tonnes} / 480,000 \text{ m}^3 = 0.0072 \text{ tonnes per m}^3$.

In the case of the Traneberg bridge with a span of 181 m the weight of the falsework amounted to 948 tonnes over the total width of the bridge, which was 18 m, and the total space filled was

$$\frac{2}{3} \times 181 \times 26.2 \times 18 = 56,000 \text{ m}^3,$$

corresponding to 0.0167 tonnes per m^3 . In the present case, therefore, although the shuttering has been designed to cover the whole width of the bridge, the specific weight of steel per sq. metre is less than one half (actually 0.43) of the corresponding amount in the Traneberg bridge, and this despite the fact that in the latter case the falsework was used twice over. This is evidence of the economy of the proposal.

The total cost of the falsework may be estimated at:

$$\begin{array}{r} 2,150 \text{ tonnes a } 3,000 \text{ Czech crowns} = 6.45 \text{ million crowns} \\ 1,100 \text{ tonnes a } 5,000 \text{ Czech crowns} = 5.50 \text{ million crowns} \\ \hline K_1 = 11.95 \text{ million crowns} \end{array}$$

which compares with the following for the Traneberg bridge:

$744,000 \text{ Swedish crowns} \times 6.55 = K_2 = 4.83 \text{ million Czech crowns}$. The ratio of cost $K_2 : K_1 = 0.405$ practically corresponds with the ratio of weight which was 0.43. If the falsework girder and supports were to be used twice over a still greater saving could be realised. Re-use in this way, the sequence of work being planned accordingly, is feasible — especially if the towers are to remain in situ — but has not here been considered.

With a flat arch, instead of using *vertical* towers for the cables as here proposed, it would be possible to use pylone inclined outwards, with the advantage that the tension in the anchoring cable and in the connecting portion over the central opening could be made equal, and therefore the same cross section could be used throughout the length of the cable. Apart from this the cable saddle would be easier to design as no additional anchoring cable would be necessary and the single cable of uniform cross section would merely have to be bent over the saddle. An inclined pylon of the kind envisaged would, however, complicate the towers of the falsework, as there would have to be an inclined strut reaching to the ground below.

Finally, it would be possible instead of using the suspended construction of falsework as here proposed, to make use of a steel arch with a tie spanning across the reduced central field of 224 m, having its bearings on the towers (Fig. 8). Such an arch, to be used twice over for constructing a twin reinforced concrete arch, could be shifted from one position to the other. In a moderately small span such a lateral displacement of the steel arch with its supporting structure would be possible, and in this way considerable saving in the cost of falsework could be realised.

3) *Quantities of Material.*

In regard to the quantities required, the following volumes of concrete may be estimated:

Arch	15,650 m ³
Cross walls of arch	610 m ³
Roadway and supports	5,690 m ³
	21,950 m ³

which amounts to 0.0456 m³ of material per m³ of the space filled, not counting the abutments. The total in the design by *Dischinger* is 20,800 m³ corresponding to 0.0434 m³ of concrete per m³ of space filled.

Assuming a daily output of 100 m³ the construction of the arch would require 156 working days, or about three months for each separate arch.

For the shuttering 4,040 m³ of timber are necessary.

4) *Moments, Thrusts and Stresses.*

The statical calculations have resulted in the moments and normal forces given in Tables 1 and 2, the live load assumed on the bridge for the purpose of designing the arch being taken as 6 tonnes per metre run, and the range of temperature $\pm 15^{\circ}$ C, with shrinkage reckoned for $- 15^{\circ}$ C. The wind pressure is taken as 250 kg/m².

Table 1.
Moments in tonne-m.

	Point 0 (crown)	3	6	9	13 (springing)
Dead load of roadway and columns (without arch)	- 13260	- 240	+ 4520	+ 10860	- 21960
Live load on one half p = 6 tonnes per m	+ 8090	- 7234	+ 8306 - 8506	+ 1604 - 2908	- 12554 left + 14804 right
Thermal effect $\pm 15^{\circ}$ C E = 210,000 kg per cm ²	\mp 1920		\mp 746		\pm 3420
Shrinkage - 15 ^o C	+ 1920		+ 746		- 3420
Σ 1-4	- 14776				- 41354
Wind moment: bending	\pm 10780		\pm 937		+ 53723
Wind moment: torsion	0		\pm 3522		\pm 3295

Table 2.
Normal forces in tonnes (compression —).

	Point 0 (crown)	3	6	9	13 (springing)
Dead load of a single arch alone	— 8760	— 9000	— 9780	— 10730	— 12800
Dead load of roadway and columns	— 5367	— 5544	— 5818	— 7050	— 8400
Live load on one half p = 6 tonnes per m	— 608	— 604 — 644	— 694 — 649	— 862 — 629	— 1125 — 600
Thermal effect ± 15° C	± 53.3		± 48.7		± 35.9
Shrinkage — 15° C	+ 53.3		+ 48.7		+ 35.9

With these moments and normal forces the maximum stresses work out as shown in Table 3 for points 0, 6 and 13 in the arch; — the dead load, live load over half the span, temperature drop of — 15° C and shrinkage for 15° C being taken into account.

Table 3.
Maximum concrete stresses in the arch (kg per sq. cm).

Point	Dead load Loading on one half Thermal stress for — 15° C Shrinkage for — 15° C	Wind 250 kg/m ²	Total unadjusted	Total adjusted by pressure H _z = 280 tonnes
0 (crown)	86.7 compression 30.5	± 9.6	96.3 compression	97.1 compression
6	92.9 39.9 compression	± 0.84	93.7 compression	106.0 compression
13 (springing)	166.1 13.1 compression	± 48.0	214.1 compression	163.4 compression

To reduce the total stress of 214.1 kg/cm² in the springing an additional force H_z must be provided at the crown, which can be effected by the use of hydraulic jacks, and the resulting moment at the springings will be

$$M_1 = H_z \cdot f = 100 H_z$$

The normal force in the springing becomes

$$N_z = H_z \cos \varphi_K = 0,672 \cdot H_z.$$

If the condition is laid down that the maximum stresses in either springing due to dead load, live load on one half of the bridge, thermal effect for — 15° C

and shrinkage — 15° C must be equal, the following equation must be satisfied, assuming concentric pressure at the crown:

$$\frac{N_1 + N_z}{F} + \frac{M_1 - H_z f}{W} = \frac{N_2 + N_z}{F} + \frac{M_2 - H_z f}{W}$$

and

$$H_z = \frac{W}{2f} \left(\frac{N_1 - N_2}{F} + \frac{M_1 - M_2}{W} \right)$$

Here N_1 , M_1 relate to the left hand springing and N_2 , M_2 to the right, on inserting the absolute values of the two springing moments as follows:

$$\begin{array}{ll} M_1 = 41,354 \text{ tonne-m} & N_1 = 35,053.2 \text{ tonnes} \\ M_2 = 13,996 \text{ tonne-m} & N_2 = 34,528.2 \text{ tonnes} \\ F = 39.1 \text{ m}^2 & W = 54 \text{ m}^4 \end{array}$$

and assuming $H_z = 280$ tonnes, the maximum concrete stresses that can ever arise are those at the springings which work out at 115.4 kg/cm^2 , or including wind $115.4 + 48 = 163.4 \text{ kg/cm}^2$, the reinforcement in the arch being only 1%. All other stresses in the arch will be lower, amounting, inclusive of wind, to 97.1 kg/cm^2 at the crown and 106 kg/cm^2 at the quarter point. Thus the effect of the pressure imposed by jacks is to reduce the maximum stress at the springings by about 30.5% without wind or by about 23.6% including wind.

A further reduction in the compressive stress of the concrete could easily be obtained by building the arch with a small lateral batter in the neighbourhood of the springings alone, this would allow the maximum stress inclusive of wind to be as now as 150 kg/cm^2 . The same effect, however, is obtainable with a thrust of $H_z = 340$ tonnes without such lateral haunching. By this means the extreme fibre stresses at the springings and at the quarter points would become equal.

This shows that a relatively slender arch of constant cross section with a maximum stress in the concrete of approximately 150 kg/cm^2 is practicable, and would necessitate only the very moderate pressure of 340 tonnes at the crown when the centreing is struck.

The new proposals for the construction of long span bridges put forward here and fully supported by calculation may, therefore, be looked upon as an acceptable method for promoting the further development of reinforced concrete arch design.