

The development of steelwork design and details, shown in heavy movable plant for lignite mining

Autor(en): **Beyer, K.**

Objektyp: **Article**

Zeitschrift: **IABSE congress report = Rapport du congrès AIPC = IVBH
Kongressbericht**

Band (Jahr): **2 (1936)**

PDF erstellt am: **21.07.2024**

Persistenter Link: <https://doi.org/10.5169/seals-3316>

Nutzungsbedingungen

Die ETH-Bibliothek ist Anbieterin der digitalisierten Zeitschriften. Sie besitzt keine Urheberrechte an den Inhalten der Zeitschriften. Die Rechte liegen in der Regel bei den Herausgebern.

Die auf der Plattform e-periodica veröffentlichten Dokumente stehen für nicht-kommerzielle Zwecke in Lehre und Forschung sowie für die private Nutzung frei zur Verfügung. Einzelne Dateien oder Ausdrucke aus diesem Angebot können zusammen mit diesen Nutzungsbedingungen und den korrekten Herkunftsbezeichnungen weitergegeben werden.

Das Veröffentlichen von Bildern in Print- und Online-Publikationen ist nur mit vorheriger Genehmigung der Rechteinhaber erlaubt. Die systematische Speicherung von Teilen des elektronischen Angebots auf anderen Servern bedarf ebenfalls des schriftlichen Einverständnisses der Rechteinhaber.

Haftungsausschluss

Alle Angaben erfolgen ohne Gewähr für Vollständigkeit oder Richtigkeit. Es wird keine Haftung übernommen für Schäden durch die Verwendung von Informationen aus diesem Online-Angebot oder durch das Fehlen von Informationen. Dies gilt auch für Inhalte Dritter, die über dieses Angebot zugänglich sind.

V 1

The Development of Steelwork Design and Details, shown in
Heavy Movable Plant for Lignite Mining.¹

Entwicklung des Stahlbaues und seiner baulichen
Einzelheiten durch den Bau der fahrbaren Großgeräte
des Braunkohlen-Bergbaues.¹

Le développement de la construction métallique montré par
la construction du grand outillage mobile des exploitations
de lignite.¹

Dr. Ing. K. Beyer,

Professor an der Technischen Hochschule Dresden.

It is the author's intention in the few minutes at his disposal to draw attention to a field of work which lies on the boundary of German structural steel engineering proper, and which owes its development to the last few years but has already attained considerable importance. The impulse for this development

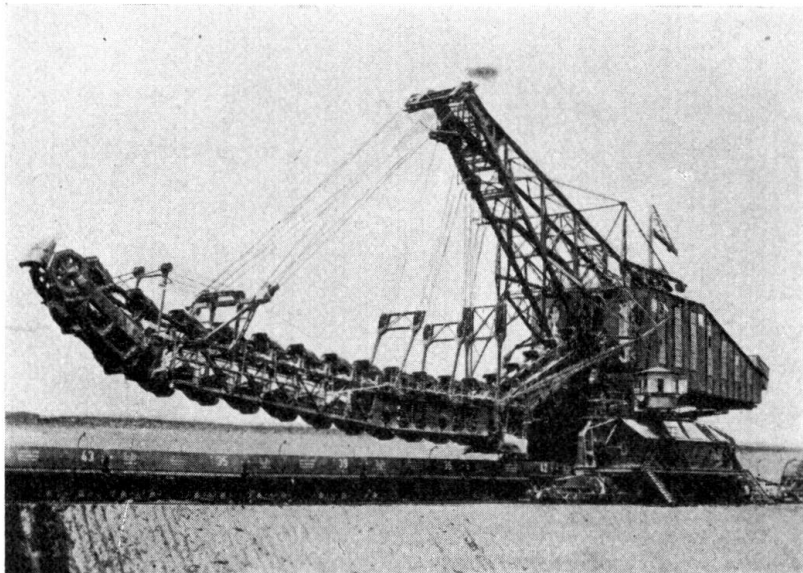

Fig. 1.

has been due to the German lignite mining. In Germany, lignite is obtained from large open casts, in seams which may be up to 60 m thick. The removal of the

¹ Extract from a longer publication to be made later.

overburden from the coal is effected by large moveable pieces of plant weighing as much as 5,000 tonnes, and the steel construction of these is in many ways similar to moveable steel bridge structures of the largest sizes. Their calculation and design has given rise to many new theoretical and constructional problems to which brief reference will be made here.

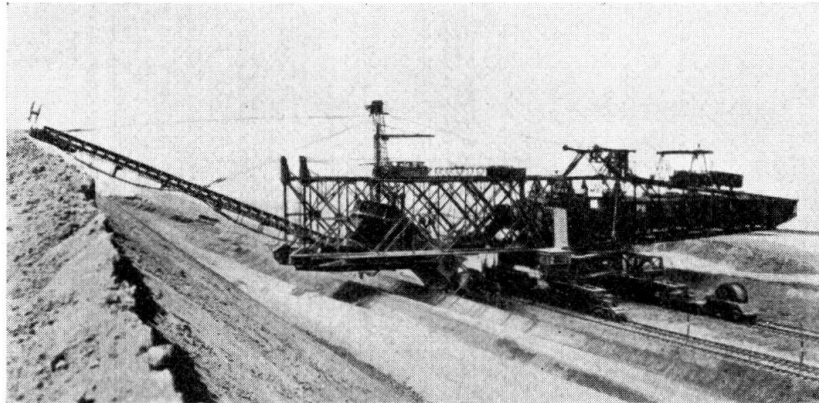

Fig. 2.

The steel structures in question serve to carry the plant for loosening and loading the coal (Fig. 1), dumping the spoil (Fig. 2) and refilling the emptied lignite pits by means of conveyor belts over the shortest routes (Fig. 3). These structures are subject to numerous external forces, some of which are scarcely known even as to their order of magnitude, and they move on rails laid

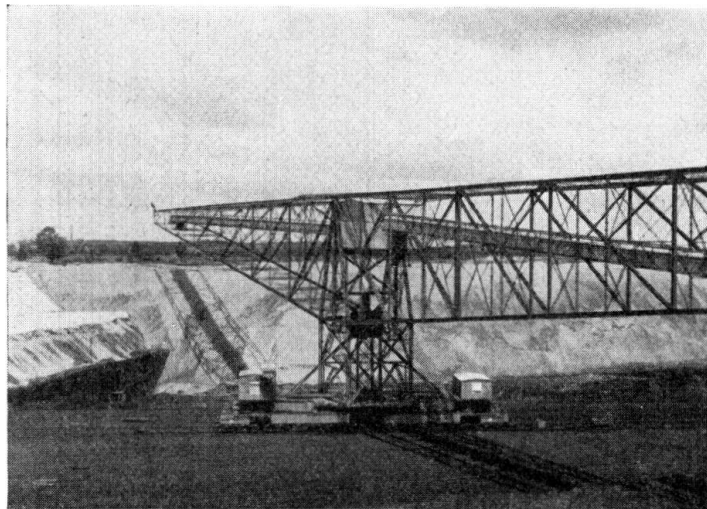

Fig. 3.

directly on the ground which are continuously being shifted about by machines, so that while the plant is operating its inclination to the horizontal is continually changing.

In this way a large elastically connected structure, subject to heavy loads, has to be supported over a large area at a large number of points which are moveable in all three dimensions so that only small supporting reactions are pro-

duced (Fig. 4). This is secured by the use of suitable balancing devices or hydraulically coupled cylinders, so arranged as to obtain a three-dimensional chain of elastic members with considerable freedom of displacement relatively to one another. The need for the supporting points to be free to move vertically

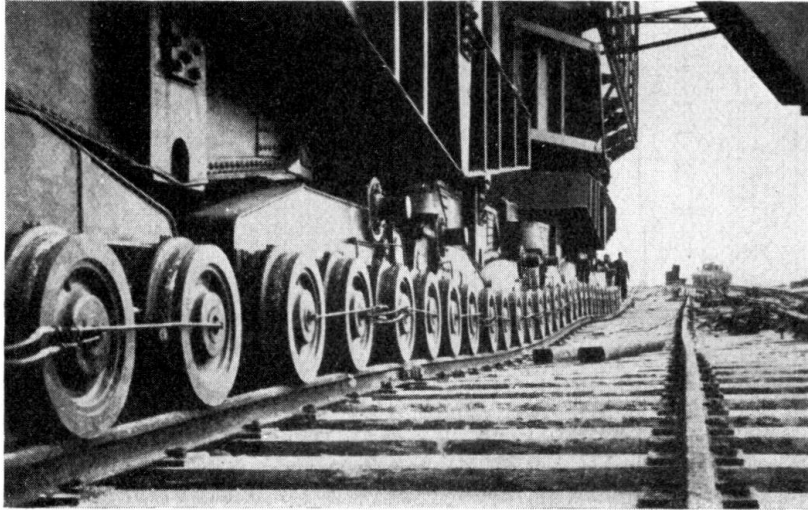

Fig. 4.

and horizontally (within certain limits) compels the adoption of a three-dimensional system which is kinematically determined and which, when the degree of freedom conferred upon it to allow for movement is removed, will remain kinematically rigid in all its positions, retaining no further power even of infinitesimal movement. In this way all reactions and intermediate forces between

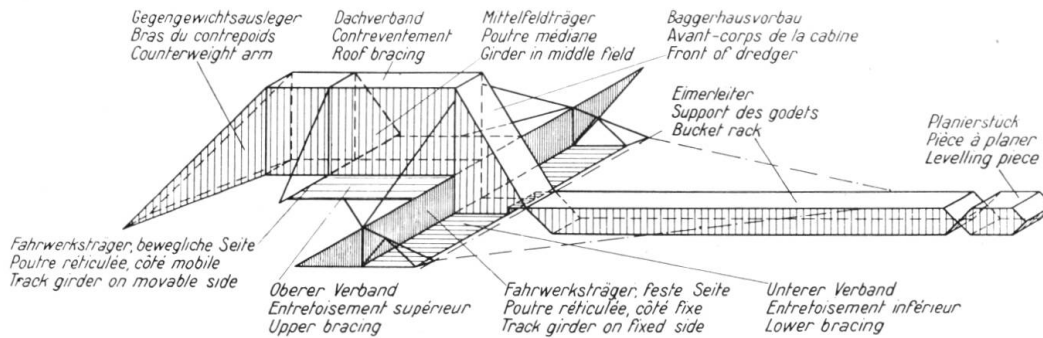

Fig. 5.

The winding gear and supporting mast of the bucket rack are omitted.

the members of the chain will be statically determinate for any system of loading in all three dimensions, regardless of how the machine as a whole is being moved about on caterpillar tracks or on wheels running on rails which may be curved in space relatively to one another. It follows, therefore, that the statically determinate system has to be such as will satisfy analysis carried down to each individual wheel, whatever system of external loading is assumed.

The members composing the three-dimensional chain are made up of lattice work, or space structures, connected by two, three or four bar links with journal,

ball or roller bearings, or hinges. These members serve as supporting structures for mechanical and electrical plant; or for the balancing arms, motion gear and platforms of slewing apparatus. They have, therefore, to be either latticed or plated girders in three dimensional arrangement, rigid against bending or torsional effects in any direction.

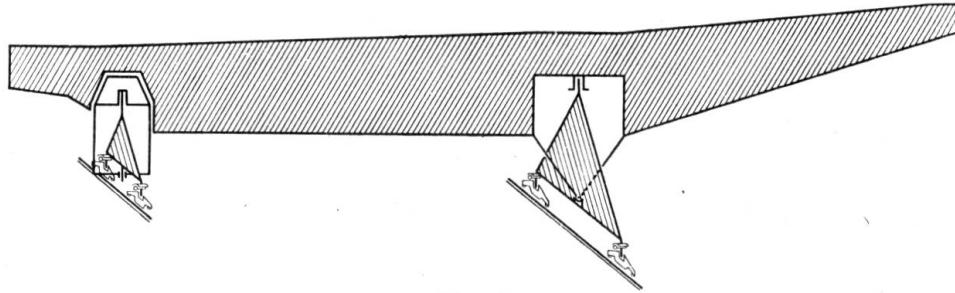

Fig. 6.

Examples may be seen in the outline sketch of the space frame work for a deep dredger with three-point support (Fig. 5), and in that of the structure moveable in three dimensions which serves to carry a spoil conveyor (Fig. 6).

Here, under patents of the Mittel-deutschen Stahlwerke, the axis of the girder can be swung to 45° from the direction of travel.

In all work of this kind the designer is compelled to concern himself with many three-dimensional problems foreign to the usual practice of structural engineering, and has continually to refer back to the fundamentals of mechanics and elastic theory in order to develop methods suitable for his needs, or to assess the validity of approximate solutions by making rigorous investigations of the statics of plates, shells or slabs.

Frequently these problems consist in the calculation of statically determinate or indeterminate lattice space structures under three-dimensional systems of loading (Fig. 7), and in the examination

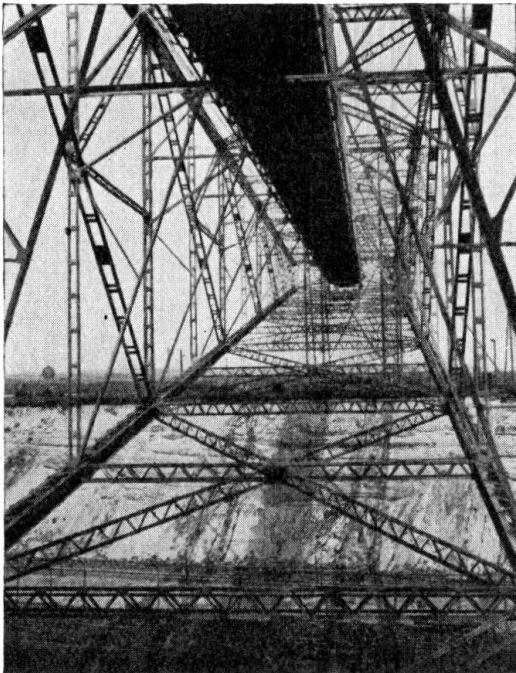

Fig. 7.

of surface structures for supporting a truck with a slewing motion and distributing the wheel loads (which are imposed on a relatively small portion of the platform) over as large an extent of the track as possible. For this purpose use is made of supporting structures which are rigid against bending and twisting, and which are carried on three points hydraulically compensated under heavy loads. Four pairs of plate web girders intersecting one another are gusseted on the upper and lower flanges in order to provide the necessary degree of rigidity against torsion.

The structure can also be developed from a circular girder with one or two concentric cylinders, having its flanges stiffened by horizontal discs. The reactions are then taken up either directly, or through two arms projecting from the ring (Fig. 8). The circular rail is carried on the outer girder and the remaining portion of the structure serves as a rule only to resist shear forces. The arrangement may also be adapted as in Fig. 9 (which shows a plan and cross section) whereby the transfer of forces is simplified and economy is realised. The conditions of stress and displacement of these elastic structures cannot be ascertained by the usual simple rules of design, but call for more general methods derived from elastic theory if a useful picture of the action is to be obtained and a useful basis for design is to be derived.

It will be seen, then, that the design of heavy plant for lignite mining compels a clearer elucidation of the action of space structures than is usually deemed necessary in bridge or building work. The solution of these structural

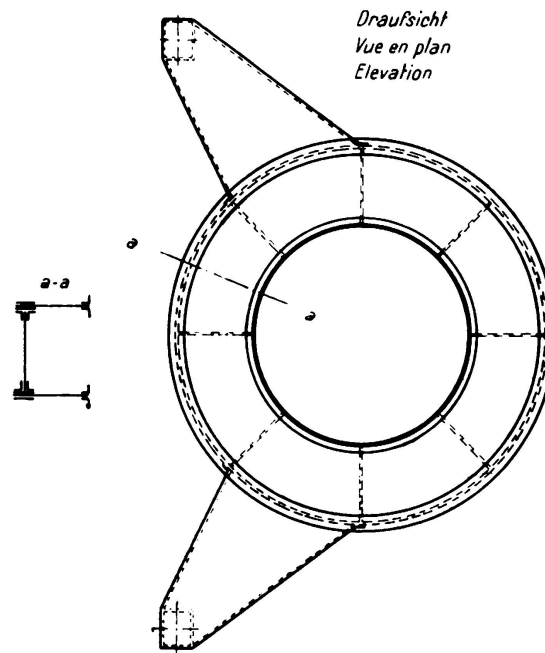

Fig. 8.

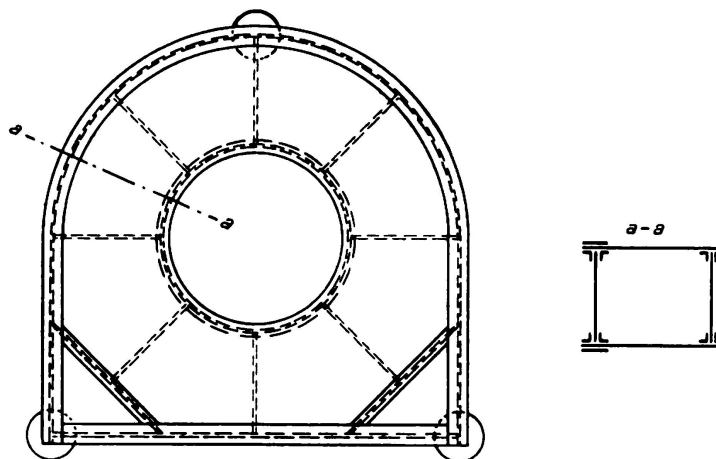

Fig. 9.

and mechanical problems is a service carried out by the Maschinenfabrik Magdeburg-Buckau, the Lübecker Maschinenbau-Gesellschaft, the Mitteldeutschen Stahlwerke, and the excavator department of Friedrich Krupp A.-G., Essen.