

Experiments on rolled sections strengthened by welding

Autor(en): **Bryla, St. / Chmielowiec, A.**

Objekttyp: **Article**

Zeitschrift: **IABSE congress report = Rapport du congrès AIPC = IVBH
Kongressbericht**

Band (Jahr): **2 (1936)**

PDF erstellt am: **21.07.2024**

Persistenter Link: <https://doi.org/10.5169/seals-3318>

Nutzungsbedingungen

Die ETH-Bibliothek ist Anbieterin der digitalisierten Zeitschriften. Sie besitzt keine Urheberrechte an den Inhalten der Zeitschriften. Die Rechte liegen in der Regel bei den Herausgebern.

Die auf der Plattform e-periodica veröffentlichten Dokumente stehen für nicht-kommerzielle Zwecke in Lehre und Forschung sowie für die private Nutzung frei zur Verfügung. Einzelne Dateien oder Ausdrucke aus diesem Angebot können zusammen mit diesen Nutzungsbedingungen und den korrekten Herkunftsbezeichnungen weitergegeben werden.

Das Veröffentlichen von Bildern in Print- und Online-Publikationen ist nur mit vorheriger Genehmigung der Rechteinhaber erlaubt. Die systematische Speicherung von Teilen des elektronischen Angebots auf anderen Servern bedarf ebenfalls des schriftlichen Einverständnisses der Rechteinhaber.

Haftungsausschluss

Alle Angaben erfolgen ohne Gewähr für Vollständigkeit oder Richtigkeit. Es wird keine Haftung übernommen für Schäden durch die Verwendung von Informationen aus diesem Online-Angebot oder durch das Fehlen von Informationen. Dies gilt auch für Inhalte Dritter, die über dieses Angebot zugänglich sind.

V 3

Experiments on Rolled Sections Strengthened by Welding.

Versuche mit durch Schweißung verstärkten Walzträgern.

Essais sur poutres laminées renforcées par soudage.

Dr. Ing. St. Bryła,

Professeur à l'Ecole Polytechnique de Varsovie, et

Dr. Ing. A. Chmielowiec,

Professeur-adjoint à l'Ecole Polytechnique, Lwów.

The beams tested were 30 cm deep and covered a span of 2.00 m. They were subjected to concentrated loads applied at the centre of each beam, and the following types were examined (Figs. 1 and 2):

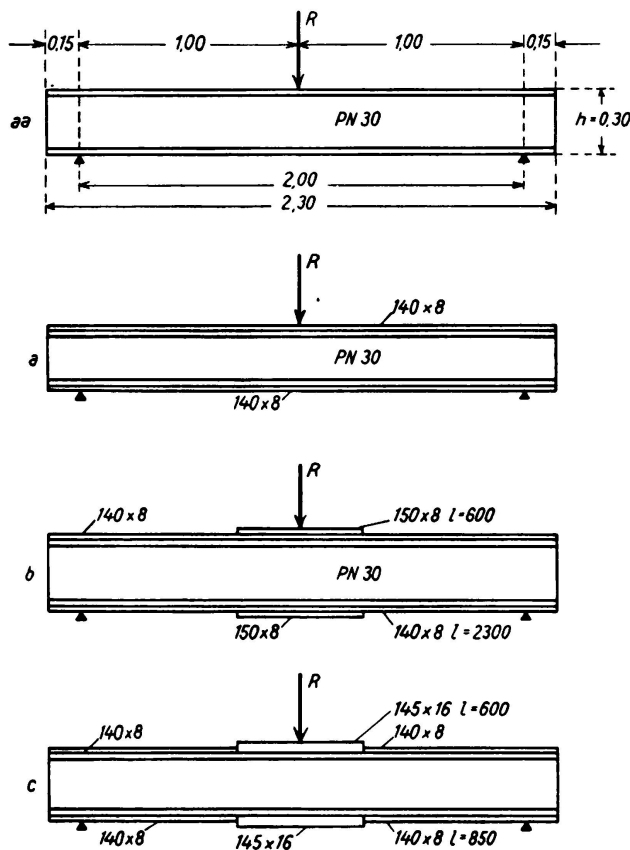

Fig. 1.

Type aa: Normal 30 cm joist.

Type a: Normal 30 cm joist reinforced with a $140 \cdot 8$ mm plate.

Type b: As type a, but reinforced with a $150 \cdot 8$ mm plate over a length of 60 cm at the middle of the span.

Type c: Same as type b, with the sole difference that instead of using two plates each 8 mm thick, a single plate measuring 145 · 16 mm was used at the centre (Fig. 3).

Each of these types was examined both without stiffeners (group I) and with stiffeners (group II) (Fig. 4). The latter group included two types of full webbed joists of compound section with $h = 30$ cm (Figs. 5 and 6).

Type d: with rivetted flange plates.

Type e: with welded flange plates.

Table I gives the weights of the beams examined (column 5) and the breaking loads R carried by them (column 4). In some cases a number of tests were carried

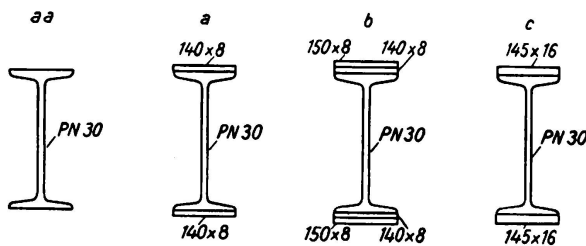

Fig. 2.

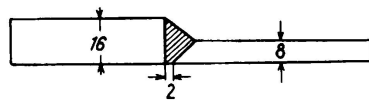

Fig. 3.

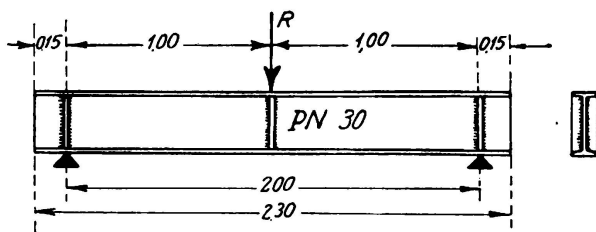

Fig. 4.

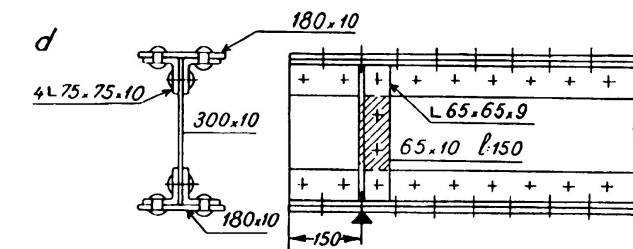

Fig. 5.

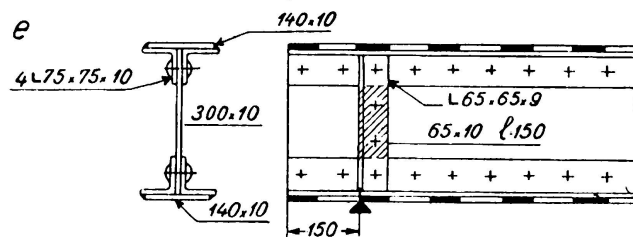

Fig. 6.

out on beams of identical type in the same group, and R then denotes the arithmetic mean of the results so obtained. Column 6 in Table I gives the breaking load per unit weight (or specific breaking load) $r = R/G$ and Table I has been used as a basis for calculating Tables II, III and IV which show the increase in absolute and in specific breaking load for one type of beam in relation to another. The addition of a flange plate increases the absolute load much more than the specific breaking load, and this increase is more marked in group II than in group I. On the other hand, the addition of a short flange plate (type b) is more advantageous in the case of group I. Type b is the most economical, giving values of R and of r approximately 10% higher, whatever the group under consideration. The welding of a plate to a

joist is particularly advantageous when it is required to increase the strength of such a beam without greatly increasing its depth.

Table I.

1	2	3	4	5	6
Group	Type	Number of tests	R in t	G kg	r = R : G
I Beams without stiffeners	aa	1	39.9	124.75	320
	a	3	54.7	165.25	330
	b	1	62.5	176.55	354
	c	1	68.5	176.55	388
II Beams with stiffeners	aa	3	48.4	133.58	362
	a	9	71.3	174.08	409
	b	2	76.75	185.38	414
	c	1	84.5	185.38	455
	d	2	79.0	256.6	308
e	2	74.9	242.2	309	

Table II.

Group	I	II
R _a —R _{aa}	37.2 %	47.4 %
R _b —R _a	14.25 „	7.65 „
R _c —R _a	25.3 „	18.5 „
R _c —R _b	9.6 „	10.0 „

Table III.

Group	I	II
r _a —r _{aa}	3.12%	13.0%
r _b —r _a	7.3 „	1.5 „
r _c —r _a	17.5 „	11.2 „
r _c —r _b	9.6 „	9.9 „
r _b —r _{aa}	10.6 „	14.4 „
r _c —r _{aa}	21.2 „	26 „

Table IV.

Group	I	II
r _{aa} —r _e	2.8%	17 %
r _a —r _e	5.4 „	32.4 „
r _b —r _e	11.5 „	34 „
r _c —r _e	20.2 „	47 „

The two types d and e give almost the same value from the economic standpoint; $r = 308$ and 309 , this being a little lower than is obtained with the rolled joists. It appears from Table IV that beams without stiffeners are from 2.8 to 20% more economical than compound beams with stiffeners. Rolled joists with stiffeners show an economic advantage of between 17 and 47%, but it is necessary to take account also of the amount of labour involved, which is much greater in compound beams than in others. In rivetted work compound beams are often preferred to rolled joists (for instance in the longitudinal and cross girders of bridges) since it is difficult to connect rolled joists to one another by riveting (as where the longitudinals have to be connected to the cross girders), but with welded work this difficulty disappears and there is every reason for preferring rolled joists to compound sections, whether reinforced or not; their construction is simpler, their weight lower and their strength greater. Herein lies one of the greatest advantages of welded over riveted work.

At the instant of failure of the beam the stress

$$\sigma = \frac{M}{J} \cdot v = \frac{M}{W}$$

should be equal to the breaking stress of the steel, assuming that failure is due to bending and that the steel exactly obeys *Hooke's* law. But by reason of the horizontal break in the stress-strain curve the bending moment M , and with it the breaking stress, are increased by approximately 16% in the case of double T sections, giving

$$M = \frac{R \cdot L}{4} = 1.15 W \cdot \sigma \quad \text{or} \quad \sigma = \frac{R \cdot L}{4 \cdot 1.15 W} = \frac{R}{B}$$

for $L = 200 \text{ cm}, \quad B = \frac{1.15 W}{50 \text{ cm}}.$

Table V gives the stresses σ as calculated by these formulae. If the material were perfectly homogeneous and if all the beams were monolithic and all failed by bending the σ values in Table V would all be equal to the yield point of the metal. In monolithic beams of type aa and in semi-monolithic beams of type a, the material is better utilised than in beams built up of a number of elements, such as types d, e, b and c. This is the reason why the latter show less favourable results than the former. In type b the dangerous section is not necessarily at the centre of the beam; it occurs more probably at a distance of 250 mm from the centre, where the second flange plate is not yet effective. The values obtained for the beams without stiffeners are much lower than those obtained for the same

Table V.

Type	W cm ³	B cm ²	σ kg/mm ²	
			Group	
			I	II
aa	653	15.07	26.4	32
a	958	22.05	24.8	32.4
b	1292	29.80	21	25.8
c	1292	29.80	23	28.4
d	1246	28.68		27.6
e	1154	26.50		28.2

beams with stiffeners (group II), and it may be concluded that the beams without stiffeners failed not by bending but by the collapse of the web. The concentrated load applied on the upper flange of the beam gives rise to transverse stresses, that is to say to a vertical compression under the load, and these stresses are at a maximum in the upper portion of the beam immediately below the

flange; when they exceed the yield point the web buckles. For the purpose of calculating these transverse stresses σ_z Professor *M. T. Huber*¹ assumes that the compression flange behaves like a beam supported on an elastic base; where I_s is the moment of inertia of this beam, h_1 its height and δ the thickness of the web of the joist, we obtain

$$\sigma_z = \frac{R \alpha}{2 \delta}, \quad \alpha^4 = \frac{0.4 \delta}{I_s \cdot h_1}.$$

To take account of the rigid connection between the web and the flange, the transverse stress must be reduced by 8% (by analogy with a uni-

¹ Prof. *M. T. Huber*: Étude des poutres en double té. Comptes-rendus des séances de la Société technique. Warsaw, 1923.

formly distributed load). In a joist PN 30, $\delta = 1.08$ cm, $h_1 = 26$ cm, and we have

$$\sigma_z = \frac{R}{\Lambda}, \quad \Lambda = 6.55 \sqrt[4]{I_s}$$

Table VI gives the values of σ_z calculated according to these formulae, which are much greater than the stresses caused by bending in the case of the beams without stiffeners (Table V, group I); this goes to prove that it is the transverse stresses which cause failure in the beams not provided with stiffeners.

Table VI.

Beams without stiffeners.

Type	J_s cm ⁴	Λ cm ²	σ_z kg/mm ²
aa	5.05	9.85	40.50
a	16.57	13.26	41.28
b	39	16.40	38.10
c	39	16.40	41.80

Table VII.

Beams with stiffeners.

Type	1.59 Λ cm ²	σ_z kg/mm ²
aa	15.70	32.5
a	21.14	33.8
b	26.0	29.55
c	26.0	32.75

It may surprise that the values of σ_z exceed the yield point, but this circumstance may be explained by the fact that the tests were not stopped at the precise instant when the stress σ_z reached the yield point; the load still continued to be increased, and as the result of the strains which occurred it was distributed over a strip of some considerable width, thereby reducing the stresses at the central point.

Assuming that the stiffeners placed immediately underneath the load R serve to distribute that load equally between the two flanges, we obtain transverse stresses amounting to only $\frac{1}{1.59}$ times as great,² hence

$$\sigma_z = \frac{R}{1.59 \Lambda}$$

Table VII shows the stresses as calculated by this formula in the beams without stiffeners; here again the values are higher than those in Table V, group II, but the differences are not so great as to exclude the possibility that the beams may have failed by bending. This may be seen in the illustrations. The lower flange of the beam without stiffeners (Fig. 7) is intact (the vertical stresses are here equal to zero), while the upper flange has bent as well as the web. In the beams with stiffeners (Figs. 8, 9 and 10) the two flanges have been visibly bent immediately under the point of application of the concentrated load, and this proves that the stresses due to bending have contributed to the failure of the beam. In the case shown in Figs. 8 and 9, the plate of the upper flange has become wavy, and in the case of Fig. 8 the weld seams have been torn away; this represents the effect of the transverse stresses, but it is also an effect of the

² *Bryla*: Influence des raidisseurs d'âme soudés aux poutrelles, sur leur résistance. Annales de l'Académie des Sciences techniques, Warsaw, 1935, I, p. 152.

buckling of the compression flange, which is free so to buckle intermediately between the weld seams. This explains why the flange plates have not bent in the beam with continuous weld seams (Fig. 10).



Fig. 7.

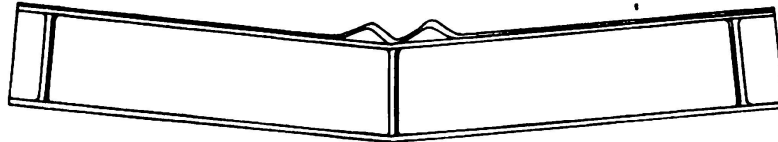

Fig. 8.

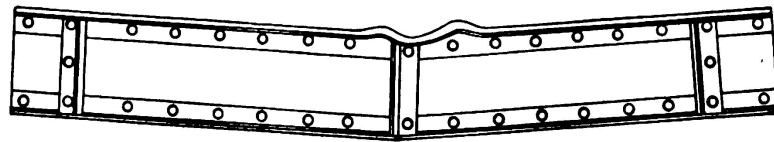

Fig. 9.



Fig. 10.

Conclusion.

The addition of a flange plate to a beam increases the value of the breaking load R (Table I). The specific breaking load (per kg weight of beam) $r = R/G$ increases in a smaller proportion. Beams of compound section are inferior to rolled joists, whether or not these are reinforced by flange plates. A single thick flange plate is to be preferred to two plates of smaller thickness. In beams without stiffeners, failure through collapse of the web is due to the vertical compression below the point of application of the concentrated load, and not to stresses caused by bending (see Tables V and VI and Fig. 7). In the case of beams provided with stiffeners the stresses due to bending have contributed to the failure (see Tables V and VII and Figs. 8, 9 and 10).