

Some special cases of buckling

Autor(en): **Eb, W.J. van der**

Objektyp: **Article**

Zeitschrift: **IABSE congress report = Rapport du congrès AIPC = IVBH
Kongressbericht**

Band (Jahr): **4 (1952)**

PDF erstellt am: **22.07.2024**

Persistenter Link: <https://doi.org/10.5169/seals-5030>

Nutzungsbedingungen

Die ETH-Bibliothek ist Anbieterin der digitalisierten Zeitschriften. Sie besitzt keine Urheberrechte an den Inhalten der Zeitschriften. Die Rechte liegen in der Regel bei den Herausgebern.

Die auf der Plattform e-periodica veröffentlichten Dokumente stehen für nicht-kommerzielle Zwecke in Lehre und Forschung sowie für die private Nutzung frei zur Verfügung. Einzelne Dateien oder Ausdrucke aus diesem Angebot können zusammen mit diesen Nutzungsbedingungen und den korrekten Herkunftsbezeichnungen weitergegeben werden.

Das Veröffentlichen von Bildern in Print- und Online-Publikationen ist nur mit vorheriger Genehmigung der Rechteinhaber erlaubt. Die systematische Speicherung von Teilen des elektronischen Angebots auf anderen Servern bedarf ebenfalls des schriftlichen Einverständnisses der Rechteinhaber.

Haftungsausschluss

Alle Angaben erfolgen ohne Gewähr für Vollständigkeit oder Richtigkeit. Es wird keine Haftung übernommen für Schäden durch die Verwendung von Informationen aus diesem Online-Angebot oder durch das Fehlen von Informationen. Dies gilt auch für Inhalte Dritter, die über dieses Angebot zugänglich sind.

AII 2

Some special cases of buckling

Une étude du flambage en certains cas particuliers

Einige besondere Knickfälle

IR. W. J. VAN DER EB

Research Engineer, T.N.O., Delft, Holland

BUCKLING OF LATTICED STRUTS WITH LONG BATTENS ONLY

When the lengths of the battens are not neglected, the system of the latticed strut may be supposed to consist of coupled parts having a moment of inertia I_t and a length $2e$, and parts to be coupled whose two components are self-supporting "single sections," each having a moment of inertia I_e and a length c . The distance between the centres of the battens is termed l , so that equation $l=c+2e$ is valid. Furthermore, the angular displacement of the centre of the p th batten is indicated as ψ_p , whilst the difference between the angular displacements of the ends of this p th batten is referred to as $\Delta\phi_p$ (figs. 1 and 2).

In considering any given $(p+1)$ th element (of a single section) of the parts to be coupled, it is found that the following differential equation must be applied:

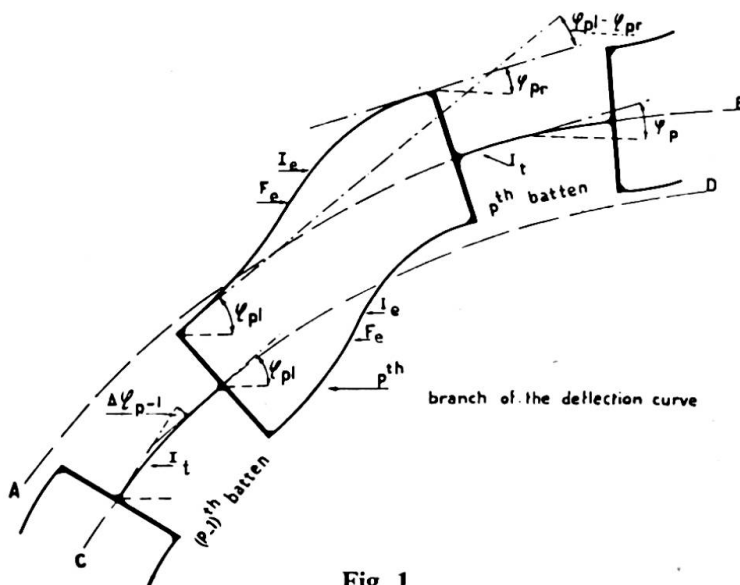

Fig. 1

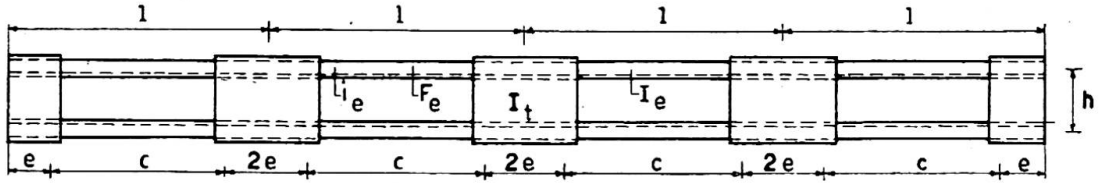

Fig. 2

$$\frac{d^2y}{dx^2} = -\frac{P}{E\tau I_e}y + \frac{M_p}{E\tau I_e}$$

whilst for the coupled parts

$$\frac{d^2y}{dx^2} = -\frac{2P}{E\tau I_t}y$$

is valid. With the boundary conditions that must hold for the parts to be coupled:

$$\begin{aligned} \text{where} \quad x=pl+e: & \quad y' = \phi_{(p+1)l} \\ x=(p+1)l-e: & \quad y' = \phi_{(p+1)r} \end{aligned}$$

and for the coupling parts:

$$\begin{aligned} \text{where} \quad x=pl-e: & \quad y' = \phi_{pr} \\ x=pl+e: & \quad y' = \phi_{(p+1)l} \end{aligned}$$

(l and r denoting "left" and "right").

In this way, after introducing the conditions of equilibrium and continuity, the equation of finite differences by which the problem is defined is found to be:

$$\begin{aligned} \left[\frac{Pc \cos a_1 e}{a_2 c \sin a_2 c} + \frac{\cos a_1 e}{\eta} \right] \Delta^2 \psi_p + \left[\frac{Pc \cdot 2(1 - \cos a_2 c) \cos a_1 e}{a_2 c \sin a_2 c} \right. \\ \left. + \frac{2Pe \cdot 2(1 - \cos 2a_1 e) \cos a_1 e}{2a_1 e \sin 2a_1 e} \right] \psi_p + \left[\frac{Pc}{a_2 c \sin a_2 c} + \frac{1}{\eta} \right] \frac{\Delta \phi_{p+1} - \Delta \phi_{p-1}}{2} = 0 \end{aligned}$$

in which $a_1 = 2P/E\tau I_t$, $a_2 = \sqrt{P/E\tau I_e}$, $2P = \text{total buckling force}$, $\eta = 4C/E\tau F_e h^2$, $F_e = \text{cross-sectional area of the single section}$ and $h = \text{distance between the centres of gravity of the single sections}$. As large battens, having great rigidity with respect to "Vierendeel" deformation, are being dealt with, their deforming effects may be assumed to be infinitely small and are therefore neglected.

An exact solution of this equation of finite differences which also satisfies the boundary conditions, not to be mentioned here, is obtained at such a state of buckling deformation that the deflection curves of the centre lines of the battens are all situated on sinusoidal curves of the same form, displaced in a parallel sense with respect to each other, of which only that with one wave between the bar-ends will, of course, represent the least favourable condition. Introducing the solution indicated, the general buckling condition is found to be:

$$Z = \frac{\frac{2\alpha\pi}{m} \left[\cos \frac{\beta\pi}{m} \left(\cos \frac{\pi}{n} - \cos \frac{\alpha\pi}{m} \right) - \sin \frac{\pi}{n} \sin \frac{(1-\alpha)\pi}{2n} \right] + \frac{\alpha(1-\alpha)}{2} \frac{\beta\pi}{m} \cdot \sin \frac{\beta\pi}{m} \cdot \sin \frac{\alpha\pi}{m}}{\sin \frac{\alpha\pi}{m} \left[\cos \frac{\beta\pi}{m} \left(1 - \cos \frac{\pi}{n} \right) + \sin \frac{\pi}{n} \sin \frac{(1-\alpha)\pi}{2n} \right]}$$

in which $\alpha = c/l$ and $\beta = \frac{1}{2}(1-\alpha)\sqrt{2I_e/I_t}$ and $n = \text{number of panels}$, whilst m is the coefficient of the virtual buckling length defined by the equation:

$$P = \frac{\pi^2 E\tau I_e}{m^2 l^2}$$

and

$$Z = \frac{h^2}{2i_e^2}$$

This formula takes into account all extreme cases, for if $c=0$, that is, $2e=l$, then α becomes 0, whilst $\beta^2 = \frac{1}{2}I_e/I_t$. Moreover, $\cos \alpha\pi/m$ approximates to unity and $\sin \alpha\pi/m$ approximates to $\alpha\pi/m$.

The buckling condition is reduced to:

$$\begin{aligned} \frac{1}{2}Z &= \frac{\cos \frac{\beta\pi}{m} \left(\cos \frac{\pi}{n} - 1 \right) - \sin \frac{\pi}{n} \sin \frac{\pi}{2n}}{\cos \frac{\beta\pi}{m} \left(1 - \cos \frac{\pi}{n} \right) + \sin \frac{\pi}{n} \sin \frac{\pi}{2n}} \\ &= \frac{\cos \frac{\beta\pi}{m} \left(\cos \frac{\pi}{n} - 1 \right) - \cos \frac{\pi}{2n} \left(1 - \cos \frac{\pi}{n} \right)}{\cos \frac{\beta\pi}{m} \left(1 - \cos \frac{\pi}{n} \right) + \cos \frac{\pi}{2n} \left(1 - \cos \frac{\pi}{n} \right)} \end{aligned}$$

or

$$\begin{aligned} \left[\frac{1}{2}Z + 1 \right] \cdot \cos \frac{\beta\pi}{m} &= - \left[\frac{1}{2}Z + 1 \right] \cdot \cos \frac{\pi}{2n} \\ \cos \frac{\beta\pi}{m} &= - \cos \frac{\pi}{2n} = \cos \frac{\pi}{2n} \end{aligned}$$

or

$$\frac{\beta\pi}{m} = \frac{2n}{\pi}$$

therefore

$$m = 2\beta n$$

Thus the total buckling force becomes, under condition $\beta^2 = \frac{1}{2}I_e/I_t$:

$$2P = \frac{2\pi^2 E \tau I_e}{4\beta^2 n^2 l^2} = \frac{\pi^2 \cdot E \cdot \tau \cdot I_t}{n^2 l^2}$$

which is correct.

When $c=l$, that is, $e=0$, then $\alpha=1$, $\beta=0$, and the following is obtained:

$$Z = \frac{2 \frac{\pi}{m} \left[\cos \frac{\pi}{n} - \cos \frac{\pi}{m} \right]}{\sin \frac{\pi}{m} \left(1 - \cos \frac{\pi}{n} \right)}$$

being the simple formula already found by several authors.

When the battens are very narrow, their "Vierendeel" deformation is no longer negligible and it is necessary to equate for Z as follows:

$$Z = \frac{\frac{h^2}{2i_e^2}}{1 + \frac{E \tau F_e h^3 \left(1 - \cos \frac{\pi}{n} \right)}{24cEI_k}}$$

where I_k is the moment of inertia of the battens with respect to their "Vierendeel" effect. If the battens are infinitely weak, $I_k=0$, and in that case $Z=0$. It is then found from the buckling condition that $m=n$, and the total buckling force is then:

$$2P = \frac{2\pi^2 E \tau I_e}{n^2 l^2}$$

which is also correct.

Therefore, as has already been shown, all the extreme cases have been taken into account in the formula.

When transposing the above-mentioned buckling condition, a fortunate fact appeared, viz. that in practical cases the effect of β is very slight. Thus, for example, values were found as in the following table:

$n=3 \quad \alpha=0.6$			$n=6 \quad \alpha=0.6$		
m	$\beta=0.02$ $Z=$	$\beta=0.12$ $Z=$	m	$\beta=0.02$ $Z=$	$\beta=0.12$ $Z=$
0.7	29.39	28.41	0.9	49.80	49.36
1.1	5.23	5.21	1.4	15.26	15.22
1.9	0.176	0.172	2.7	2.30	2.29

The values of β applied in the above table were based on boundary values for $\sqrt{2I_e/I_t}$ equal to about 0.1 and 0.6. This quantity varies in practice between approximately these amounts. It may be seen from the values shown above that if tables are compiled for the average value, i.e. for $\sqrt{2I_e/I_t}=0.35$, the error incurred in Z will at most be 1%, and furthermore this error rapidly diminishes if m increases (i.e. with Z decreasing).

This affords considerable simplification in the numerical tables and in the application of the theory. In computing Tables I to IV, a value of β based on $\sqrt{2I_e/I_t}=0.35$ has been introduced. Furthermore, five values of α have been introduced, viz. 0.6, 0.7, 0.8, 0.9 and 1. The various lines (figs. 4 to 7) have been plotted in ten points, intermediate values being established from curves drawn as accurately as possible.

Method of calculation

Calculate: $Z=h^2/2i_e^2$ and $\alpha=c/l$ in which $c=l-2e$.

The corresponding value of m can immediately be found from Tables I to IV. Then the virtual ratio of slenderness of the strut is:

$$\lambda_{virt} = \frac{ml}{i_e}$$

in which:

i_e = radius of gyration of the single cross-section;

h = distance between centres of gravity of the component sections;

l = distance between centres of battens measured along centre-line of bar;

c = the length to be taken into account of the sections to be coupled;

$2e$ = length of battens minus twice the distance between two rivets in the case of riveted constructions. In the case of welded constructions the entire length of the batten is allowed to be taken into account.

The virtual ratio of slenderness being known, the required admissible compressive stress σ_d can immediately be found in Table VI according to V.O.S.B. requirements.*

* V.O.S.B. = Netherlands Standards for the Designing of Steel Bridges.

Hence the admissible compressive force = $2F_e \cdot \sigma_d$, in which $2F_e$ = total gross cross-sectional area.

Numerical example (fig. 3)

$h=14.6$ cm.; $i_e=2.02$ cm.; $i=6.95$ cm.; $c=90$ cm. and $l=120$ cm., whilst $n=4$ and $F_e=28.0$, so that:

$$Z = \frac{14.6^2}{2 \times 2.02^2} = 26.1$$

whilst $\alpha=90/120=0.75$, m is found to be about 1.05; hence

$$\lambda_{virt} = \frac{1.05 \times 120}{2.02} = 63$$

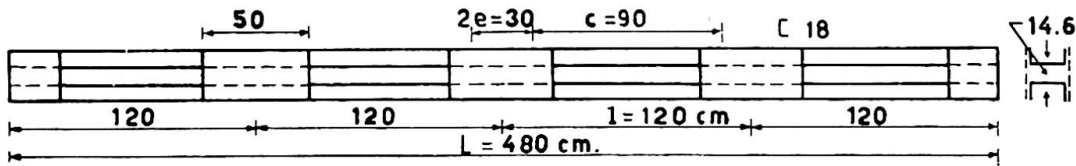

Fig. 3

TABLE I (fig. 4)

m	Z $\alpha=0.6$ $n=3$	Z $\alpha=0.7$ $n=3$	Z $\alpha=0.8$ $n=3$	Z $\alpha=0.9$ $n=3$	Z $\alpha=1$ $n=3$
0.60	~				
0.65	48.10				
0.70	29.00				
0.75	21.00	~			
0.80	15.40	65.00			
0.85	12.20	36.90			
0.90	10.10	23.40	~		
0.95	8.40	17.40	79.50		
1.00	7.05	13.70	41.00		
1.05	6.05	11.25	27.90	~	
1.10	5.20	9.40	20.30	97.30	
1.15	4.60	8.05	16.00	48.80	
1.20	4.05	6.95	13.00	32.00	~
1.25	3.40	6.05	10.85	23.85	119.70
1.30	2.90	5.20	9.35	18.70	59.20
1.35	2.55	4.50	8.00	15.20	38.90
1.40	2.20	4.05	6.90	12.70	28.60
1.50	1.70	3.50	6.05	10.85	22.30
1.60	1.20	3.05	5.30	9.40	17.80
1.70	0.80	2.65	4.10	8.10	15.20
1.80	0.50	2.05	3.30	6.30	12.90
1.90	0.17	1.55	2.50	5.00	9.65
2.00	0	1.10	1.95	3.95	7.50
2.10		0.75	1.50	3.10	5.95
2.20		0.40	1.20	2.50	4.80
2.30		0.20	0.95	2.05	3.85
2.40		0.10	0.70	1.75	3.15
2.50				1.55	2.55
2.60				1.30	2.05
2.70				1.10	1.65
2.80					1.30
2.90					1.00
3.00					0.75
					0.55
					0.35
					0.15
					0

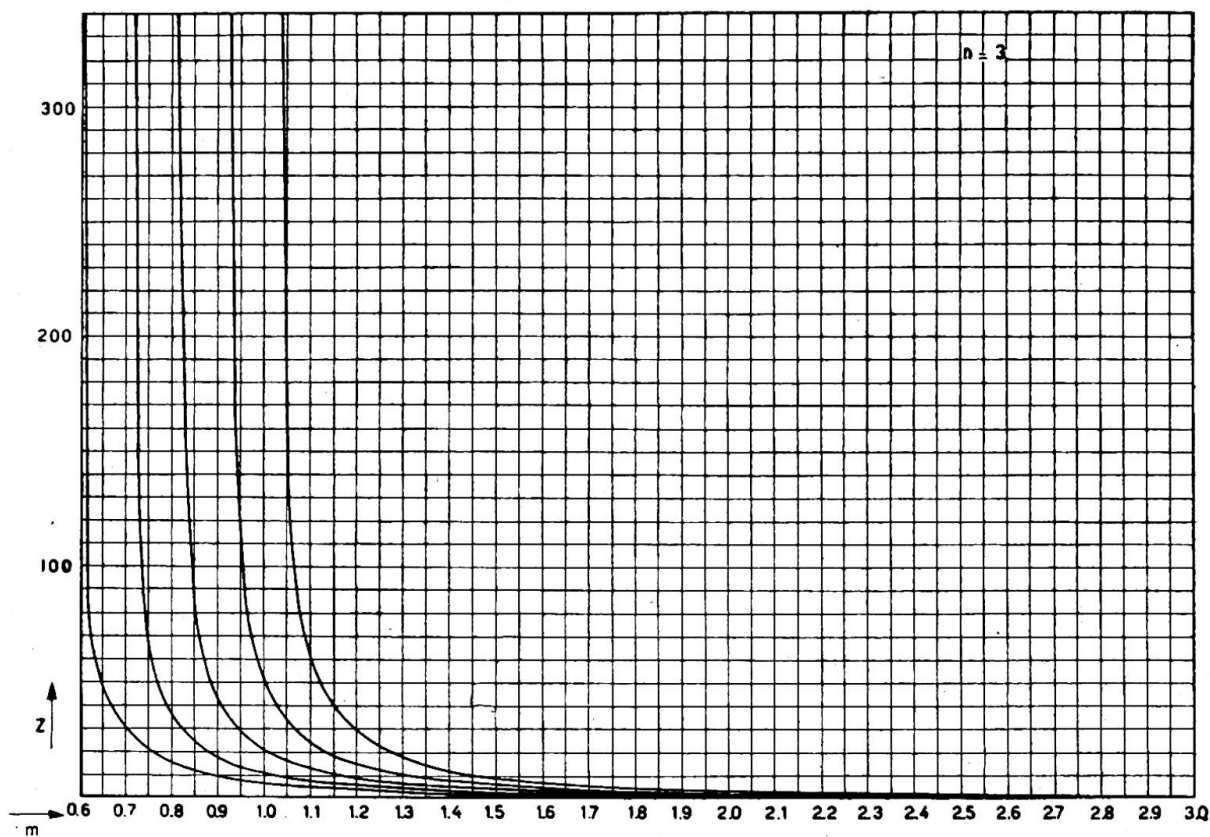

Fig. 4

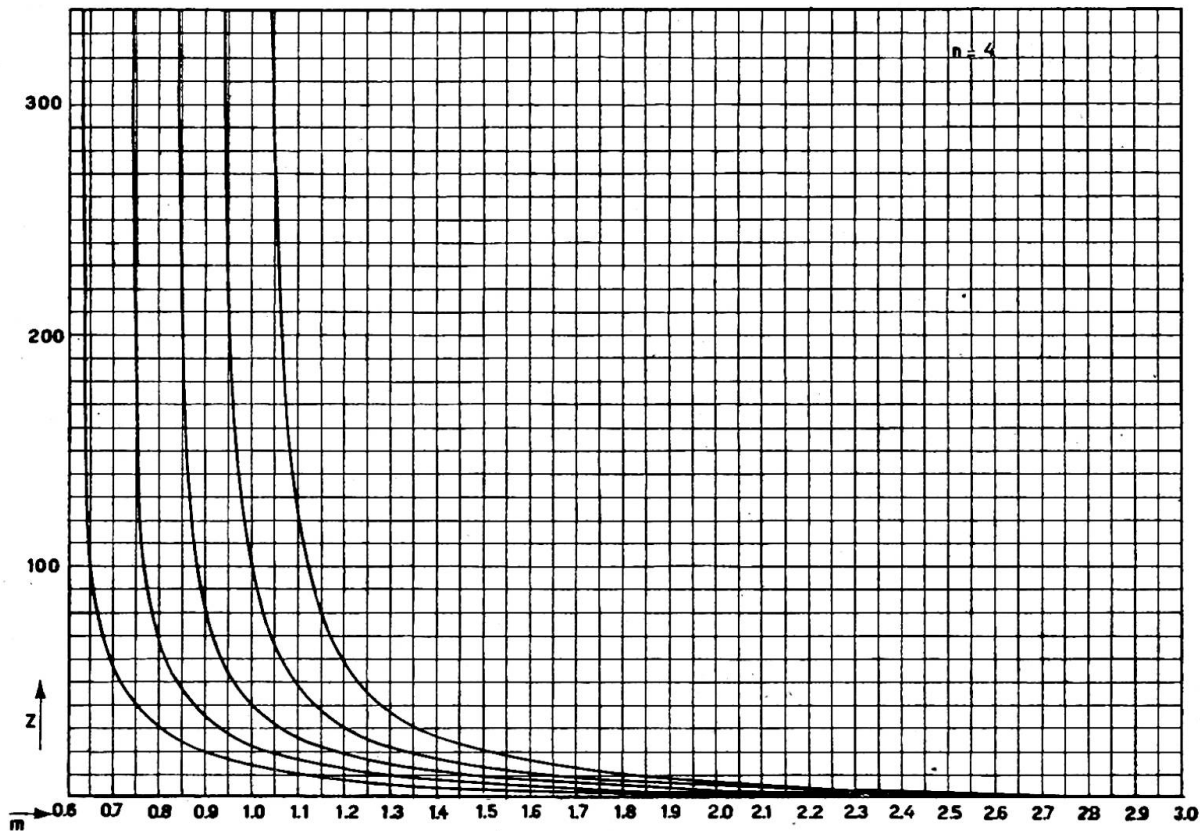

Fig. 5

The admissible compressive stress according to V.O.S.B. requirements is then 1,021 kg./cm.², so:

$$(P)=2 \times 28.0 \times 1,021 \text{ kg.} = 57.2 \text{ metric tons.}$$

The ratio of slenderness with respect to the x direction is:

$$\lambda_x = \frac{480}{6.95} = 69,$$

and the admissible compressive stress is then 952 kg./cm.², so

$$(P)=2 \times 28.0 \times 952 \text{ kg.} = 53.2 \text{ metric tons.}$$

The latticed strut therefore appears stronger with respect to the y axis than the x axis. If the length of the battens had been neglected, a virtual ratio of slenderness of $\lambda_{virt}=82$ and an admissible compressive stress of 800 kg./cm.² would have been found. In this case $P=44.7$ metric tons, whilst according to Engesser's formula $\lambda_{virt}=85$ and $P=42.7$ metric tons.

TABLE II (fig. 5)

<i>m</i>	Z α=0.6 n=4	Z α=0.7 n=4	Z α=0.8 n=4	Z α=0.9 n=4	Z α=1 n=4
0.60	~				
0.65	97.60				
0.70	57.50				
0.75	41.00	129.20			
0.80	30.55	67.25			
0.85	24.80	45.10	157.00		
0.90	20.30	34.75	79.70		
0.95	17.40	27.05	53.50	179.00	
1.00	14.70	22.95	40.25	95.50	
1.05	12.75	19.65	32.00	63.70	232.50
1.10	11.15	16.70	26.35	47.25	115.40
1.15	9.95	14.75	22.30	37.70	76.10
1.20	8.90	12.90	19.00	30.90	56.25
1.25	7.90	11.40	16.60	25.90	44.30
1.30	7.00	10.05	14.60	22.20	36.25
1.35	6.20	8.95	12.90	19.30	30.35
1.40	5.55	8.00	11.50	17.00	26.05
1.50	4.40	6.50	9.55	13.60	19.95
1.60	3.50	5.40	8.00	11.05	15.80
1.70	2.95	4.40	6.75	9.00	12.90
1.80	2.40	3.70	5.65	7.60	10.70
1.90	2.00	3.05	4.70	6.40	8.95
2.00	1.65	2.55	3.75	5.40	7.60
2.10	1.35	2.10	3.15	4.60	6.50
2.20	1.05	1.65	2.60	3.95	5.55
2.30	0.80	1.30	2.20	3.30	4.80
2.40	0.60	1.05	1.80	2.80	4.15
2.50	0.40	0.75	1.45	2.40	3.55
2.60	0.15	0.60	1.20	2.05	3.10
2.70	0	0.40	1.00	1.75	2.70
2.80		0.25	0.80	1.45	2.30
2.90		0.10	0.60	1.20	2.00
3.00		-0.05	0.50	1.00	1.70

BUCKLING OF BARS ELASTICALLY SUPPORTED AT INTERMEDIATE POINTS

The second case refers to the calculation of the stability of the upper chord of a low-truss bridge. There are already many publications on this subject. Thus, the

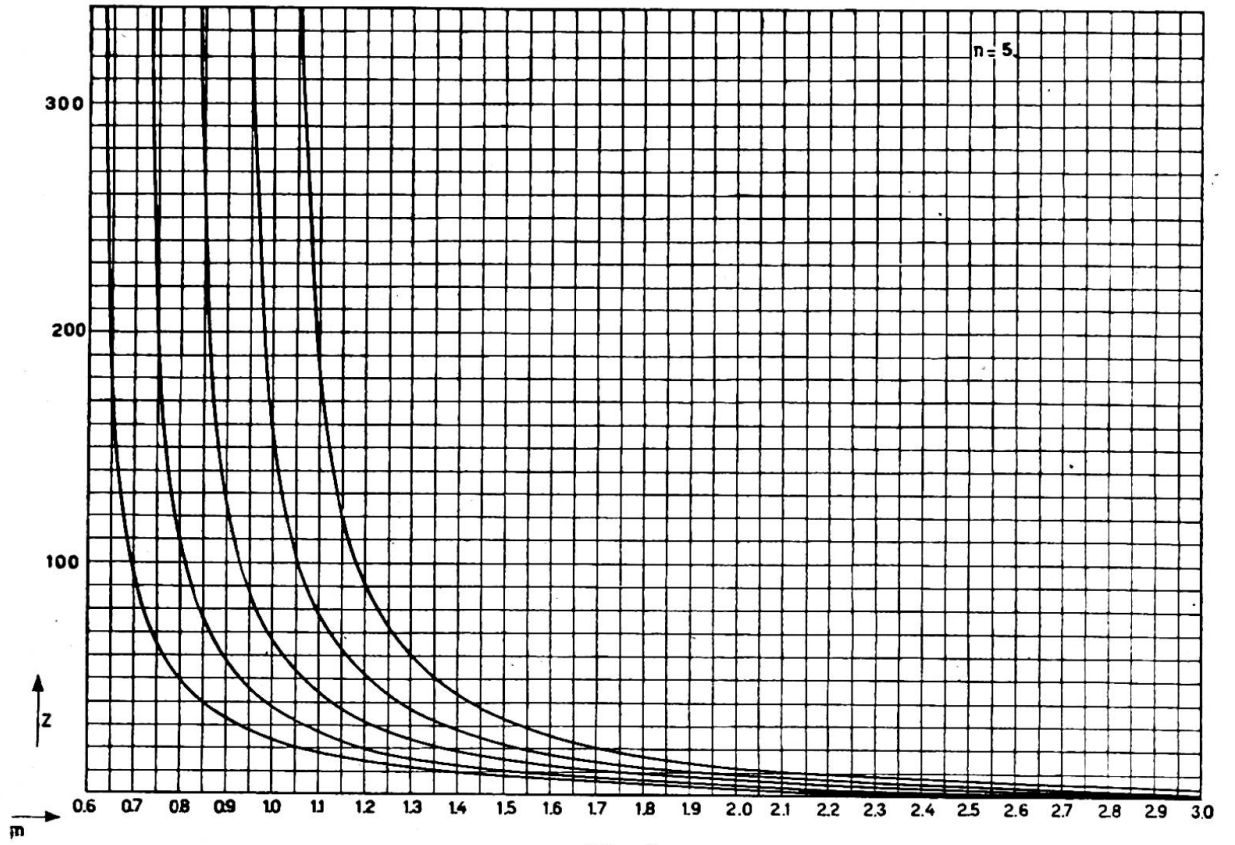

Fig 6

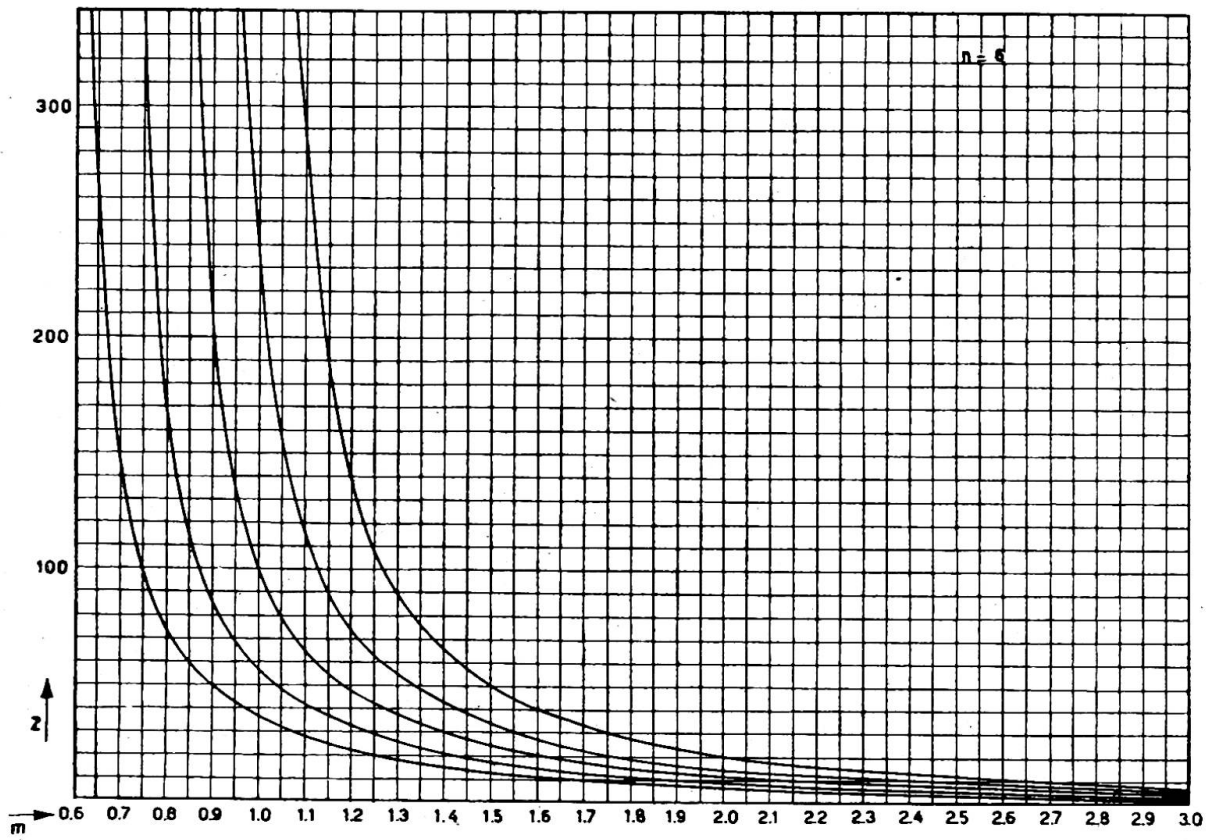

Fig. 7

TABLE III (fig. 6)

<i>m</i>	<i>Z</i> $\alpha=0.6$ <i>n</i> =5	<i>Z</i> $\alpha=0.7$ <i>n</i> =5	<i>Z</i> $\alpha=0.8$ <i>n</i> =5	<i>Z</i> $\alpha=0.9$ <i>n</i> =5	<i>Z</i> $\alpha=1$ <i>n</i> =5
0.60	~				
0.65	174.90				
0.70	95.50	~			
0.75	65.40	212.30			
0.80	50.50	110.60	~		
0.85	40.60	77.05	257.10		
0.90	33.50	57.00	130.50	~	
0.95	28.20	46.05	89.05	311.40	
1.00	24.60	37.90	66.00	156.50	~
1.05	21.50	32.00	52.80	105.50	378.00
1.10	18.90	27.70	43.50	77.40	178.80
1.15	16.85	24.20	37.00	62.00	123.95
1.20	15.05	21.50	31.90	50.90	91.85
1.25	13.40	19.00	27.80	42.75	72.45
1.30	12.10	17.00	24.60	36.90	59.40
1.35	10.90	15.30	21.80	32.00	50.10
1.40	9.90	13.90	19.60	28.40	43.05
1.50	8.30	11.60	16.40	22.70	33.15
1.60	6.90	9.70	13.60	18.50	26.50
1.70	5.80	8.10	11.25	15.50	21.75
1.80	4.90	7.00	9.55	13.15	18.25
1.90	4.20	5.95	8.20	11.30	15.50
2.00	3.50	5.10	7.10	9.70	13.30
2.10	3.05	4.50	6.20	8.50	11.55
2.20	2.60	3.80	5.40	7.40	10.10
2.30	2.10	3.30	4.70	6.50	8.85
2.40	1.80	2.80	4.10	5.70	7.80
2.50	1.55	2.35	3.60	5.05	6.90
2.60	1.30	2.00	3.15	4.50	6.15
2.70	1.05	1.75	2.70	3.90	5.50
2.80	0.90	1.50	2.40	3.50	4.90
2.90	0.70	1.25	2.10	3.10	4.40
3.00	0.60	1.05	1.80	2.75	3.90

case of a bar elastically supported at intermediate points with hinged ends has already been dealt with by Dr. Ing. Fr. Bleich in *Theorie und Berechnung der eisernen Brücken* (Theory and Dimensioning of Steel Bridges), whilst the same theme was subsequently treated by Prof. P. P. Bijlaard in *De Ingenieur*, No. 4, 1932, in an article entitled "Knikzekerheid van de bovenrand van open wandbruggen" (Buckling Resistance of the Upper Chord of a Low-Truss Bridge).

The same problem is dealt with below, but in this case with hinged elastically supported ends. Fig. 8 shows the condition for any given number of waves.

With $a^2=P/EI$, the differential equation of any given *p*th curve will appear in the general form:

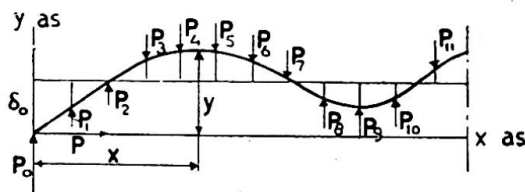

Fig. 8

$$\frac{d^2y}{dx^2} = -a^2y + \frac{S_p x + R_p c}{E\tau I}$$

in which S_p and R_p are values depending on the elastic reactions $p_1 \dots p_n$.

TABLE IV (fig. 7)

<i>m</i>	Z $\alpha=0.6$ $n=6$	Z $\alpha=0.7$ $n=6$	Z $\alpha=0.8$ $n=6$	Z $\alpha=0.9$ $n=6$	Z $\alpha=1$ $n=6$
0.60	~				
0.65	258.80				
0.70	144.00	~			
0.75	96.40	311.60			
0.80	73.00	163.30			
0.85	59.00	112.50	~		
0.90	49.70	84.50	379.50		
0.95	42.50	68.05	192.50		
1.00	36.50	56.50	131.50	458.90	
1.05	32.10	47.85	97.60	229.70	~
1.10	28.20	41.30	77.50	155.00	555.70
1.15	25.20	36.60	64.45	114.30	276.10
1.20	22.65	32.20	54.90	89.50	182.40
1.25	20.30	28.60	47.20	73.50	134.45
1.30	18.50	25.50	41.40	63.40	106.90
1.35	16.95	23.05	37.05	54.90	87.85
1.40	15.25	21.10	33.00	48.05	74.15
1.45	13.80	19.10	29.40	42.30	63.80
1.50	12.80	17.70	24.50	33.05	49.30
1.60	10.80	14.90	20.30	27.20	39.60
1.70	9.30	12.70	17.25	23.55	32.70
1.80	7.95	11.10	14.85	20.30	27.50
1.90	6.90	9.65	12.90	17.50	23.50
2.00	6.00	8.30	11.20	15.10	20.30
2.10	5.20	7.30	9.90	13.20	17.70
2.20	4.50	6.40	8.70	11.65	15.60
2.30	4.00	5.65	7.70	10.30	13.80
2.40	3.50	5.05	6.85	9.15	12.30
2.50	3.05	4.45	6.15	8.20	11.00
2.60	2.65	3.90	5.50	7.35	9.90
2.70	2.30	3.45	4.90	6.60	8.90
2.80	2.05	3.10	4.40	6.05	8.00
2.90	1.75	2.70	4.00	5.40	7.25
3.00	1.50	2.40	3.55	4.90	6.60

The boundary conditions for any given p th curve are as follows:

where $p=pc$: $y=y_{(p+1)l}$

where $x=(p+1)c$: $y=y_{(p+1)r}$

(l and r again denote "left" and "right").

Introducing the conditions of equilibrium and continuity, the following system of simultaneous equations of finite differences is obtained:

$$P_p = \frac{aP}{\sin ac} \Delta^2 \eta_p + \frac{2aP(1 - \cos ac) \eta_p}{\sin ac}$$

and $\Delta^2 \eta_p = \Delta^2 y_p + \frac{c}{p} P_p$

in which $\eta_p = y_p - \frac{c}{p} [pS_{p-1} + R_{p-1}]$

In the case of hinged elastically supported ends, the following equation is valid:

$$P_p = A(y_p - \delta_0)$$

where A is the force giving any elastic support a deflection of unity, and δ_0 is the lateral movement of the left end, that is, for $p=0$.

Now buckling of the bar is possible in two distinct ways. In the case of symmetric buckling, whereby $\delta_0 = \delta_n$, the following conditions are valid:

For $p=0$ and $p=n$, it follows that $y_0 = y_n = 0$ and $\eta_0 = \eta_n = 0$ and also $\Sigma P_p = 0$ or, consequently, $\Sigma(y_p - \delta_0) = 0$.

In the case of reversed symmetric buckling $\delta_0 = -\delta_n$.

In this case $y_0 = 0$; $y_n = 2\delta_0$, and it follows that $\eta_0 = \eta_n = 0$, furthermore $c\Sigma pP_p = 2P\delta_0$.

After several reductions the buckling condition is finally obtained, which can be written in both cases in the general form:

$$\frac{[A]}{[B]} = \frac{[C]}{[D]}$$

in which, in the case of symmetric buckling:

$$\begin{aligned} [A] &= \cosh(n+1)\psi - \cosh(n+1)\phi + \cosh\psi \cos n\phi - \cosh n\psi \cos\phi \\ [B] &= \sinh n\psi \sin\phi - \sinh\psi \sinh n\phi \end{aligned}$$

and in the case of reversed symmetric buckling:

$$\begin{aligned} [A] &= \cosh(n+1)\psi + \cos(n+1)\phi - \cosh\psi \cos n\phi - \cosh n\psi \cos\phi \\ [B] &= +\sinh n\psi \sin\phi + \sinh\psi \sin n\phi \end{aligned}$$

while in both cases:

$$\begin{aligned} [C] &= [2(\cosh\psi - \cos\phi)]^2 + 2B[\cosh\psi \cos\phi - 1] \\ [D] &= 2B \sinh\psi \sin\phi \end{aligned}$$

In these formulae ψ and ϕ are given by

$$\begin{aligned} \cos\phi &= -\frac{1}{4}\sqrt{\beta} + \frac{1}{4}\sqrt{\beta + 4\alpha + 16} \\ \cosh\psi &= +\frac{1}{4}\sqrt{\beta} + \frac{1}{4}\sqrt{\beta + 4\alpha + 16} \end{aligned}$$

in which:

$$\begin{aligned} \alpha &= B \left[\frac{m}{\pi} \sin \frac{\pi}{m} - 1 \right] - 2 \left[1 - \cos \frac{\pi}{m} \right] \\ \beta &= 2B \left[1 - \cos \frac{\pi}{m} \right] \end{aligned}$$

m representing the coefficient of virtual buckling length defined by the formula:

$$P = \frac{\pi^2 E \tau I}{m^2 c^2}$$

whilst furthermore

$$B = \frac{A m^2 c^3}{\pi^2 E \tau I} = \frac{m^2}{Y}$$

so that

$$Y = \frac{\pi^2 E \tau I}{A c^3}$$

In these equations:

- A = the force required for giving any elastic support a deflection of the unity (1 cm.);
- n = the number of panels of the strut;
- c = the length of a panel of the strut;
- $E\tau$ = modulus of buckling;
- I = the moment of inertia valid for the buckling direction under consideration.

In this way the most general expressions for buckling condition are given; they are valid in any given number of panels.

ψ and ϕ , however, can be eliminated in a fairly simple manner, and, for any given value of n in each particular case of buckling, two equations of higher degree in terms of B as a function of m , are obtained, viz. one in the case of symmetric buckling and the other in the case of reversed symmetric buckling. With

$$a = \left(1 - \frac{m}{\pi} \sin \frac{\pi}{m}\right) \quad b = 2 \left(1 - \cos \frac{\pi}{m}\right)$$

the values are found as follows:

where $n=2$:

symmetric buckling:
$$B = \frac{3b-6}{b-2a}$$

reversed symmetric buckling:

$$B = 1 \dots (\text{fig. 9})$$

where $n=4$:

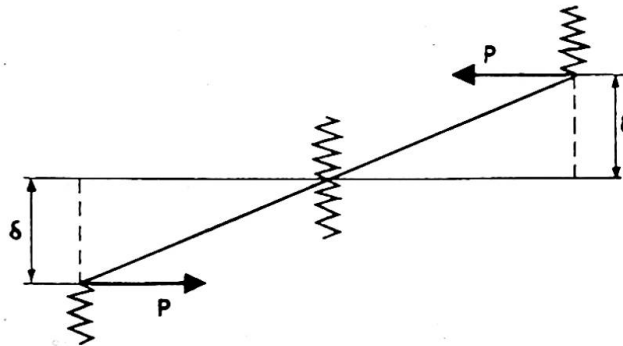

Fig. 9

symmetric buckling: $B^2(b^2 - 4ab + 2a^2) - B(5b^2 - 7ab - 13b + 10a) + (5b^2 - 20b + 10) = 0$

reversed symmetric buckling: $B^2(b^2 - 2ab) + B(ab + 5b - 3b^2) + (b^2 - 2b) = 0$

where $n=6$:

symmetric buckling: $B^3(b^3 - 6ab^2 + 9a^2b - 2a^3) + B^2(-7b^3 + 19b^2 - 52ab - 11a^2b + 14a^2 + 23ab^2) + B(14b^3 - 68b^2 - 16ab^2 + 70b + 56ab - 28a) + (-7b^3 + 42b^2 - 63b + 14) = 0$

reversed symmetric buckling: $B^3(3a^2b - 4ab^2 + b^3) + B^2(-a^2b + 9ab^2 - 5b^3 - 14ab + 11b^2) + B(-2ab^2 + 6b^3 + 4ab - 22b^2 + 14b) + (-b^3 + 4b^2 - 3b) = 0$

The accompanying two graphs (figs. 10 and 11) give the results, established point by point, for m ascending by 0.1, where $n=4$ and $n=6$. All roots have been determined, so that curves for all wave forms could be plotted. It will appear that in each case only two wave forms are possible. The other wave forms are fairly possible, but can only be produced "with assistance." Table V gives the maximum B values as a function of m for $n=4$ and $n=6$, whilst Table VI represents a set of buckling stresses determined in accordance with V.O.S.B. requirements (Netherl. Standards for the Designing of Steel Bridges), the admissible compressive stresses and safety factor given as functions of the ratio of slenderness λ , λ ascending from unity. In calculating the rigidity of the elastic supports (determination of A), the two deformation possibilities of the cross-section of the low-truss bridge are to be taken into account.

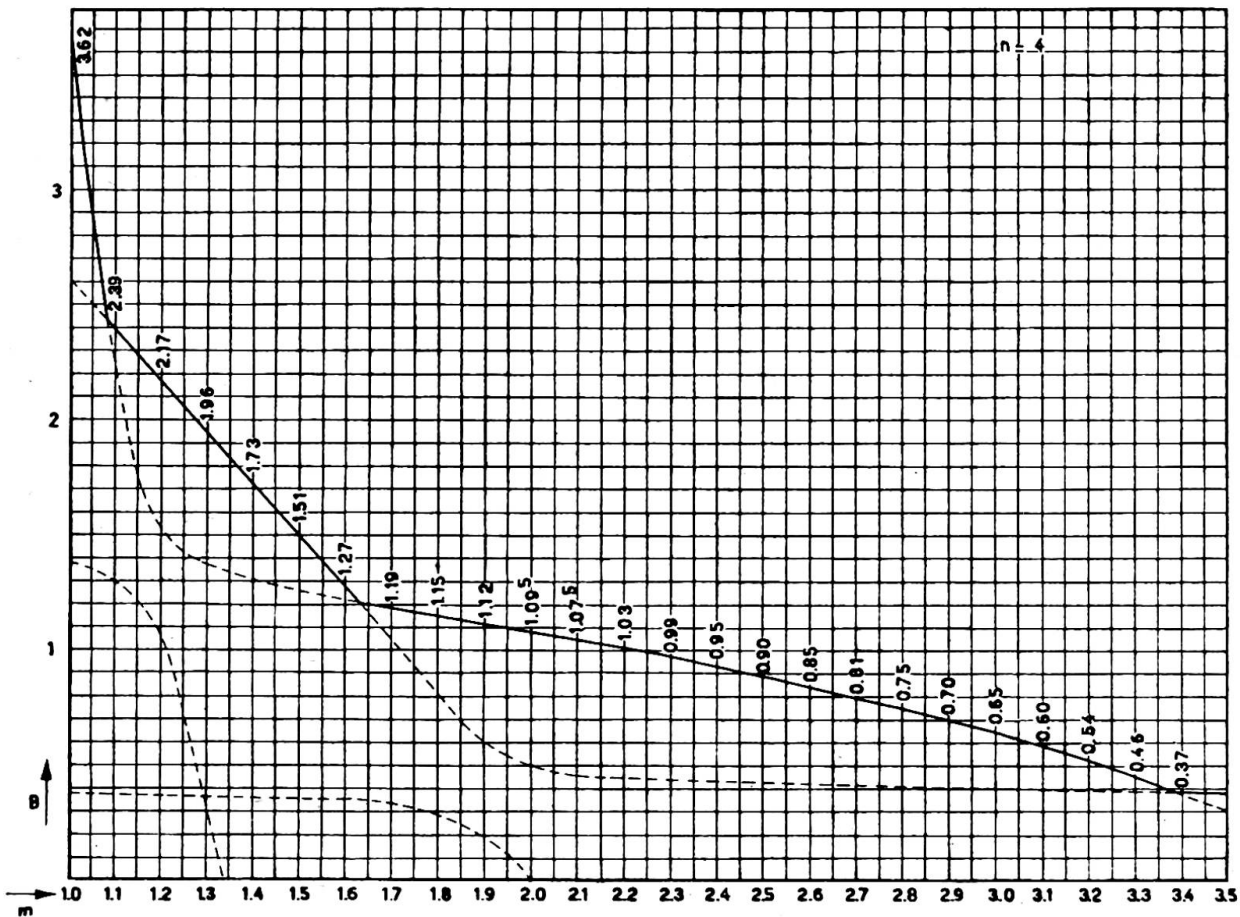

Fig. 10

The following formula is recommended (fig. 12):

$$A = \frac{1}{\frac{(a + \frac{1}{3}h_1)^3}{3EI_{II}} + \frac{(H - \frac{1}{2}h_2)^2 b}{2EI_I}}$$

How can the theory given above be applied? One possibility is to require the same safety factor in both the x and the y directions in the upper chord (the x axis is horizontal, the y axis is vertical). In general the radius of gyration with respect to the vertical axis (in this case, the y axis) will be larger than with respect to the x axis.

Then the following condition is valid:

$$\lambda_x = \lambda_y$$

hence

$$\frac{c}{i_x} = \frac{m \cdot c}{i_y}$$

so

$$m = \frac{i_y}{i_x}$$

The required value of B corresponding to m can then be found at once in Table V, hence:

$$A = \frac{B \cdot P_{buckling}}{c} = \frac{B \cdot n \cdot P_{actual}}{c}$$

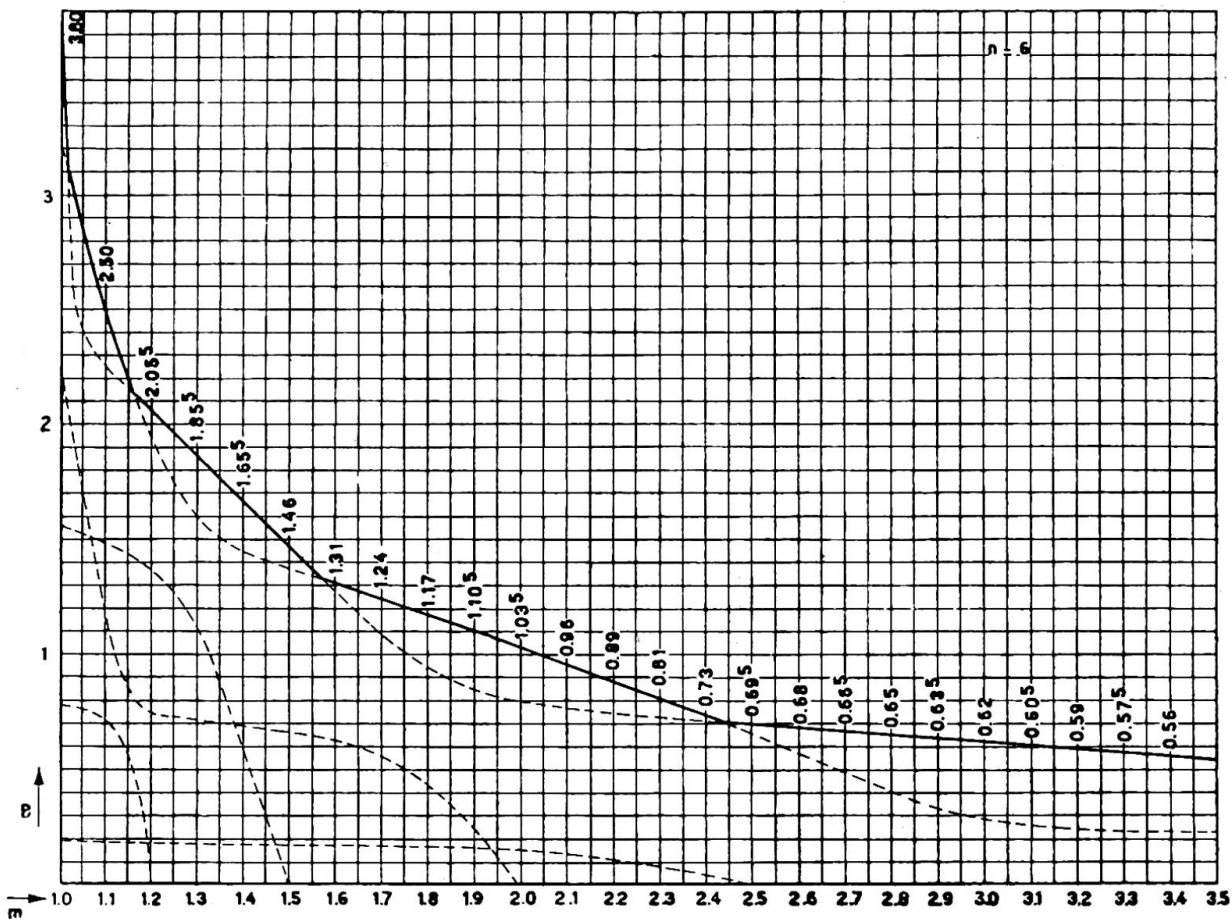

Fig. 11

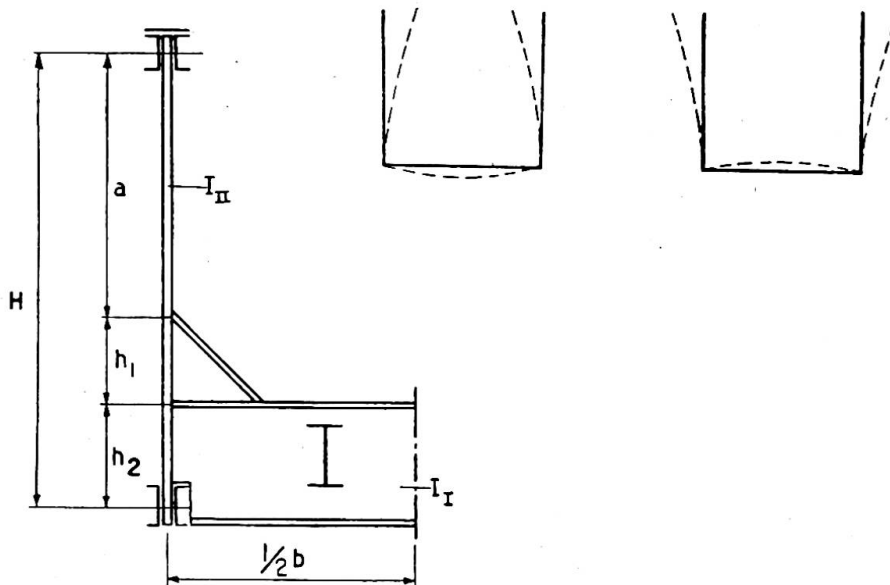

Fig. 12

n in this equation denotes the required coefficient of safety against buckling under the condition $\lambda_x = \lambda_y$. This value can at once be found in Table VI, where $\lambda_x = \lambda_y$ is known, which will obviously be the case.

The ratio $m = i_y/i_x$ will generally be fairly small, varying between about 1 and 1.5, and will seldom be more. The corresponding values of B are then usually rather high, so that rigid vertical members are required in order to ensure the same resistance against buckling with respect to both x and y axis. This, particularly in the case of high bridges without upper bracing, leads to heavy constructions. In such cases it will be found more advantageous to construct the upper chord somewhat heavier with regard to the y direction, considering the last direction decisive (the x direction being safe). The procedure then is as follows.

The actual compressive stress is given by:

$$\sigma_d = \frac{P_{actual}}{F}$$

where F is the gross cross-sectional area of the upper chord; Table VI at once gives the corresponding required ratio of slenderness with respect to the y axis. This value being λ_y , the required m value will be:

$$m = i_y \cdot \frac{\lambda_y}{c}$$

The corresponding value of B can now be found in Table V; moreover:

$$A = \frac{B \cdot n \cdot P_{actual}}{c}$$

n denoting the required factor of safety against buckling according to λ_y , also to be found in Table VI.

The most advantageous use of material can, of course, only be found by trial, that is, by comparing various possibilities with regard to their total weight.

TABLE V

m	B		m	B	
	$n=4$	$n=6$		$n=4$	$n=6$
1.0	3.62	3.80	2.3	0.99	0.81
1.1	2.39	2.50	2.4	0.95	0.73
1.2	2.17	2.05 ⁵	2.5	0.90	0.69 ⁵
1.3	1.96	1.85 ⁵	2.6	0.85	0.68
1.4	1.73	1.65 ⁵	2.7	0.81	0.66 ⁵
1.5	1.51	1.46	2.8	0.75	0.65
1.6	1.27	1.31	2.9	0.70	0.63 ⁵
1.7	1.19	1.24	3.0	0.65	0.62
1.8	1.15	1.17	3.1	0.60	0.60 ⁵
1.9	1.12	1.10 ⁵	3.2	0.54	0.59
2.0	1.09 ⁵	1.03 ⁵	3.3	0.46	0.57 ⁵
2.1	1.07 ⁵	0.96	3.4	0.37	0.56
2.2	1.03	0.89	3.5	0.37	0.54 ⁵

Method of calculation

Calculate $\sigma = P/F$. Find in Table VI the required ratio of slenderness λ_y , corresponding to σ . Hence:

$$m = \frac{\lambda_y i_y}{c}$$

i_y being the radius of gyration with respect to the y axis and c being the length of a panel. Then in Table V the corresponding value B to m can be found. Now, σ_k corresponding to λ_y also known in Table VI, A can be calculated according to

$$A = \frac{B \cdot P_{buckling}}{c}$$

so here

$$P_{buckling} = F \cdot \sigma_k$$

TABLE VI

λ	σ_k	n	σ_d	λ	σ_k	n	σ_d	λ	σ_k	n	σ_d	λ	σ_k	n	σ_d
0-30	2400	1.714	1400	73	2276	2.52	904	116	1539	3.5	440	159	820	3.5	234
	2380	1.700													
31	2379	1.713	1388	74	2272	2.55	892	117	1515	„	432	160	810	„	231
32	2377	1.726	1377	75	2268	2.58	880	118	1490	„	425	161	800	„	228
33	2376	1.740	1365	76	2263	2.61	869	119	1465	„	417	162	790	„	226
34	2375	1.754	1354	77	2259	2.63	857	120	1440	„	411	163	781	„	223
35	2374	1.769	1342	78	2254	2.66	846	121	1415	„	404	164	771	„	220
36	2373	1.782	1331	79	2250	2.69	834	122	1392	„	397	165	761	„	217
37	2372	1.798	1319	80	2245	2.73	823	123	1370	„	391	166	752	„	215
38	2370	1.811	1308	81	2239	2.76	809	124	1347	„	385	167	743	„	212
39	2369	1.827	1296	82	2234	2.80	800	125	1327	„	379	168	735	„	210
40	2368	1.844	1284	83	2229	2.83	788	126	1307	„	373	169	726	„	208
41	2366	1.858	1273	84	2223	2.87	777	127	1286	„	367	170	717	„	205
42	2364	1.874	1261	85	2218	2.90	765	128	1266	„	361	171	709	„	203
43	2362	1.890	1250	86	2211	2.94	753	129	1245	„	355	172	701	„	201
44	2361	1.907	1238	87	2205	2.98	741	130	1228	„	350	173	692	„	198
45	2359	1.922	1227	88	2198	3.01	730	131	1207	„	345	174	684	„	196
46	2357	1.940	1215	89	2192	3.05	719	132	1189	„	340	175	676	„	193
47	2355	1.958	1204	90	2185	3.09	707	133	1171	„	335	176	669	„	191
48	2353	1.975	1191	91	2176	3.13	694	134	1155	„	330	177	662	„	189
49	2352	1.993	1180	92	2167	3.16	684	135	1137	„	325	178	654	„	187
50	2350	2.011	1169	93	2158	3.20	673	136	1122	„	320	179	647	„	185
51	2347	2.028	1157	94	2149	3.25	661	137	1103	„	315	180	640	„	183
52	2344	2.045	1146	95	2140	3.29	650	138	1080	„	309	181	633	„	181
53	2341	2.064	1134	96	2125	3.33	638	139	1072	„	305	182	626	„	179
54	2338	2.082	1123	97	2110	3.36	627	140	1056	„	301	183	619	„	177
55	2335	2.10	1111	98	2095	3.40	615	141	1043	„	297	184	612	„	175
56	2332	2.12	1100	99	2080	3.44	603	142	1027	„	293	185	605	„	173
57	2329	2.14	1085	100	2065	3.48	592	143	1014	„	289	186	599	„	171
58	2326	2.16	1077	101	2028	3.50	580	144	998	„	285	187	593	„	169
59	2323	2.18	1065	102	1990	3.50	569	145	985	„	282	188	587	„	167
60	2320	2.20	1054	103	1954	„	558	146	971	„	278	189	581	„	166
61	2317	2.22	1042	104	1917	„	547	147	958	„	274	190	575	„	164
62	2314	2.25	1031	105	1880	„	536	148	945	„	270	191	569	„	163
63	2311	2.27	1021	106	1845	„	527	149	934	„	267	192	563	„	161
64	2308	2.30	1007	107	1881	„	517	150	921	„	263	193	557	„	159
65	2305	2.32	994	108	1777	„	507	151	909	„	259	194	551	„	157
66	2302	2.34	984	109	1751	„	500	152	897	„	256	195	545	„	156
67	2299	2.36	973	110	1714	„	490	153	886	„	253	196	540	„	154
68	2296	2.39	960	111	1682	„	480	154	874	„	249	197	534	„	153
69	2293	2.41	952	112	1653	„	472	155	862	„	246	198	529	„	151
70	2290	2.44	938	113	1623	„	469	156	852	„	243	199	523	„	149
71	2286	2.46	927	114	1593	„	546	157	841	„	240	200	518	„	148
72	2281	2.49	915	115	1566	„	447	158	831	„	237			„	

Numerical example.

B No. 425 low-truss bridge of the State Railways in the former Netherlands Indies; theoretical length 6×435 cm. Trapezoidal main girder. Upper chord extending over four panels.

The data then are:

$$n=4; c=435 \text{ cm.}; i_y=14.7 \text{ cm.};$$

$$F=178.6 \text{ cm.}^2 \text{ (gross cross-sectional area of upper chord);}$$

$$P_{max}=-141 \text{ metric tons (having } A=0.550 \text{ metric tons/cm.);}$$

$$\text{Actual compressive stress } \sigma_d = \frac{141}{178.6} = 0.789 \text{ metric tons/cm.}^2;$$

Corresponding ratio of slenderness found in Table VI, $\lambda_y=92$.

Required coefficient of virtual buckling length:

$$m = \frac{92 \times 14.7}{435} = 3.1$$

In Table V is found $B=0.604$ according to $n=4$ and $m=3.1$. To $\lambda_y=92$ corresponds $\sigma_k=2,140$, hence $P_{buckling}=178.6 \times 2,140=382$ metric tons (Table VI).

$$\text{Required: } A = \frac{0.604 \times 382}{485} = 0.530 \text{ metric tons/cm.}$$

Having $A=0.550$ metric tons/cm., the actual factor of safety is therefore somewhat larger than calculated.

Summary

This paper deals with the results of a theoretical study of two cases of buckling, both of them under application of the theory of equations of finite differences.

The first case refers to the buckling of latticed struts with long battens only, the lengths not being neglected. It proved possible to deduce an exact buckling condition, in which all extreme cases are unequivocally included.

The second case deals with the buckling of bars elastically supported at any number of intermediate and equidistant points, while the two end supports are also elastic, permitting lateral movement and having the same rigidity as the others. In this case also it proved possible to deduce an exact buckling condition valid for any given number of panels.

Both cases are documented with graphs, tables and calculation methods, enabling easy application in practice. Two numerical examples are given by way of illustration.

For detailed information see: Ir. W. J. van der Eb, "Over enige bijzondere knikgevallen," Rapport No. 21: Commissie inzake Onderzoek van Constructies T.N.O., Postbox 49, Delft Nederland.

Résumé

L'auteur expose une recherche théorique sur deux cas de flambage, effectuée en appliquant le calcul des différentielles finies aux deux cas.

Le premier cas porte sur le flambage des barres en treillis, avec éléments d'assemblage relativement longs dans le sens de la longueur de la barre. On a pu arriver à une condition de flambage exacte, qui englobe sans équivoque tous les cas extrêmes.

Le second cas porte sur le flambage de barres supportées latéralement par un nombre quelconque d'étais concentrés élastiques et équidistants, les deux étais d'extrémité étant également élastiques, c'est-à-dire latéralement déplaçables et de la

même rigidité que les autres. Ici encore, on a pu établir une condition de flambage valable pour n'importe quel nombre de panneaux.

Les deux cas sont complétés par des graphiques, tableaux et méthodes de calcul, permettant une application simple en pratique. Deux calculs sont effectués à titre d'exemples.

Pour l'étude détaillée, voir: Ir. W. J. van der Eb, "Over enige bijzondere knikgevallen," Rapport No. 21: Commissie inzake Onderzoek van Constructies T.N.O., Postbox 49, Delft, Nederland.

Zusammenfassung

Im vorstehenden Aufsatz wird das Endergebnis einer theoretischen Abhandlung über zwei Knickfälle unter Anwendung der Differenzrechnung näher untersucht.

Der erste Fall bezieht sich auf die Knickung von Rahmenstäben mit in der Stabrichtung verhältnismässig langen Bindeblechen. Es gelang, eine exakte Knickbedingung abzuleiten, in der alle extremen Fälle eindeutig eingeschlossen sind.

Im zweiten Fall handelt es sich um die Knickung von Stäben, die in einer beliebigen Anzahl gegenseitig gleichweit entfernter Zwischenpunkte elastisch quergestützt sind, wobei auch die beiden Endabstützungen elastisch, also seitlich verschieblich sind und gleiche Steifigkeit wie die übrigen Abstützungen aufweisen sollen. Auch in diesem Fall gelang es, eine exakte und für beliebige Felderzahl gültige Knickbedingung abzuleiten.

In beiden Fällen wird die praktische Anwendung durch graphische Darstellungen, Tabellen und Rechenvorschriften, sowie zwei numerische Beispiele erleichtert.

Die vollständige Abhandlung einschliesslich allen Zwischenrechnungen ist zu finden in: Ir. W. J. van der Eb, "Over enige bijzondere knikgevallen," Rapport No. 21: Commissie inzake Onderzoek van Constructies T.N.O., Postbox 49, Delft, Nederland.