

Some formworks for concrete arch bridges

Autor(en): **Enskog, Georg**

Objektyp: **Article**

Zeitschrift: **IABSE congress report = Rapport du congrès AIPC = IVBH
Kongressbericht**

Band (Jahr): **5 (1956)**

PDF erstellt am: **22.07.2024**

Persistenter Link: <https://doi.org/10.5169/seals-6135>

Nutzungsbedingungen

Die ETH-Bibliothek ist Anbieterin der digitalisierten Zeitschriften. Sie besitzt keine Urheberrechte an den Inhalten der Zeitschriften. Die Rechte liegen in der Regel bei den Herausgebern.

Die auf der Plattform e-periodica veröffentlichten Dokumente stehen für nicht-kommerzielle Zwecke in Lehre und Forschung sowie für die private Nutzung frei zur Verfügung. Einzelne Dateien oder Ausdrucke aus diesem Angebot können zusammen mit diesen Nutzungsbedingungen und den korrekten Herkunftsbezeichnungen weitergegeben werden.

Das Veröffentlichen von Bildern in Print- und Online-Publikationen ist nur mit vorheriger Genehmigung der Rechteinhaber erlaubt. Die systematische Speicherung von Teilen des elektronischen Angebots auf anderen Servern bedarf ebenfalls des schriftlichen Einverständnisses der Rechteinhaber.

Haftungsausschluss

Alle Angaben erfolgen ohne Gewähr für Vollständigkeit oder Richtigkeit. Es wird keine Haftung übernommen für Schäden durch die Verwendung von Informationen aus diesem Online-Angebot oder durch das Fehlen von Informationen. Dies gilt auch für Inhalte Dritter, die über dieses Angebot zugänglich sind.

VI a 1

Some formworks for concrete arch bridges

Einige Lehrgerüste für Betonbogenbrücken

Alguns cimbres de pontes em arco de betão

Quelques cintres de ponts-arc en béton

GEORG ENSKOG

Bromma

During 1951-1952 a concrete railway bridge was built in Northern Sweden with an arch span of 112 m, designed by the construction office of the Royal Board of Swedish State Railways.

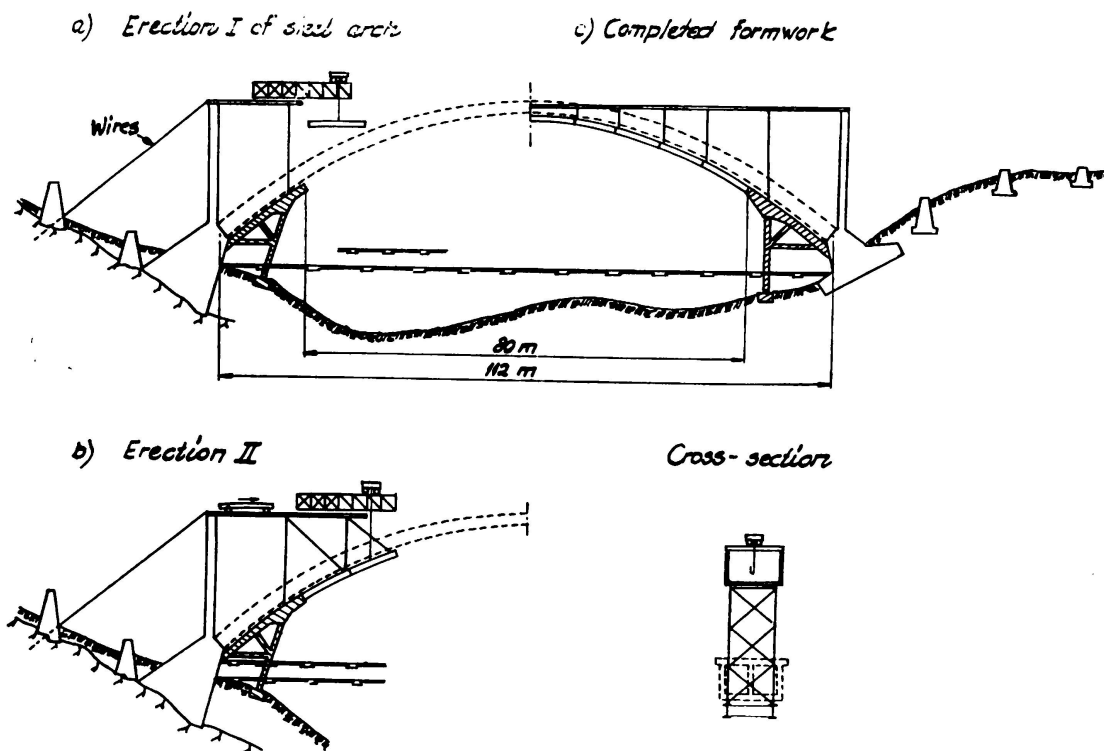

FIG. 1. Formwork for a 112 m concrete arch

For several reasons no supports for the falsework could be placed in the deep parts of the river. Up to a distance of 15 m from the abutments, the shuttering for the arch rested on provisional concrete falseworks which were, at the same time, abutments for a steel arch with a span of 80 m. This all-welded arch constituted the rest of the formwork. For the erection of the steel arch an I-beam structure was placed on the permanent abutment-column and on a steel support, resting on the provisional concrete falsework. It was anchored back on wires

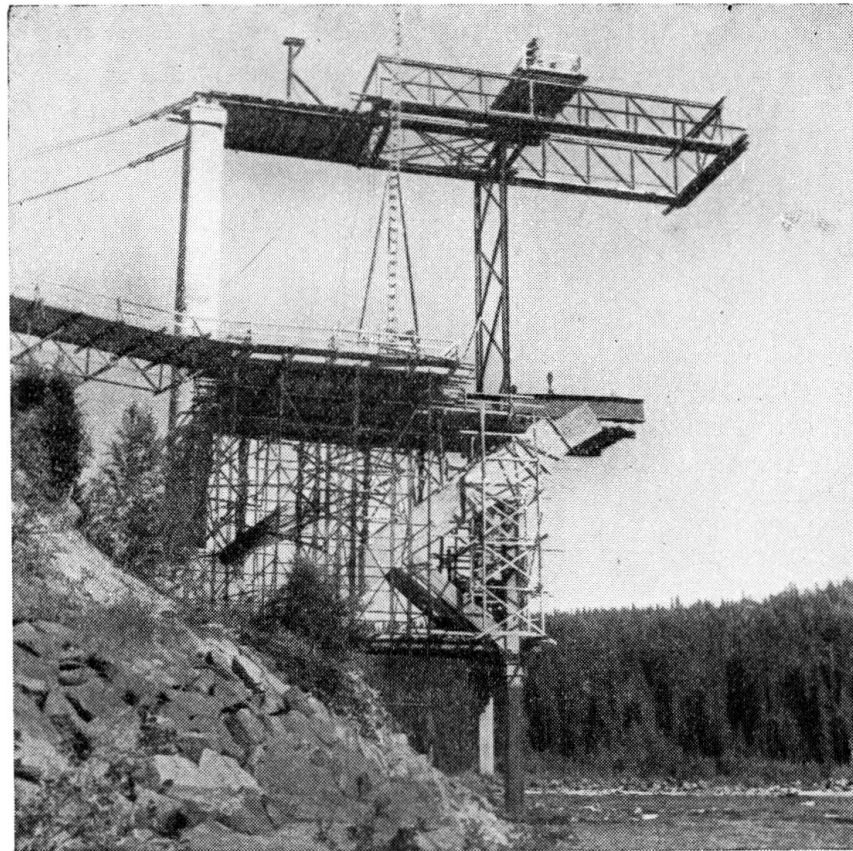

FIG. 2. Erection of steel arch

as shown in fig. 1. Upon this upper structure a light bridge, provided with a travelling hoist, was mounted. The first elements of the steel arch, about 10 m long, were taken to the upper structure, placed under the travelling hoist and finally lowered into position and bolted to the concrete structure, fig. 2. After inserting the diagonals, a new vertical support was erected and the upper I-beam structure extended. The mobile bridge could now be pushed forward and the former procedure repeated. Before moving this bridge forward again, the points between the arch

elements were welded. After completing the erection of the steel arch, the anchoring wires and the diagonals were taken away.

The upper I-beam structure was later used for transporting materials when concreting the arch span and was finally used as a support when the superstructure was built.

After finishing the concrete work the steel arch was cut at the welded joints and stored. It has been used again later on for building an identical concrete arch in another place.

The designer of the falsework was docent S. Kasarnowsky.

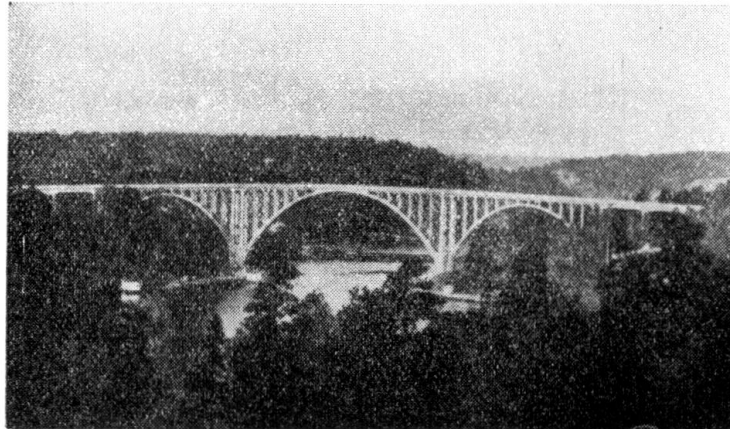

FIG. 3. The Skuru bridge, constructed in 1914-1915

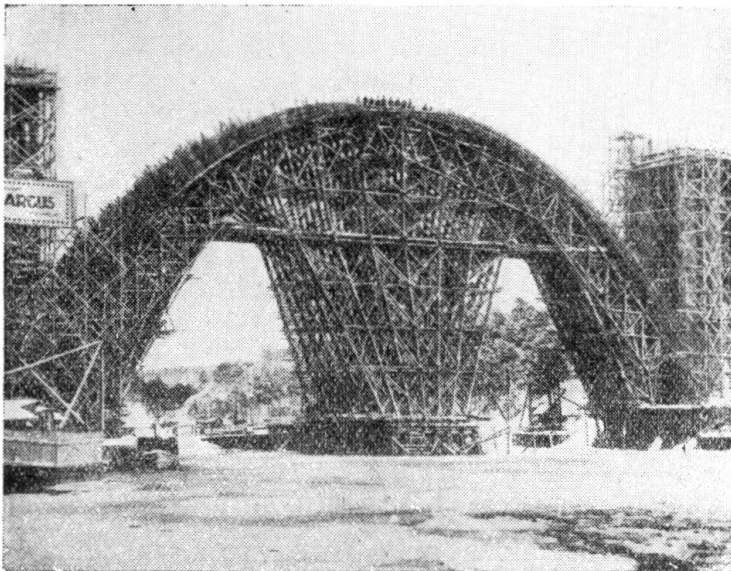

FIG. 4. Fan-shaped scaffolding 1914

Some 40 years ago, one of the largest concrete bridges of that time was built over the Skuru Sound near Stockholm. It has a total length

of 280 m and a main span of 72 m, fig. 3. This beautiful bridge, however, has proved too narrow for the increasing traffic. An identical bridge has therefore been built alongside the former one to be used for traffic in one direction, the old bridge, together with a new dilated roadway, taking the traffic in the other direction.

In 1914 a fan-shaped timber scaffolding for the main arch was used, taking a large amount of wood and working hours, fig. 4. In 1954

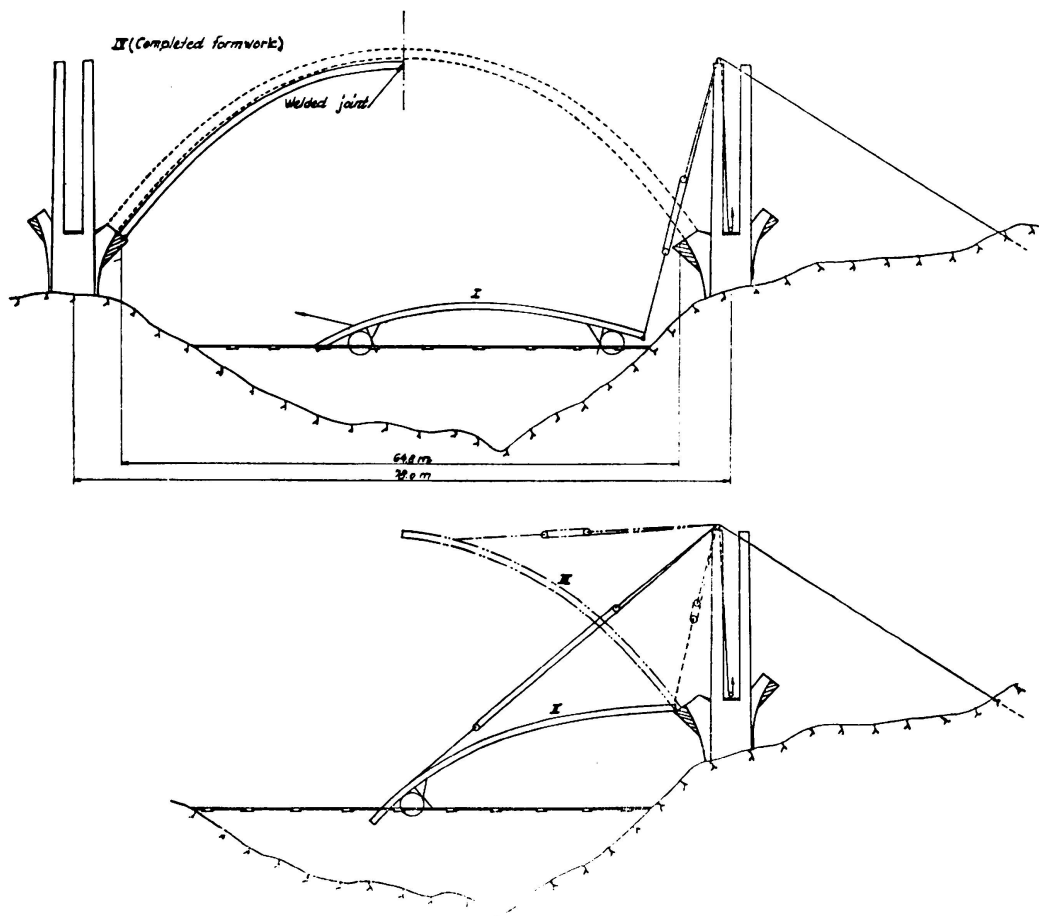

FIG. 5. Erection of falsework

another solution had to be found. Again welded steel arches were used. They were shop assembled in two halves and towed to the site. At the site both halves were lifted at the abutment ends to provisional hinges and then hoisted into final position as shown in fig. 5 and 6. Here again the abutment columns had to be concreted before the erection of the steel arches.

Designers of the bridge and falsework were Nya Asfalt AB, Stockholm, contractors of those bridges. The Royal Swedish Board of Roads and Waterways projected the new Skuru bridge.



FIG. 6. First part of the arch in its final position, the second being hinged at the abutment

SUMMARY

The author describes the formwork for a 112 m concrete arch with no provisional supports in the river.

Falseworks for a 72 m arch of a bridge built in 1914 and for an identical arch built in 1954 are also described.

ZUSAMMENFASSUNG

Beschreibung des Lehrgerüsts für einen Betonbogen von 112 m Spannweite, der den Fluss ohne Zwischenstützen überspannt.

Lehrgerüst für einen Bogen von 72 m einer Brücke aus dem Jahre 1914 sowie für einen gleichen Bogen, der im Jahre 1954 erbaut wurde.

RESUMO

O autor descreve a cofragem de um arco de 112 m. de vão, construído sem auxílio de apoios intermédios no rio.

Também descreve os cimbrês de um arco de 72 m de uma ponte construída em 1914 e de um arco idêntico construído em 1954.

R É S U M É

L'auteur décrit le coffrage d'un arc de 112 m. de portée, construit sans appuis provisoires dans la vallée.

Les cintres d'un arc de 72 m d'un pont construit en 1914 et d'un arc identique construit en 1954 sont également décrits.