

# New developments in Dutch steel bridge building

Autor(en): **Ypeij, E.**

Objektyp: **Article**

Zeitschrift: **IABSE congress report = Rapport du congrès AIPC = IVBH  
Kongressbericht**

Band (Jahr): **9 (1972)**

PDF erstellt am: **21.07.2024**

Persistenter Link: <https://doi.org/10.5169/seals-9634>

## **Nutzungsbedingungen**

Die ETH-Bibliothek ist Anbieterin der digitalisierten Zeitschriften. Sie besitzt keine Urheberrechte an den Inhalten der Zeitschriften. Die Rechte liegen in der Regel bei den Herausgebern.

Die auf der Plattform e-periodica veröffentlichten Dokumente stehen für nicht-kommerzielle Zwecke in Lehre und Forschung sowie für die private Nutzung frei zur Verfügung. Einzelne Dateien oder Ausdrucke aus diesem Angebot können zusammen mit diesen Nutzungsbedingungen und den korrekten Herkunftsbezeichnungen weitergegeben werden.

Das Veröffentlichen von Bildern in Print- und Online-Publikationen ist nur mit vorheriger Genehmigung der Rechteinhaber erlaubt. Die systematische Speicherung von Teilen des elektronischen Angebots auf anderen Servern bedarf ebenfalls des schriftlichen Einverständnisses der Rechteinhaber.

## **Haftungsausschluss**

Alle Angaben erfolgen ohne Gewähr für Vollständigkeit oder Richtigkeit. Es wird keine Haftung übernommen für Schäden durch die Verwendung von Informationen aus diesem Online-Angebot oder durch das Fehlen von Informationen. Dies gilt auch für Inhalte Dritter, die über dieses Angebot zugänglich sind.

### New Developments in Dutch Steel Bridge Building

Nouveaux développements dans la construction des ponts en acier dans les Pays-Bas

Neue Entwicklungen im Stahlbrückenbau in den Niederlanden

ir. E. YPEIJ  
Chief Engineer  
Directie Bruggen  
Rijkswaterstaat, Netherland

In order to overcome the influences of the ever increasing wages on the total costs of the construction of steel bridges various changes have been adopted in the design taking into account the following principles:

1. Increasing the number of identical items to be used in the bridges.
2. Minimising the number of items with which a bridge should be built.

These changes can be illustrated with the following examples.

#### Steel bridges with a light-weight concrete deck.

Across the new Scheldt-Rhine canal and the Amsterdam-Rhine canal a number of new bridges have to be built.

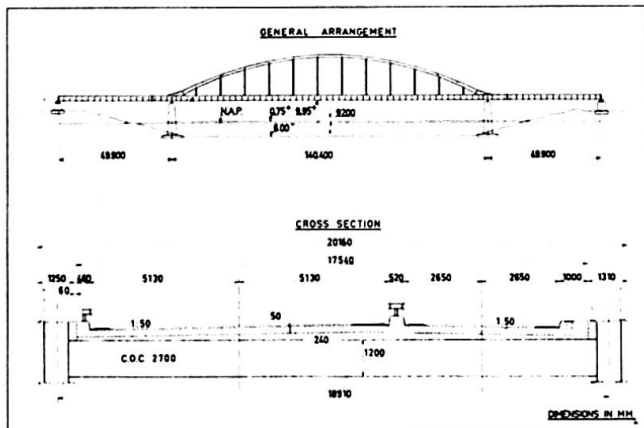

figure 1.

Various designs have been made for these canal crossings, as well in concrete as in steel. After considering the designs, both from technical and economical points of view, the "bowstring" type has been chosen for the main-girders. This also, because such a type of bridge requires a small constructional height (the distance between the upper side of the bridge-deck and the under side of the steel structure) which is of great importance for the approaches. The bridge-deck is a composite construction, consisting of a light-weight concrete deck acting in co-operation with the cross-girders. The deck has not any stringers. The cross-girders are placed 2.70 metres c.o.c. and are I beams provided with studs on the top flange and having only provisions at the ends for the connection to the main-girders.

The use of light-weight concrete for the bridge-deck has given a weight saving of appr. 700 tons in the bridge-deck which in turn gave an additional saving of 120 tons in steel material for the main-girders.

The first bridge completed in this type of construction is the bridge across the Scheldt-Rhine canal near Tholen (figure 1.). The light-weight aggregate used for the concrete consists of "Korlin" a product of the D.S.M. (Dutch States Mines) having a specific grain weight of 1.19 to 1.23 and a water absorption of 3%.

Since only the heavy aggregate in the concrete was replaced by the light-weight aggregate the specific weight of the concrete in the deck was in average 1780 kgf/m<sup>3</sup>. The cube strength after 28 days was in average 350 kgf/cm<sup>2</sup>.

Push out tests.

In order to investigate the carrying capacity of the studs in light-weight concrete, special tests have been performed. The test specimen consisted of a steel plate with a thickness of 30 mm steel quality Fe 37 and light-weight concrete blocks connected to the plate at each side with the use of 4 studs (figure 4). Special precautions were taken to reduce secondary influences as much as possible.

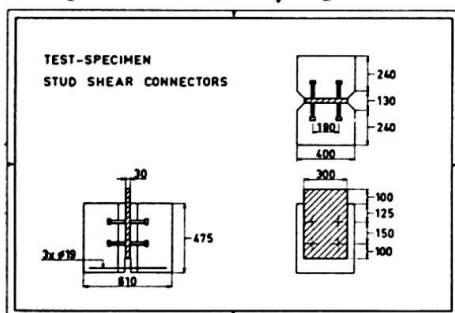

figure 2.

The following test specimen were used:

<u>Specimen number</u>	<u>stud diameter</u> <u>in mm's</u>	<u>stud length</u> <u>in mm's</u>	<u>spiral around</u> <u>studs</u>
A1 A2 and A3	22	110	yes
B1 B2 and B3	22	132	yes
C1 C2 and C3	22	154	yes
D1 D2 and D3	22	110	no
E1 E2 and E3	22	132	no
F1 F2 and F3	22	154	no
G1 G2 and G3	20	100	no
H1 H2 and H3	20	120	no
I1 I2 and I3	20	140	no

The aggregate used in the light-weight concrete was a mixture of sand and Berwilit, an expanded slate product. The specific weight of the concrete was in average 1760 kgf/m<sup>3</sup>, the cube strength in average 345 kgf/cm<sup>2</sup> and the cleave strength in average 26 kgf/cm<sup>2</sup>.

The material used for the studs was Fe 37.

The results of the tests are given in table 1.

A comparison of the test results with the design values of the allowable loads on studs in normal concrete is given in table 2. In this table, S means the safety factor of the allowable load according to the mentioned standards as compared to the ultimate load as found in the test.

Test-specimen	COMPARISON OF TEST-RESULTS WITH DESIGN VALUES AS GIVEN IN FOREIGN STANDARDS.					
	P <sub>0,1</sub> per stud (t)	P <sub>ultimate</sub> per stud (t)	Design values in tons			
			Austrian standard		British standard CP-117:2	
			Bridges	S	Bridges	S
A	14,9(13,2)	20 (19,3)	4,53	4,4	-	-
B	14,9(14,0)	19,3(19,0)	4,53	4,2	-	-
C	13,4(13)	19,5(18,4)	4,53	4,1	-	-
D	9,1(8,3)	15,1(14,5)	3,60	4,2	3,70	4,1
E	8,6(7,3)	14,8(14,3)	3,60	4,1	-	-
F	7,9(7,5)	13,3(11,7)	3,60	3,7	-	-
G	6,8(6,2)	14,5(14,4)	2,95	4,9	2,95	4,9
H	7,1(6,9)	13,3(11,8)	2,95	4,4	-	-
I	7,7(7,0)	12,1(10,8)	2,95	4,1	-	-

\*BETWEEN BRACKETS THE LOWEST VALUE PER SERIE.

table 2.

For the calculation of the allowable loads, the values for the cube strength as given in table 1 are taken into account. The used formulae as given in

the provisional Austrian Standard (1) are:

studs with spirals  $P_{allow.} = 50 d^2 \sqrt{K_{28}}$  ;

studs without spirals  $P_{allow.} = 40 d^2 \sqrt{K_{28}}$

in these formulae  $K_{28}$  means the cube strength after 28 days.

These formulae are deduced from the allowable loads per stud as given in the A.A.S.H.O.(2) and are based on a safety factor of 4 against the ultimate load. It can be seen that this required safety factor is also found in the tests with the light-weight concrete and furthermore that this safety factor is decreasing when the length of the stud is increased.

RESULTS PUSH-OUT TESTS								
Test-specimen	Stud diameter (mm)	Stud length (mm)	Cube-strength $K_{28}$	$P_{0,1}$ (t)	$P_{0,1}$ aver. (t)	P ultimate (t)	$P_{ult}$ aver. (t)	$\frac{P_{ult}}{P_{0,1}}$
A <sub>1</sub> (S)	22	110	350 kgf/cm <sup>2</sup>	128	119,7	156	160	1,34
A <sub>2</sub> (S)	"	"		125		169		
A <sub>3</sub> (S)	"	"		106		155		
B <sub>1</sub> (S)	"	132		112,6	119,7	152,5	155	
B <sub>2</sub> (S)	"	"		127		156,5		
B <sub>3</sub> (S)	"	"		119,5		156		
C <sub>1</sub> (S)	"	154		104	107	151	148	
C <sub>2</sub> (S)	"	"		107		147,5		
C <sub>3</sub> (S)	"	"		110		147		
D <sub>1</sub>	22	110		345 kgf/cm <sup>2</sup>	74	72,5	123,5	
D <sub>2</sub>	"	"	77		123			
D <sub>3</sub>	"	"	66,5		116			
E <sub>1</sub>	"	132	76		68,8	116	118,8	
E <sub>2</sub>	"	"	72			126		
E <sub>3</sub>	"	"	58,5			114,5		
F <sub>1</sub>	"	154	60		63,5	114	106,6	
F <sub>2</sub>	"	"	69			112		
F <sub>3</sub>	"	"	61,5			94		
G <sub>1</sub>	20	100	340 kgf/cm <sup>2</sup>		57	54,7	115,5	116,2
G <sub>2</sub>	"	"		50,1	116			
G <sub>3</sub>	"	"		56,4	117			
H <sub>1</sub>	"	120		58	56,5	107	104,8	
H <sub>2</sub>	"	"		56,5		95		
H <sub>3</sub>	"	"		55,2		112,5		
I <sub>1</sub>	"	140		56,2	61,7	108	97,0	
I <sub>2</sub>	"	"		60,5		86,5		
I <sub>3</sub>	"	"		68,0		96,5		

Tests on cover-plated beams.(5)

In order to receive an economical use of the material it is a normal practise to increase the strength of beams, there where required. This is mostly done by placing additional flange plates to the base flanges of the beam. These additional flange plates are mostly welded to the base flanges.

Fatigue tests of beams constructed in this way show that failure nearly always appears in the area adjacent to the end of the welds. This is due to the fact that in this area the strain concentrations appear and that this zone is heat affected by the welding. The tests have shown also that the effect of special end

(S) = Stud with spiral reinforcement.  
 $P_{0,1}$  is the required load to receive a permanent displacement of 0,1 mm in the connection after unloading.

table 1.

details of the additional flange on the fatigue strength is rather small and does not justify their additional costs.

To improve the fatigue strength, the use of high strength bolts in co-operation with the fillets welds has been considered.

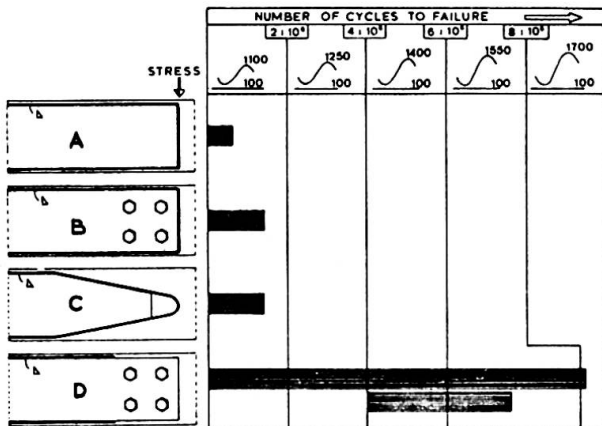

figure 3.

In fig.3 the details of the end connection of the additional flange plate of the tested beams are given as well as the number of cycles to failure and the magnitude of the maximum and minimum stress in the tested beam at the location of the end connection. The tested beams themselves had a length of 2.9 metres and were reinforced with additional flange plates over the middle 1.04 metres. The concentrated load was placed in the centre of the beam. The load cycles had a frequency of 5 Hz and were chosen in such a way that the maximum stress in the beam near the end of the additional plate

reached a value of 1100 kgf/cm<sup>2</sup> and the minimum stress a value of 100 kgf/cm<sup>2</sup>

cm<sup>2</sup>. In case the beam did not show any sign of failure after two million cycles, the maximum stress was raised with 150 kgf/cm<sup>2</sup> to 1250 kgf/cm<sup>2</sup> and so on. In all cases the minimum stress was 100 kgf/cm<sup>2</sup>.

The beams of the shape D were made in twofold.

The testing of the second beam of the shape D started at a maximum stress of 1400 kgf/cm<sup>2</sup> due to the fact that the first beam of this shape did not show any damages after more than two million cycles at the stress cycle of 1550 - 100 kgf/cm<sup>2</sup>.

The beams were IPE 40, the additional flanges have been cut to size with a cutting torch from a steel sheet of quality Fe 37.

The welds have been made with a Habilis 4mm electrode (ISO : E443 - T45).

The quality of the high strength bolts was 10K with nuts 8 G

(10K :  $R_m = 100 \text{ kgf/mm}^2$   $R_{0,2} = 90 \text{ kgf/mm}^2$ )(8G : HB = 353 kgf/mm<sup>2</sup>).

The diameter of the bolts was 20 mm, the pre-tension 17,1 tonf.

Neither the beam nor the plates did get any surface treatment.

In all cases cracks did occur near the welds with the exception of one of the beams D where the cracks started at the first bolt row.

First test type D:

1100 - 100 kgf/cm <sup>2</sup>	$2 \times 10^6$ cycles	no crack
1250 - 100 kgf/cm <sup>2</sup>	$2 \times 10^6$ cycles	no crack
1400 - 100 kgf/cm <sup>2</sup>	$2 \times 10^6$ cycles	no crack
1550 - 100 kgf/cm <sup>2</sup>	$3.3 \times 10^6$ cycles	no crack
1700 - 100 kgf/cm <sup>2</sup>	$1.4 \times 10^4$ cycles	crack

Second test type D:

1400 - 100 kgf/cm <sup>2</sup>	$2 \times 10^6$ cycles	no crack
1500 - 100 kgf/cm <sup>2</sup>	$1.6 \times 10^6$ cycles	crack

Although the number of tests made is not large enough to give a definite conclusion regarding the fatigue strength and the loading conditions in practice mostly differ from the type of loading used in these tests, it can be said that the correct use of high strength bolts in combination with welding gives a great improvement.

#### Steel bridges with steel decks.

A system of standardising the steel deck has been adopted in which the cross-girders are not directly welded to the steel deck. By doing this, the deck plate is only partly used as top flange for the cross-girders and therefore a slight increase in the quantity of steel is required.

The standard items of the steel deck consist of a steel plate with a width of 2.40 metres and 4 trough type stringers welded to this plate, the stringers being placed 0.60 metres c.o.c.

The cross-girders are I beams, the deck plate is supported by the cross-girders using small vertical supporting strips between the stringers and the cross-girders.

The following advantages are obtained:

1. Standardisation of the dimensions (length and width) of the deck sections composed of a steel plate and stringers. The standardisation is practically independent of the length and the width of the bridge.
2. Simplification of the shape of the cross-girders (I beams), through which the fabrication can be done economically, particularly when using the possibilities that modern welding techniques can offer.
3. The division in standardised elements has a favourable influence on the transportation of the units and the assembling of the bridge.

The general arrangement of a bridge built up with standardised elements and the sequence of assembling is given in figure 4.

With this type of construction, consideration must be given to the horizontal displacements between the deck plate and the top flange of the cross-girder that occur as a result of the live loads.

The cause fluctuating deformations in the trough-type stringers in the points A, B and C (fig.5), which arises the question what the influence is with regard to fatigue.

Furthermore the influence of the reaction of the cross-girders towards the stringers with regard to the buckling of the webs of the stringers

must be checked. To investigate these effects, tests have been carried out in which the boundary conditions were practically in accordance with those of the bridge-deck (6).

Tests with regards to the horizontal displacements.

The set-up of the tests were such that two connections as given in fig.5 could be tested simultaneously. The results of the tests are given in table 3.

Test specimen no.1 received first a relative displacement from 0.3 mm to 1.2 mm with a frequency of 6 Hz. After 2.080.000 cycles no damage was noticed. After that the displacement was increased from 0.3 mm to 1.7 mm with another 4.019.000 cycles.

For the recorded cracks see table 3. Test specimen no.2 received first a relative displacement from 0.3 mm to 1.2 mm after that from 0.3 mm to 1.7 mm and finally from 0.3 mm to 2.0 mm.

Test specimen no.3 received a relative displacement from 0.3 to 3.0mm. As can be seen from table 3 the number of cycles that has been obtained is very large. It has been noticed that the cracks grew very slowly and that at the end of the tests the cracks at point A, that occurred first, were not through and through. Also could be concluded that the

cracks did not have any influence on the carrying capacity of the steel deck.

The relative displacement between bridge-deck and cross-girders in a bridge construction as given in fig.4 are the following:

- a. Due to a normal rush hour traffic loading 0.5 mm;
- b. Due to a very dense and heavy traffic loading 1.5 mm.

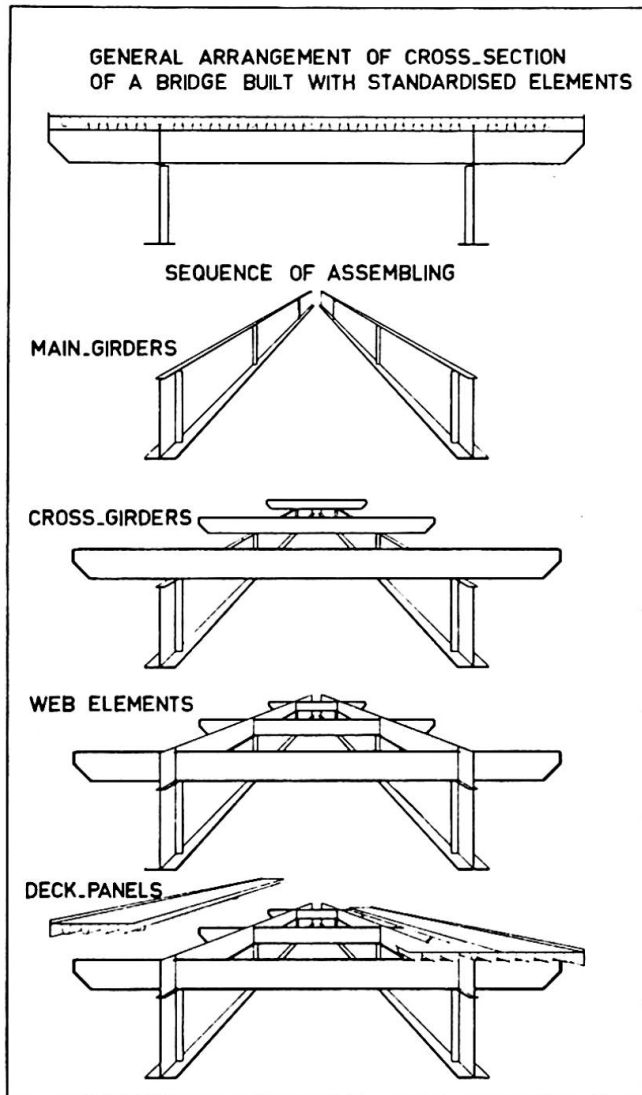

figure 4.

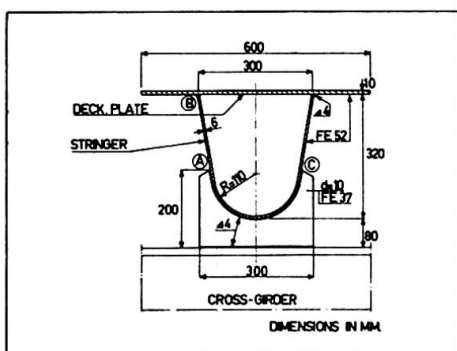

figure 5.

### Tests with regard to the bearing capacity.

The loads were applied symmetrical to the axis of the trough-type stringer as well as eccentric. Also an extreme horizontal displacement between deck and cross-girder of 3.0 mm has been taken into account.

From these tests it was found that the static ultimate strength was about 60 tons, whilst with a load of 30 tons plastic deformations developed. A small eccentricity of the load had no influence on the strength of the connection.

The maximum force in this bearing construction as a result of the loading conditions prescribed in the Dutch Standards is 16 tons, which means that the safety factor against failing is sufficient large.

Test-specimen	cycles		Recorded cracks
	amplitude mm	number	
1	0,3 - 1,2	0	none
		2.080.000	
		0,3 - 1,7	
	0,3 - 1,7	0	one box point A other box point A end of test, after that: weld B not through and through.
		445.000	
		1.760.000	
2	0,3 - 1,2	0	none
		2.017.000	
		0,3 - 1,7	
	0,3 - 1,7	0	one box point A, two cracks the same box, weld point B, through and through
		1.180.000	
		3.000.000	
	0,3 - 2,0	0	other box point A end of the test
		580.000	
		7.100.000	
3	0,3 - 3,0	0	one box point A other box point A first crack through and through second " " " " third crack point C end of test, after that: weld B, not through and through
		200.000	
		280.000	
		1.000.000	
		1.450.000	
		1.500.000	
2.040.000			

table 3.

Various bridges adopting the described system are under construction, for instance the bridges across the new Scheldt-Rhine canal at the Kreekrakdam.

Figure 6 gives some major information of one of the bridges at this location.

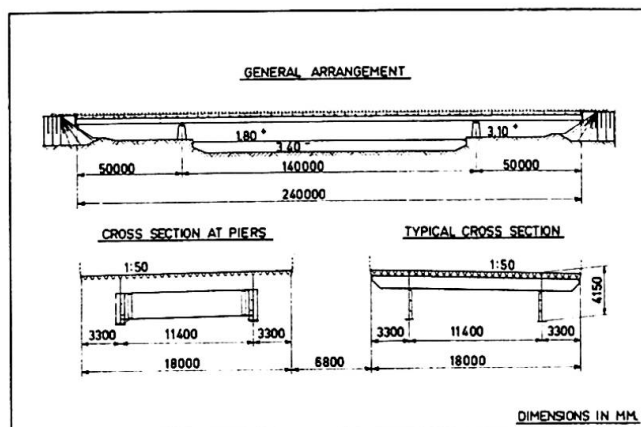

figure 6.

### Bibliography.

- (1) Neuartige Verbundmittel (Vorläufige Richtlinien) Österreichischer Stahlbauverband.
- (2) A.A.S.H.O. Design specification for Highway Bridges.
- (3) Composite construction in structural steel and concrete British Standard Code of Practice CP-117-I and II.
- (4) Onderzoek naar de afschuifsterkte van stiften voor samengestelde liggers, waarvan de gewapende betonplaat is uitgevoerd in lichtbeton. Rapport no.B-69-154/05.2.124 TNO-IBBC-Netherlands.
- (5) Fatigue strength of cover plated beams. Report 6-70-12 Stevin Laboratory Technical University Delft.
- (6) Onderzoek van de verbinding langsligger-dwarsdrager voor een ontworpen stalen brug over de IJssel bij Deventer. Rapport no.6-69-6 Stevin Laboratory Technical University Delft.

### Summary.

In this contribution a description is given of the application of a composite construction in light-weight concrete and the results of push out test of studs in light-weight concrete. Also the results of tests with regard to the connection of additional flange plates to beams by using high strength bolts in co-operation with fillet welds. In the end a description is given of a standardised system for bridges with a steel deck and the tests made for this system.