

Large plastic and viscous deformations of dynamically loaded structures

Autor(en): **Kaliszky, S.**

Objekttyp: **Article**

Zeitschrift: **IABSE congress report = Rapport du congrès AIPC = IVBH
Kongressbericht**

Band (Jahr): **9 (1972)**

PDF erstellt am: **21.07.2024**

Persistenter Link: <https://doi.org/10.5169/seals-9541>

Nutzungsbedingungen

Die ETH-Bibliothek ist Anbieterin der digitalisierten Zeitschriften. Sie besitzt keine Urheberrechte an den Inhalten der Zeitschriften. Die Rechte liegen in der Regel bei den Herausgebern.

Die auf der Plattform e-periodica veröffentlichten Dokumente stehen für nicht-kommerzielle Zwecke in Lehre und Forschung sowie für die private Nutzung frei zur Verfügung. Einzelne Dateien oder Ausdrucke aus diesem Angebot können zusammen mit diesen Nutzungsbedingungen und den korrekten Herkunftsbezeichnungen weitergegeben werden.

Das Veröffentlichen von Bildern in Print- und Online-Publikationen ist nur mit vorheriger Genehmigung der Rechteinhaber erlaubt. Die systematische Speicherung von Teilen des elektronischen Angebots auf anderen Servern bedarf ebenfalls des schriftlichen Einverständnisses der Rechteinhaber.

Haftungsausschluss

Alle Angaben erfolgen ohne Gewähr für Vollständigkeit oder Richtigkeit. Es wird keine Haftung übernommen für Schäden durch die Verwendung von Informationen aus diesem Online-Angebot oder durch das Fehlen von Informationen. Dies gilt auch für Inhalte Dritter, die über dieses Angebot zugänglich sind.

S. KALISZKY
 Sc.D., Professor of Civil Engineering
 Technical University
 Budapest, Hungary

Large Plastic and Viscous Deformations of Dynamically Loaded Structures

Les grandes déformations plastiques et visqueuses des structures sous charge dynamique

Grosse plastische und viskose Verformungen dynamisch belasteter Konstruktionen

1. INTRODUCTION

The general report points out very clearly that under statical conditions the plastic and viscous deformations and the effects of geometry changes influence significantly the ultimate behavior of structures. The purpose of this report is to illustrate, that these phenomena play even more important role in structures which are subjected to impulsive or pressure (blast-type) loading and undertake large deformations. At this special kind of loading the maximum deflections and the load carrying capacity depend on the energy which can be absorbed by the structure. In case of elasto-plastic material the plastic energy dissipation capacity is usually dominant and allowing moderately large plastic deformations the changes in geometry also influence its magnitude in a considerably manner. In addition, some materials (e.g. mild steel) are sensitive to strain-rate, therefore, considering rapid loading the viscous properties can have also an important effect.

The exact analysis of this kind of problems even at very simple structures results in fairly complicated calculations, which cannot be used widely in the practice (see e.g. [6,7]). In order to overcome these difficulties among others a simple approximate method has been elaborated for the estimation of the permanent deflections [4,5,8]. This method will form the basis of our forthcoming investigation.

2. THE CONCEPT OF THE APPROXIMATE METHOD

The state of a rigid-plastic structure with density ρ is characterized by the displacement, velocity and acceleration fields u_i , \dot{u}_i and \ddot{u}_i .

At pressure loading the external pressure can be described in the form $T_i = p(t)T_i^0$. Here T_i^0 is the function of coordinates x_i and defines the distribution of loading, while the load parameter $p(t)$ gives its magnitude in any instant of time. In our investigations

$$\begin{array}{ll} \text{if } 0 < t < t_0 & p(t) \equiv p_0 \\ \text{if } t > t_0 & p(t) \equiv 0. \end{array}$$

The initial conditions of motion are: at $t=0$, $u_i = \dot{u}_i = 0$.

At impulsive loading $p(t) \equiv 0$, but an initial velocity field V_i is prescribed: at $t=0$, $u_i = 0$, $\dot{u}_i = V_i$.

During the dynamic response the displacements of the structure change not only their magnitude but their distribution, as well (travelling hinges etc.). Consequently, they can be expressed in the general form $u_i(x_i, t)$. The aim of our approximate method is to replace the actual displacements by a stationary kinematically admissible displacement field u_i^* which can be expressed in a product form $u_i^* = W_0(t) u_i^c(x_i)$. Using this mode approximation the determination of the maximum permanent displacements is reduced to the solution of a one-degree-of-freedom system [8]. The differential equation of motion of this equivalent system is

$$W_0 = K[p(t) - r(t)] \quad (1)$$

where

$$K = \frac{\int_A T_i^0 u_i^c dA}{\int_V \rho u_i^c u_i^c dV} \quad (2)$$

and $r(t)$ is the resistance displayed by the structure under quasi-static conditions. This function can also be approximated in a product-form

$$r(t) = p_c r_1(W_0) r_2(\dot{W}_0) \quad (3)$$

where p_c is the simple collapse load factor and r_1 and r_2 express the influence of changes in geometry and strain-rate sensitivity, respectively. They all are related with the predicted displacement field u_i^c .

In most structures r_1 and r_2 can be expressed in the simple form:

$$r_1 = 1 + z_1 W_0^n, \quad r_2 = 1 + z_2 \dot{W}_0^m. \quad (4)$$

Here z_1 , z_2 , n and m are constants, $w_0 = W_0/H$ and H is a characteristic dimension (thickness) of the structure. Then, equation (1) can be transformed as bellow.

a/ Pressure loading:

$$\frac{d^2 w_0}{d\tau^2} + \frac{\lambda_0^2}{\eta^2} \left[1 + z_1 w_0^n \right] \left[1 + z_2 \left(\frac{dw_0}{d\tau} \right)^m \right] = \delta \frac{\lambda_0^2}{\eta} \quad (5)$$

Where $\tau = t/t_0$, $\lambda_0 = KI^2/Hp_c$, $I = p_0 t_0$, $\eta = p_0/p_c$

and

if $0 < \tau < 1$, $\delta = 1$,

if $\tau > 1$ $\delta = 0$.

b/ Impulsive loading:

$$\frac{d^2 w_0}{dt^2} + \frac{v_0^2}{\lambda_0} \left[1 + z_1 w_0^n \right] \left[1 + z_3 \left(\frac{1}{v_0} \frac{dw_0}{dt} \right)^m \right] = 0 \quad (6)$$

Here $z_3 = v_0^m z_2$ and $v_0 = V_0/H$. The latter denotes the parameter of the initial velocity field and can be determined from the impulse I , which represents the dynamic pressure.

The purpose of our investigation is to determine the maximum value of w_0 when the structure is in rest: i.e. at $t=t_f$, $\dot{w}_0=0$, and $w_0=w_0^{\max}$. Then, the maximum permanent displacements can be estimated:

$$u_i^{\max} \approx w_0^{\max} u_i^c$$

Using the present approximate method the investigation of different problems is relatively simple. The quasi-static solutions are available in the literature or can be gained by the suitable assumption of the functions (4). The non-linear second order differential equations (5) and (6), respectively, are to be solved numerically.

3. APPLICATIONS

In order to illustrate the application of the method and the influence of geometry changes and viscous effects on the dynamic response of structures some results of our investigations will be presented.

3.1 CIRCULAR PLATE

The simply supported circular rigid-viscoplastic plate with outer radius $r=R$ and fully plastic moment M_0 is subjected to a uniformly distributed dynamic pressure represented by an impulse per unit area (I). The transverse deflections and the initial velocities are assumed

$$w = w_0(t) \left(1 - \frac{r}{R} \right)$$

$$v = v_0 \left(1 - \frac{r}{R} \right)$$

Here $v_0 = V_0/H$ and from dynamical considerations $V_0 = 2 I/\mu$, $\mu = \rho H$. The simple collapse load factor is $p_c = 6M_0/R^2$ and according to equation (2) $K = 2/\mu$.

The effect of membrane forces at large deflections will be taken into account by choosing $z_1 = 1/3$ and $n=2$ in equation (6) [1]. The influence of strainrate sensitivity in steel plates can be also significant. In case of linear viscosity the parameters of equation (6) are $z_3 = 0,8(HV_0/\gamma R^2)$, $m'=1$. Here the viscous constant γ can be determined from experiments [3]. In case of non-linear viscosity $z_3'' = 1,13(HV_0/2DR^2)^{1/m''}$, where for steel $m''=1/5$ and $D=40,4 \text{ sec}^{-1}$ [6].

Some results of our investigations are plotted in Fig.1.

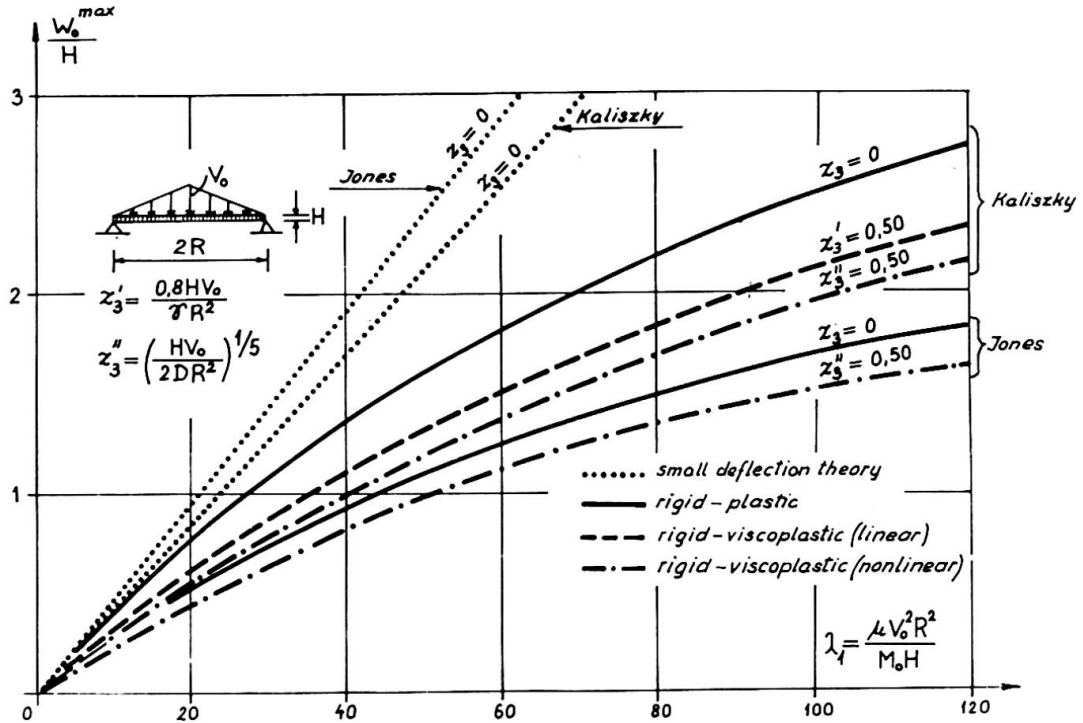

Fig.1. Circular plate under impulsive loading.

Here, for the sake of comparison, N. Jones' more accurate solution and the results of the simple bending theory are also illustrated [6,7]. Fig.2. represents the maximum permanent deflections in case when the structure is subjected to a pressure loading and the viscous effects are not taken into consideration.

3.2 SHALLOW SPHERICAL SHELL

Consider a rigid-plastic shallow spherical membrane shell with a hinged edge and subjected to an internal dynamic pressure uniformly distributed over the plane (Fig.3.). According to the membrane solution the simple collapse load factor is $p_c = 2N_0/R$, $N_0 = \sigma_0 H$ and assuming the transverse deflections in the form

$$w = w_0(t) \left[1 - \left(\frac{r}{L} \right)^2 \right]$$

the constant defined by equation (2) is $K = 3/2\mu$. As the quasi-static solution of problem shows [9] taking into consideration the influence of changes in geometry the parameters in equation (5) can be chosen as $n=1$,

$$z_1 = \left(\frac{R}{H} \right) \left(\frac{L}{R} \right)^2 \quad \text{and omitting the viscous effects} \quad z_2 = 0.$$

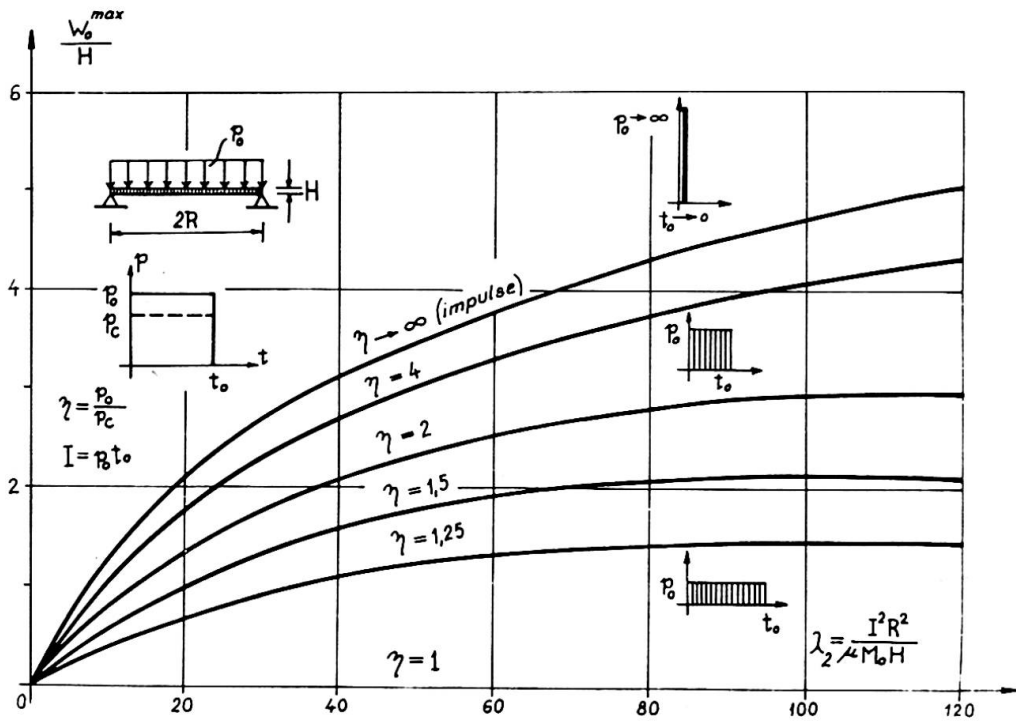

Fig.2. Circular plate under pressure loading.

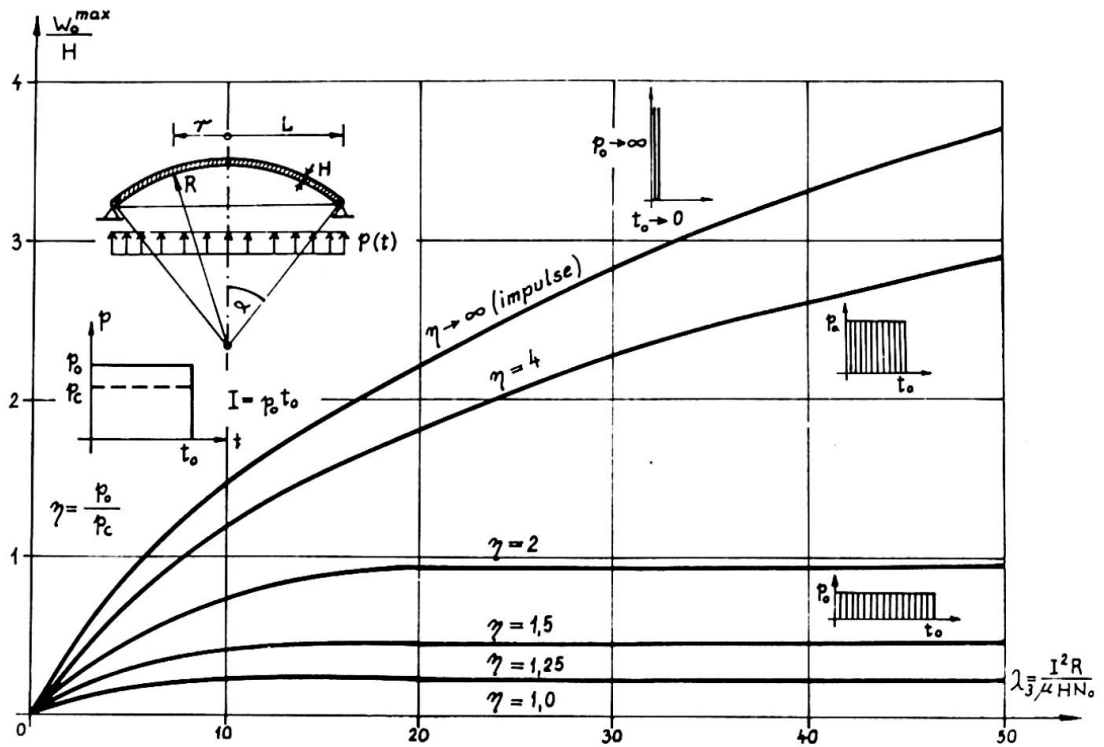

Fig.3. Spherical shell under pressure loading.

To illustrate the results the maximum permanent deflections in the function of $\eta = p_0/p_c$ and $\lambda_3 = I^2 R/\mu H N_0$ for the parameters $R/H=25$ and $L/R=\sin\alpha = 0,20$ are given in Fig.3.

3.3 PORTAL FRAME

Consider an encastred rigid-plastic portal frame with constant fully plastic moment M_0 subjected to constant vertical loads V and to uniformly distributed horizontal dynamic pressure $p(t)$ (Fig.4.). Assuming plastic hinges at the top and the bottom of the columns the simple collapse load factor and the constant defined by equation (2) can be obtained $p_c = 8M_0/L^2$ and $K=3/5\mu_0$. Here μ_0 is the mass per unit length.

In our former examples the changes in geometry were increasing the resistance of the structure. At the present problem, however, during the horizontal displacements the increasing moments caused by the vertical loads are decreasing the resistance of the frame. Taking into account this effect the parameters of equation (5) can be determined from simple statical considerations: $z_1 = -(V/p_c)L(H/L)$, $n=1$ and omitting the viscous effects $z_2=0$.

Using the parameters $H/L=1/10$ and $V/P_c L=5$ the maximum horizontal displacements in the function of $\lambda_4 = I^2 L^2/\mu_0 H M_0$ are illustrated in Fig.4. Here H denotes the constant height of the cross-sections.

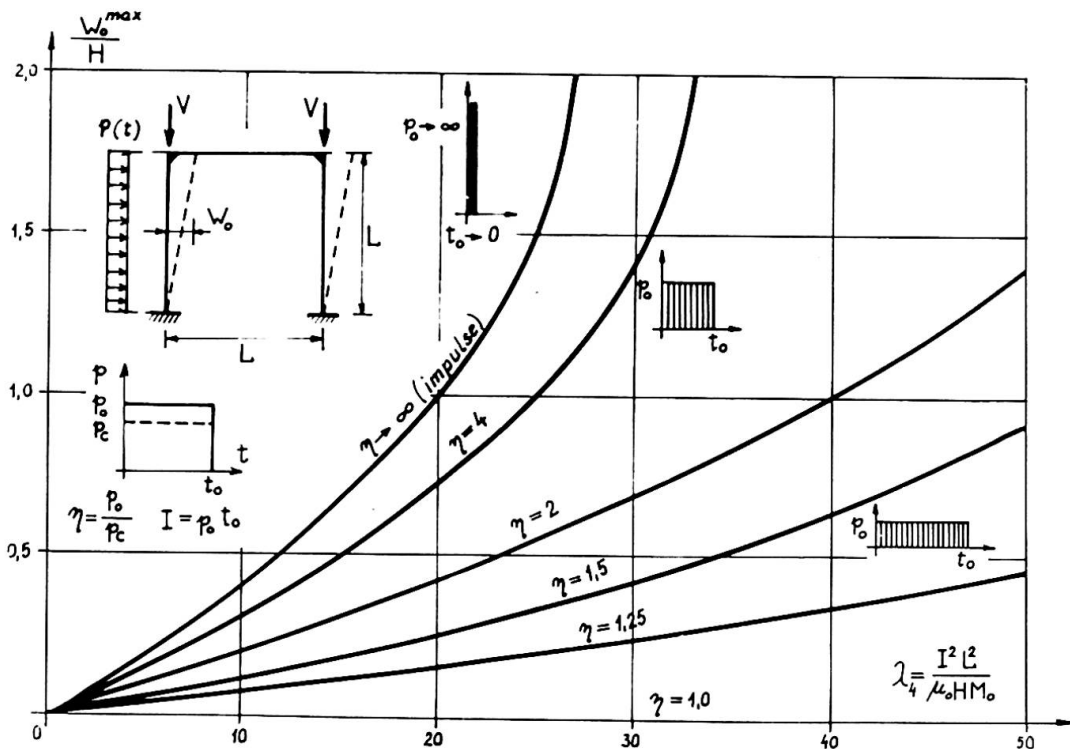

Fig.4. Portal frame under pressure loading.

4. CONCLUSIONS

According to our investigations the changes in geometry can influence the maximum permanent deflection of structures significantly. In particular this effect is very important when as a consequence of compressive forces the resistance of the structure is of decreasing character. Then, the neglect of the second order effects is at the safety's cost. The strain-rate sensitivity even in steel structures does not have a great importance.

Whenever the load-deflection and deflection-rate relation of the corresponding static problem is known or can be described approximately, the method presented can be used for the rapid calculation of the maximum permanent deflections of any kind of structures subjected to pressure or impulsive loading. The idea of the method can be extended for the investigation of other piecewise linear or non-linear phenomena as e.g. strain-hardening and elasto-plastic deformations.

REFERENCES

- 1 T.Wierzbicki, Bounds on large dynamic deformations of Structures, Journal of Engineering Mechanics Division, ASCE, Vol.96, No.EM3, Proc.Paper 7344, June, 1970. /257-276/
- 2 B.J.Martin and P.S.Symonds, Mode approximations for impulsively-loaded rigid-plastic structures. J.Engng.Mech.Div.ASCE 92.EM5. 43. /1966/.
- 3 T.Wierzbicki, A Method of approximate solution of boundary value problems for rigid-viscoplastic structures. Acta Mechanica Vol. III/1, 1967.
- 4 S.Kaliszky, Approximate solutions for impulsively-loaded inelastic structures and continua. Int.J.Non-Linear Mechanics, Vol. 5, /143-158/ /1970/.
- 5 S.Kaliszky, Approximate solutions for impulsively-loaded rigid-plastic structures and continua. Bull.Acad.Polonaise, Vol.XVII. No.5. /1969/.
- 6 N.Jones, Finite deflections of a rigid-viscoplastic strain-hardening annular plate loaded impulsively. Journal of Applied Mechanics Vol.35, No.2, /349-356/ 1968.
- 7 N.Jones, A theoretical study of the dynamic plastic behavior of beams and plates with finite-deflections. Int.J.Solids Structures. Vol.7. 1971. /1007-1029/.
- 8 S.Kaliszky, Large deformations of rigid-viscoplastic structures under impulsive and pressure loading. Journ.of Structural Mechanics /in press/.
- 9 M.Duszek, Plastic analysis of shallow spherical shells at moderately large deflections. IUTAM Symposium, Copenhagen, 1967.

SUMMARY

An approximate method is presented for the prediction of the maximum permanent deflections of structures undertaking large plastic and visco-plastic deformations under impulsive or pressure loading. As illustrative examples a circular plate, a shallow spherical shell and a portal frame are investigated. According to the numerical results mainly the effect of changes in geometry can influence the response of dynamically loaded structures significantly.