

**Zeitschrift:** IABSE congress report = Rapport du congrès AIPC = IVBH  
Kongressbericht

**Band:** 10 (1976)

**Artikel:** Industrialized apartment buildings composed of steel frame and precast  
concrete panels

**Autor:** Hisada, Toshihiko / Sasaki, Tetsuya

**DOI:** <https://doi.org/10.5169/seals-10484>

### **Nutzungsbedingungen**

Die ETH-Bibliothek ist die Anbieterin der digitalisierten Zeitschriften. Sie besitzt keine Urheberrechte an den Zeitschriften und ist nicht verantwortlich für deren Inhalte. Die Rechte liegen in der Regel bei den Herausgebern beziehungsweise den externen Rechteinhabern. [Siehe Rechtliche Hinweise.](#)

### **Conditions d'utilisation**

L'ETH Library est le fournisseur des revues numérisées. Elle ne détient aucun droit d'auteur sur les revues et n'est pas responsable de leur contenu. En règle générale, les droits sont détenus par les éditeurs ou les détenteurs de droits externes. [Voir Informations légales.](#)

### **Terms of use**

The ETH Library is the provider of the digitised journals. It does not own any copyrights to the journals and is not responsible for their content. The rights usually lie with the publishers or the external rights holders. [See Legal notice.](#)

**Download PDF:** 02.02.2025

**ETH-Bibliothek Zürich, E-Periodica, <https://www.e-periodica.ch>**

**Industrialized Apartment Buildings Composed of Steel Frame and Precast Concrete Panels**

Construction industrialisée d'appartements avec une ossature métallique et des panneaux préfabriqués en béton

Industriell hergestellte Wohnbauten, bestehend aus Stahlskelett und vofabrizierten Deckenplatten

**TOSHIHIKO HISADA**

Dr. Eng. Director

**TETSUYA SASAKI**

Senior Research Engineer

Kajima Institute of Construction Technology, Kajima Corporation  
Tokyo, Japan

1 PREFACE

In recent years in Japan, the convergence of the population into cities and their surrounding districts is remarkable. This has created the need for effective use of urban area and for increase in the number of housings. Consequently the development of the industrialized system for construction of tall apartment buildings are gaining demand. The research on the structural system of these buildings was carried out mainly from the aseismic point of view, because Japan is one of the worst earthquake countries in the world. Thus, the structural system composed of combined steel frame and precast concrete panels was newly developed, and group of apartment buildings 7 stories high, were constructed for the first time by this system in 1966. Thereafter this system and its variations have played the main roles for the construction of tall apartment buildings using industrialized process. Currently, the tallest example is 21 stories high (See Fig. 7), and the total number of dwellings constructed by these systems is roughly estimated to be about fifty thousand.

This paper deals with the structural characteristics of the apartment buildings constructed by said system on the basis of seismic tests and analyses, and also reference is made to some of the structural problems particular to these buildings.

2 STRUCTURAL SYSTEM

Fig. 1 shows the outline of the structural system of a 14 story apartment building on which structural researches were performed. In this building, lateral forces are resisted respectively by frame structures mainly composed of structural steel frame in longitudinal direction and by seismic shear walls in transversal direction. The strong axis of the H shaped steel columns are arranged in longitudinal direction of the building so as to resist the lateral force effectively.

In course of the construction, steel columns prefabricated to 3 stories length are erected. Next, steel beams encased in concrete with or without curtain walls and precast concrete shear walls embracing steel tie beams or tie plates at the top are jointed to the steel columns respectively in longitudinal

and transversal directions, and then precast concrete floor slabs are laid on the beams and walls. After reinforcing and forming of the columns, concrete is then placed.

Steel beams are connected to steel columns by welding and bolting as shown in Fig. 2. Precast shear walls are jointed by bolting, welding and shear connectors. Precast shear walls with steel braces and concrete floor slabs poured at the site are applied in some cases.

A revised system was developed recently in which considerable portion of the seismic forces in longitudinal direction of the building is resisted by reinforced concrete, and consequently several tall apartment buildings were constructed by this system which was successful in saving considerable construction costs. (See Fig. 3)

### 3 METHOD OF ASEISMIC DESIGN

Seismic forces prescribed by the Japanese Building code were used for the aseismic design of these buildings. Structural members were determined by the Structural Standard of Architectural Institute of Japan. In longitudinal direction of the building, the structural design of steel frame was made to resist the bending and shear, while reinforced concrete of the columns was designed to carry the axial forces. In transversal direction of the building shear walls were designed to resist the seismic force and the columns on both sides of the walls were designed to resist the over-turning of the building. As for the new type joints, load tests on joint specimens were performed and the allowable strength of the joints were properly determined from test results.

Because the structural system was a new development, load tests of the structural specimens including main connectors and joints were carried out to confirm the structural characteristics of the building, and the test results were fed back into the structural design. Observation of the dynamic behavior of the building was made by forced vibration tests. Finally, the aseismic safety of the building was confirmed through earthquake response analyses based on the test results.

### 4 STRUCTURAL TESTS

Static load tests of the structural specimens were performed to investigate the aseismic characteristics of the building shown in Fig. 1.

#### (1) Structural characteristics of the shear wall structure

A shear wall specimen of reduced 1/2 scale was prepared for the load test. The specimen represented two stories of the shear wall structure in transversal direction of the building. The shear wall of one story was composed of two precast concrete panels and a steel tie beam was provided at each floor level. The joints of the panels were formed with a combination of shear keys of concrete and stud dowels. The specimen was fixed to the testing floor at the bottom of the columns, and repeated lateral forces were applied alternately to the specimen at each floor level.

Fig. 4 shows the relation between the average shear stress and the shear deformation of the lower wall. The maximum strength of the specimen was 3.8 times as large as the design load and the joints possessed adequate strength and stiffness throughout the test. The deformation of the specimen at the maximum shear stress was about  $4 \times 10^{-3}$  rad..

#### (2) Structural characteristics of the frame structure

The load tests on the specimen of reduced 1/2 scale, which represented a two span-two stories unit frame with curtain walls, were performed to investigate the structural characteristics of the structure in longitudinal direction

of the building. The repeated lateral forces were applied alternately to the ends of the columns of the specimen which was supported at the ends of the beams. Fig. 5 shows the load-deflection curve of the specimen. From this figure the following remarks can be obtained:

- a. The curve showed stable and ductile characteristics which were caused by the yielding in bending at the ends of steel beams. The residual displacements of the specimen caused by 1.5 times design load or less were very small.
- b. The maximum strength of the specimen was 2 times or more of the design load and its stiffness was considerably large.
- c. The stiffness of the specimen as calculated on the assumption that wing walls and column behave as one body coincided fairly well with the observed one.

## 5 VIBRATION TESTS AND ANALYSIS

The building shown in Fig. 1 is supported on drilled steel piles at average depth of about 25 meters below ground level in the relatively soft layers of clay and sand. The bearing capacity of the soil and the length of the piles beneath the basement vary considerably according to location.

The dynamic properties of the building were investigated by forced vibration tests using a vibrator. The test results are shown at the top of Table 1 and in Fig. 6. It is observed from Fig. 6 that transversal vibration characterized by the deformation of the shear walls and floor slabs in their planes was created. In the fundamental translational vibration in transversal direction of the building, the ratio of displacement at the top of the building caused by the swaying and rocking motion was 66%. In contrast with this, the vibration of the structure in longitudinal direction was of typical shearing type.

Considering the dynamic characteristics observed from the vibration tests, dynamic analysis in transversal direction of the building was performed of a two dimensional structural model characterized by the correlated stiffness matrix of shear wall and floor slab in their planes and supported on the base with the conditions obtained from the tests. The analyses were in good correlation to the observed results as shown in Fig. 6.

The vibration test results of buildings of the same type structure are also summarized in Table 1. The following remarks may be derived from these test results:

- a. The displacement due to rocking and swaying motions of the building was predominant in transversal displacement at the top of the building, especially in buildings supported by long piles driven in the soft layers of soil. In these cases the proportion of above mentioned displacement in total reached about 70 percent in maximum.
- b. Fundamental natural periods of buildings 30 meters high were distributed in the range of 0.5 to 0.65 sec. in transversal direction, and 0.3 to 0.75 sec. in longitudinal direction respectively. The wide range variation of the latter periods may be attributed to the variety of types of the curtain walls fixed to the structural frames.
- c. It should be noted that the period of torsional vibration (fundamental vibration of floor slabs) of slender buildings are close to the fundamental period of translational vibration of shear walls (fundamental translational vibration) and that the period of the vibration of the floor slabs in their planes (secondary vibration of floor slabs) was over 0.2 sec..
- d. As for the relationship between natural periods and damping factors, it was observed that the damping becomes larger with the decrease of the period.

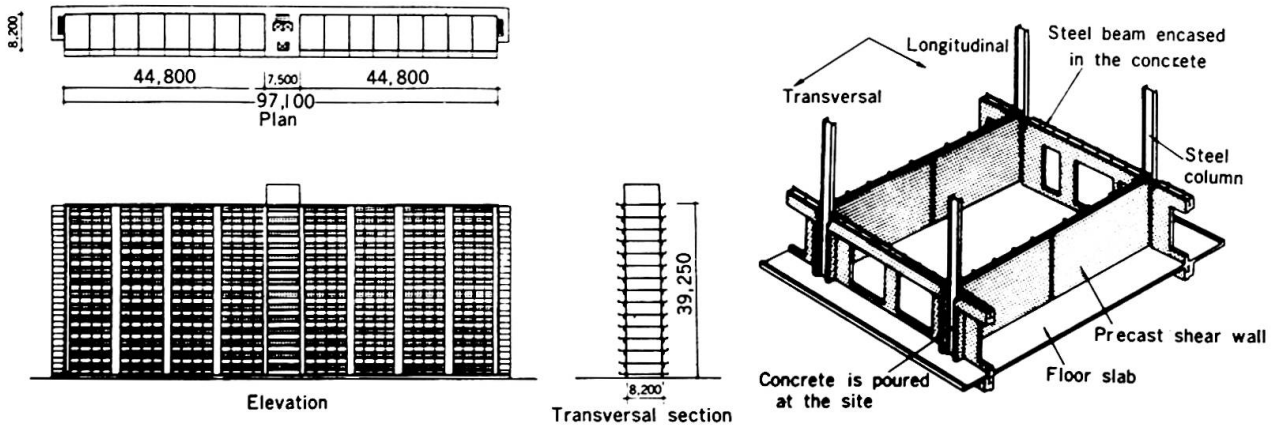

Fig. 1 Outline of a 14 story apartment building and its basic structural system

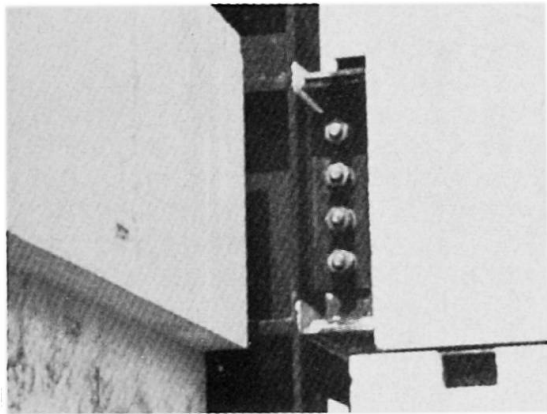

Fig. 2 Beam-column connection

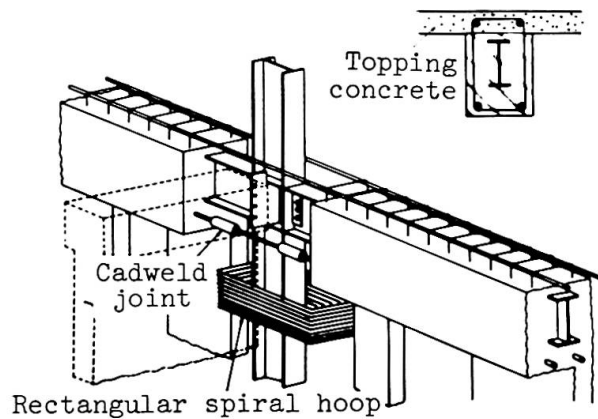

Fig. 3 Revised structural system

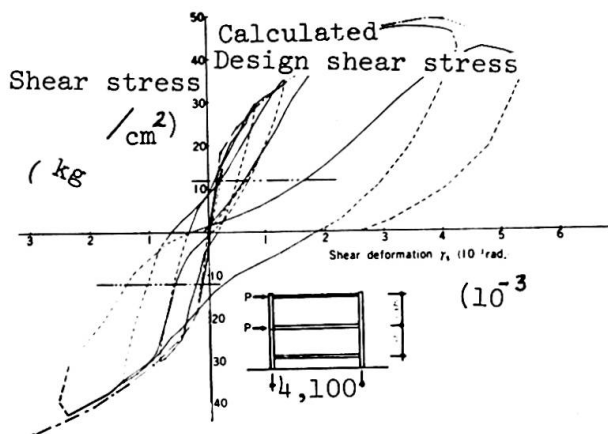

Fig. 4 Shear stress-shear deformation curve of shear wall specimen

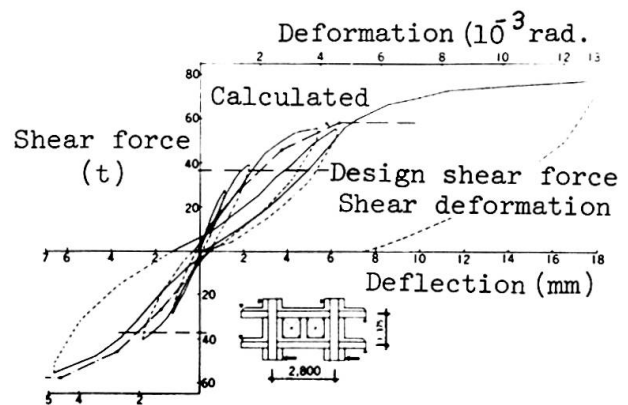

Fig. 5 Load-deflection curve of frame specimen

Table 1 Vibration test results

Bulg.	Dimension of building				Period s & damping factor (%)						Supporting	Proportion of sway & rocking
	Width (m)	Height		Length (m)	Transversal				Longitudinal			
		(m)	(Story)		Translational 1st	Translational 2nd	Floor slab 1st	Floor slab 2nd	1st	2nd		
(a)	8.2	38.5	14	102.8	0.66 2.0	—	0.55 1.7	0.28 1.4	0.46 3.0	0.15 12.0	25m Steel pile	66%
(b)	8.5	29.6	11	92.7	0.48 2.0	—	0.43 1.7	0.25 2.5	0.31 3.7	0.11 —	17m Steel pile	50% or more
(c)	7.8	30.1	11	78.0	0.59 2.4	0.075 7.1	0.51 2.9	0.22 4.5	0.44 4.4	0.073 3.6	30m Steel pile	70%
(d)	10.74	30.5	11	59.4	0.54 2.2	0.095 4.8	0.54 2.2	0.22 3.9	0.74 2.2	0.21 8.4	Loam	50%
(e)	17.88	61.6	21	52.0	0.85 1.4	0.20 5.7	0.69 1.3	0.11 6.5	0.66 1.6	0.22 5.5	11m Concrete pile	25%
(f)	20.0	29.7	11	129.6	0.62 3.0	—	0.59 2.5	0.41 3.5	0.47 —	0.133 3.5	40m Steel pile	68%
(g)	7.79	29.7	11	80.4	0.59 1.9	—	0.54 1.7	0.21 2.9	0.76 1.2	0.28 2.5	25m Steel pile	67%

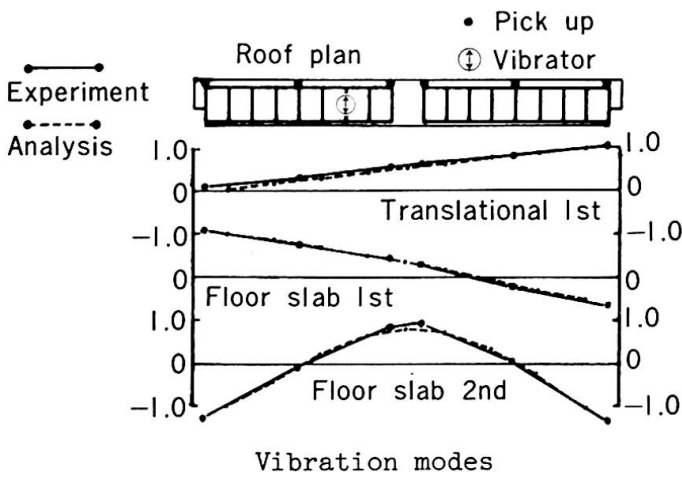

Fig. 6 Results of experiments and analyses on the vibration of the building in transversal direction



Fig. 7 A tall apartment building constructed by the industrialized system

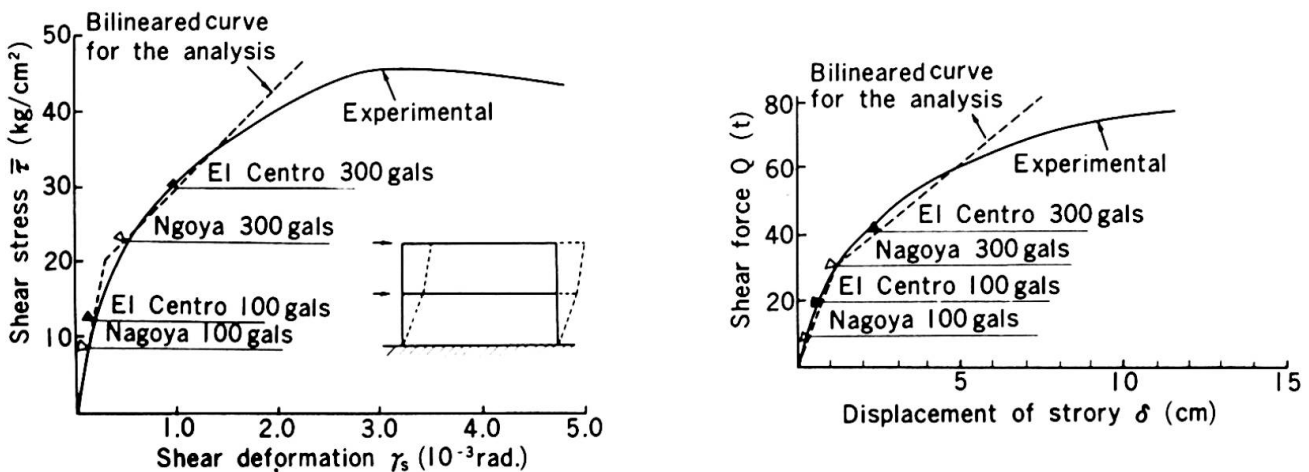

Fig. 8 Results of earthquake response analyses

## 6 EARTHQUAKE RESPONSE ANALYSIS

The earthquake response analyses of the building shown in Fig. 1 were made to confirm its aseismic safety. In transversal direction, a unit (1 span) of the building was treated as a flexural and shearing vibration model consisting of 14 lumped masses with rocking and swaying motion at the base. In this model, its flexure was assumed to be elastic and its shear to be bilinear. These properties were determined from the test result of the shear wall specimen. In longitudinal direction, the same unit was treated as a shearing vibration model fixed at the base. Bilinear characteristics of the model in shear were determined from the test results of frame specimens. In the analyses 5 % dumping factor was used, and El Centro and Nagoya earthquake accelerograms with modified maximum intensity of 100 gals and 300 gals each were applied to the models as the input earthquake motions.

The results of analyses are shown in Fig. 8, in which the maximum response shear forces are marked on the load-deflection curves used in the analyses. It is considered that the superstructure of the building has sufficient earthquake resistance in both longitudinal and transversal directions.

## 7 CONCLUSIONS

From the tests and analyses mentioned herein, the tall apartment buildings constructed by the systems composed of steel frame and precast concrete panels are considered to have adequate aseismic safety. In other words, these buildings are considered safe from destructive damage which might result in loss of human lives during severest earthquakes, provided that the joints of the prefabricated structural members are normally constructed.

It is desired that further investigations will be performed on the seismic analysis method for the total structure which consists of superstructure, foundations, soils and piles, and that the data for more reasonable evaluation of aseismic safety of such buildings will be accumulated.

The authors wish to thank Dr. K. Muto for his leadership on this research and development and Messrs. T. Tsugawa, S. Bessho and K. Ishii, Research Engineers of the Kajima Institute of Construction Technology, for their collaboration in the tests and analysis reported herein.

## SUMMARY

An industrialized structural system for tall apartment buildings which consists of steel frame and precast concrete panels was developed in Japan in 1966. Thereafter, many apartment buildings have been constructed by this system and its variations. This paper deals with load tests of structural specimens, earthquake response analyses and vibration tests of the apartment buildings constructed by this system and also refers to some structural problems which are particular to these buildings.

## RESUME

Un système de construction pour les habitations de grande hauteur a été développé au Japon en 1966, à partir d'une ossature métallique et de panneaux en béton préfabriqués. De nombreux bâtiments ont été réalisés avec ce système et ses variantes. Des essais de charge sur spécimens, une analyse du comportement sismique, et des mesures de vibration ont été réalisés sur des bâtiments de ce type. Quelques problèmes particuliers propres au système sont ensuite exposés.

## ZUSAMMENFASSUNG

Ein Baukastensystem für Wohnhochhäuser, bestehend aus Stahlrahmen und vorfabrizierten Deckenplatten wurde 1966 in Japan entwickelt. Seither wurden viele Bauwerke nach diesem Verfahren erstellt. Hier wird über verschiedene Versuche an Bauelementen, über das Tragverhalten bei Erdbeben, über das Schwingungsverhalten sowie über weitere, für das Bausystem typische Probleme berichtet.