

Full-scale failure tests with steel frames

Autor(en): **Halasz, Otto / Ivanyi, Miklos / Tomka, Pal**

Objekttyp: **Article**

Zeitschrift: **IABSE congress report = Rapport du congrès AIPC = IVBH
Kongressbericht**

Band (Jahr): **11 (1980)**

PDF erstellt am: **21.07.2024**

Persistenter Link: <https://doi.org/10.5169/seals-11374>

Nutzungsbedingungen

Die ETH-Bibliothek ist Anbieterin der digitalisierten Zeitschriften. Sie besitzt keine Urheberrechte an den Inhalten der Zeitschriften. Die Rechte liegen in der Regel bei den Herausgebern.

Die auf der Plattform e-periodica veröffentlichten Dokumente stehen für nicht-kommerzielle Zwecke in Lehre und Forschung sowie für die private Nutzung frei zur Verfügung. Einzelne Dateien oder Ausdrucke aus diesem Angebot können zusammen mit diesen Nutzungsbedingungen und den korrekten Herkunftsbezeichnungen weitergegeben werden.

Das Veröffentlichen von Bildern in Print- und Online-Publikationen ist nur mit vorheriger Genehmigung der Rechteinhaber erlaubt. Die systematische Speicherung von Teilen des elektronischen Angebots auf anderen Servern bedarf ebenfalls des schriftlichen Einverständnisses der Rechteinhaber.

Haftungsausschluss

Alle Angaben erfolgen ohne Gewähr für Vollständigkeit oder Richtigkeit. Es wird keine Haftung übernommen für Schäden durch die Verwendung von Informationen aus diesem Online-Angebot oder durch das Fehlen von Informationen. Dies gilt auch für Inhalte Dritter, die über dieses Angebot zugänglich sind.

**IX****Full-Scale Failure Tests with Steel Frames**

Essais à la ruine de portiques en acier, en vraie grandeur

Bruchversuche an Stahlrahmen im Originalmassstab

OTTO HALÁSZ

Prof. Dr. Sc.

Technical University Budapest
Budapest, Hungary

MIKLÓS IVÁNYI

Associate Prof. C. Sc.

Technical University Budapest
Budapest, Hungary

PÁL TOMKA

Senior assistant

Technical University Budapest
Budapest, Hungary

SUMMARY

Within a development program of mass-produced simple industrial steel structures a series of full-scale failure tests has been carried out. Effects of change in geometry, local instability and initial imperfections were analyzed, pointing out their importance in case of variable repeated loads.

RESUME

Au cours d'un programme de développement de constructions industrielles en acier, simples produites en série, on a fait des essais à la ruine en vraie grandeur. On a examiné les effets du changement de forme de la structure, du voilement local et des imperfections initiales, en soulignant leur importance en cas de charges variables répétées.

ZUSAMMENFASSUNG

Im Verlaufe eines Entwicklungsprogramms für Serienfertigung einfacher industrieller Stahlbauten wurden Bruchversuche im Originalmassstab durchgeführt. Einflüsse von Biegemomenten zweiter Ordnung, Plattenbeulung, Kippen und Anfangsimperfektionen wurden analysiert und ihre wesentliche Rolle im Falle wechselnd-wiederholter Belastung hervorgehoben.



1. INTRODUCTION

Connected to the mass-production of steel frames built up of welded cross-sections, full-scale failure tests seemed to be necessary to check the validity of some design rules based on the ample experimental data gained mainly by tests with rolled sections - as welded components allow a bigger variability of thickness-to-depth ratio of their plate elements, opening so a broader way for optimum design by using more slender components and increasing simultaneously the possible diminishing effect of instability phenomena on the load carrying capacity as predicted by a simple limit analysis.

The full-scale failure tests were carried out in the laboratory of the Department for Steel Structures of the Technical University Budapest aiming at a better insight into the effects of the

- /i/ change in geometry
- /ii/ spacing and efficiency of different types of lateral supports,
- /iii/ variable-repeated loading process, including light crane-loads with a limited number of load cycles,
- /iv/ limits of thickness-to-depth ratio of plate elements, and
- /v/ initial imperfections.

2. TEST PROGRAM

Fig. 1 gives a brief summary of the full-scale tests and the dimensions of the specimens, indicating the loads and the characteristics of the loading process. /Additional tests on stub columns, frame corners, plate elements are not mentioned./

The photo reproduced by Fig. 2 gives a general view of the test setup, the loading and load-distributing system. In Fig. 3 some instructive details - as plastic hinge formation terminated eventually by plate buckling, are demonstrated.

3. CONCLUSIONS

Space-limits not allowing a general discussion of the results - alluding to different publications [1] [2] [3]. Some of the conclusions judged to be of interest are summarized as follows:

/i/ The importance of adequate spacing of lateral supports and their efficiency in preventing the rotation of cross-section around the bar-axis has to be emphasized as purlins and rails connected to tension flanges often cannot be regarded fully effective in case of thin webs. Not only the load carrying can thus be substantially reduced /as by elastic lateral buckling in case of frame C-3/1 in Fig. 4/, but the yield plateau in the load-deflection diagram can be too short /as in the case of frame C-1 in Fig. 4/, rendering the structure sensitive against initial imperfections.

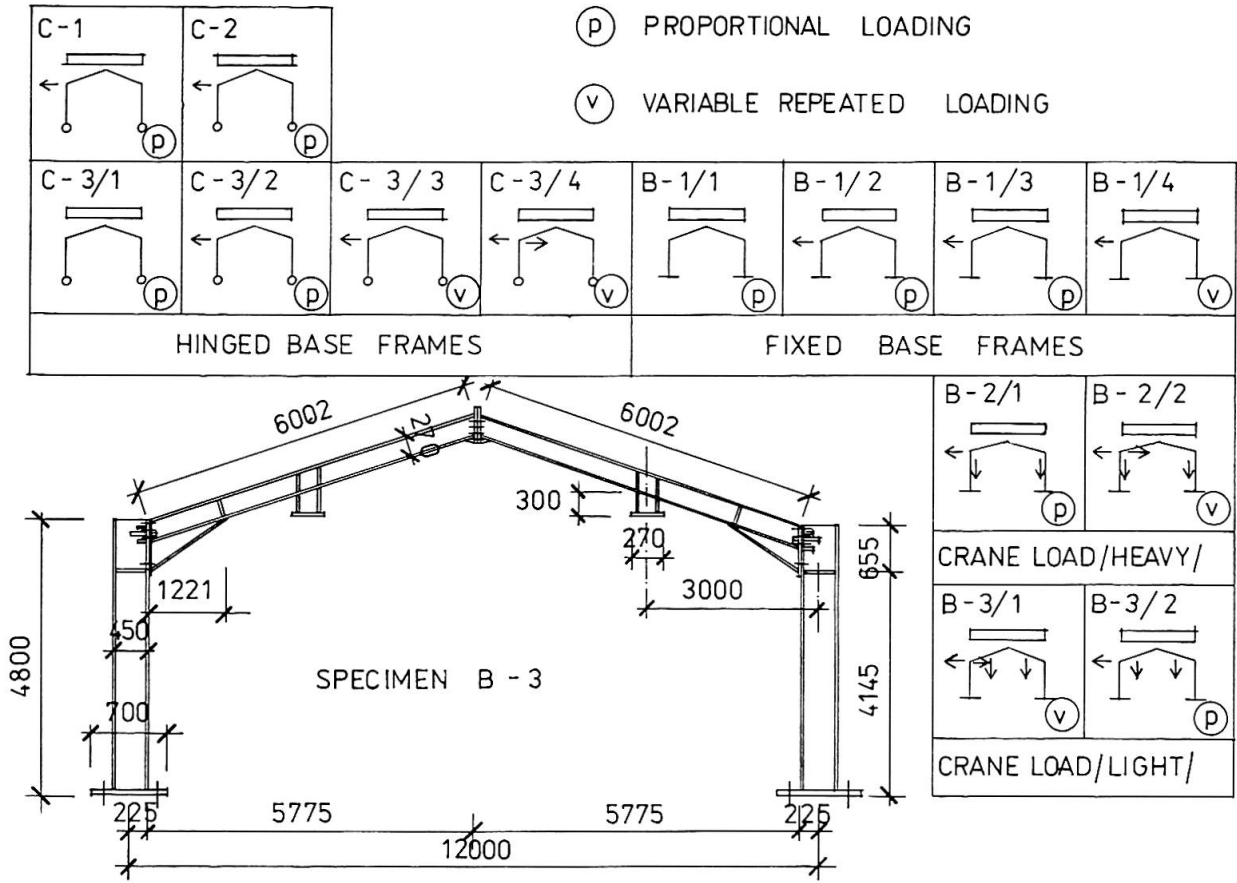

Fig.1.

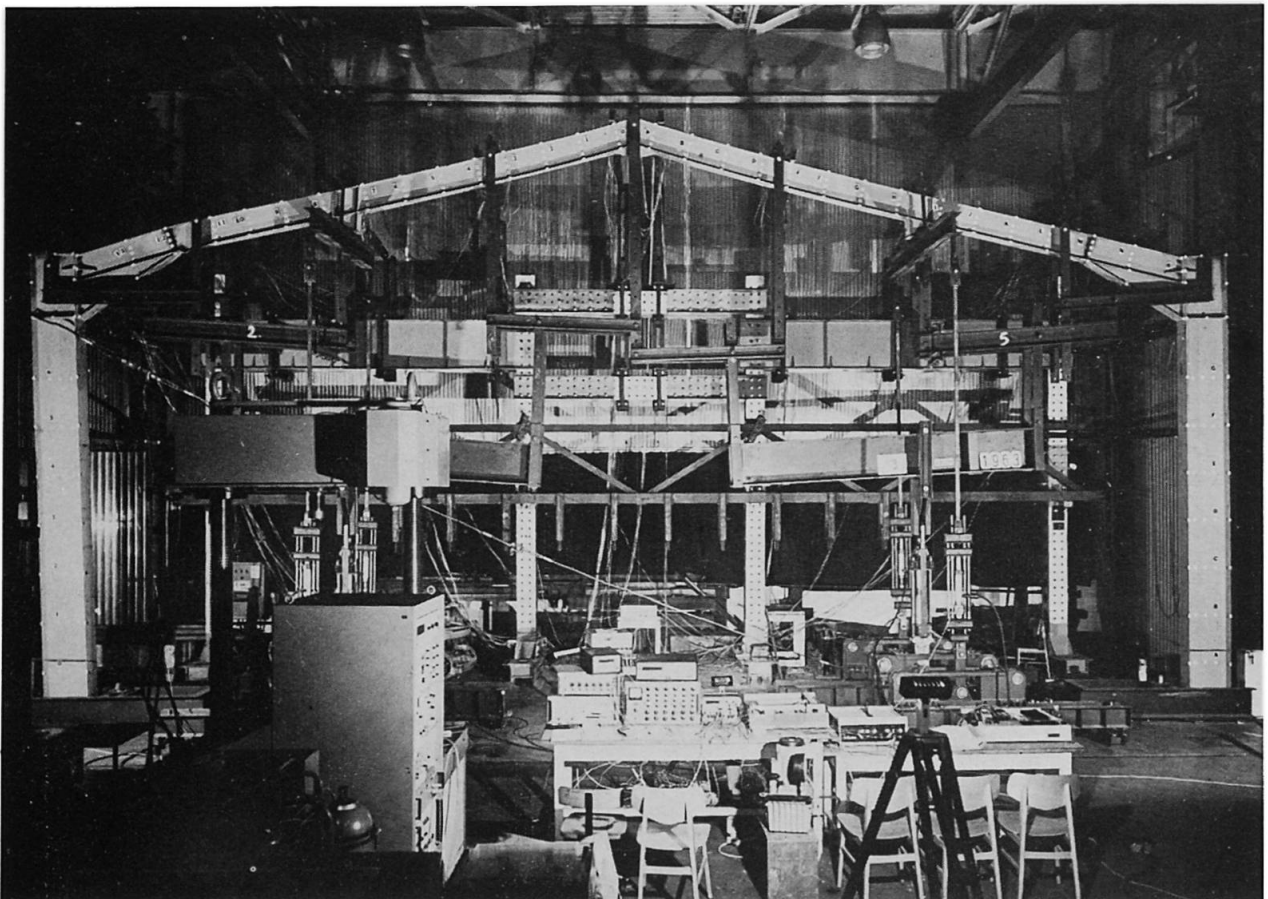

Fig. 2.

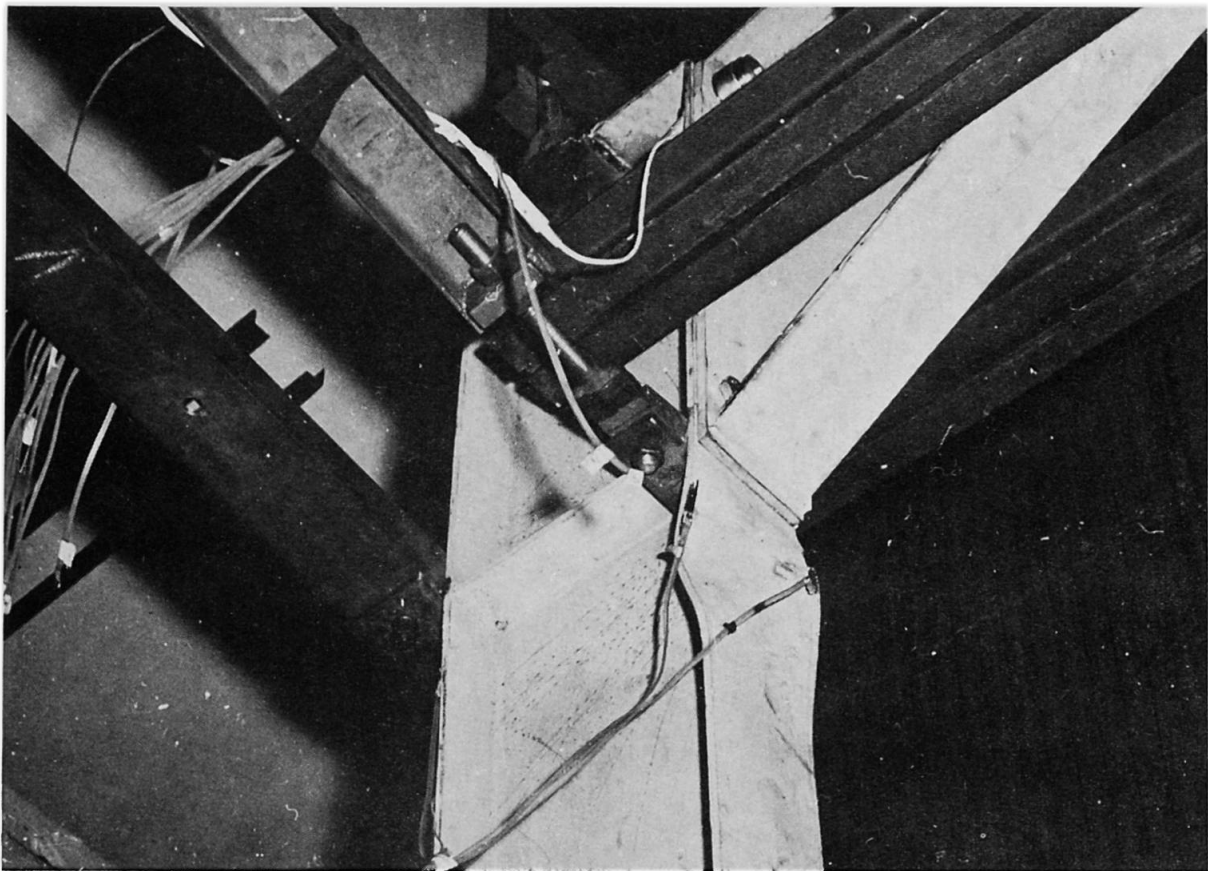
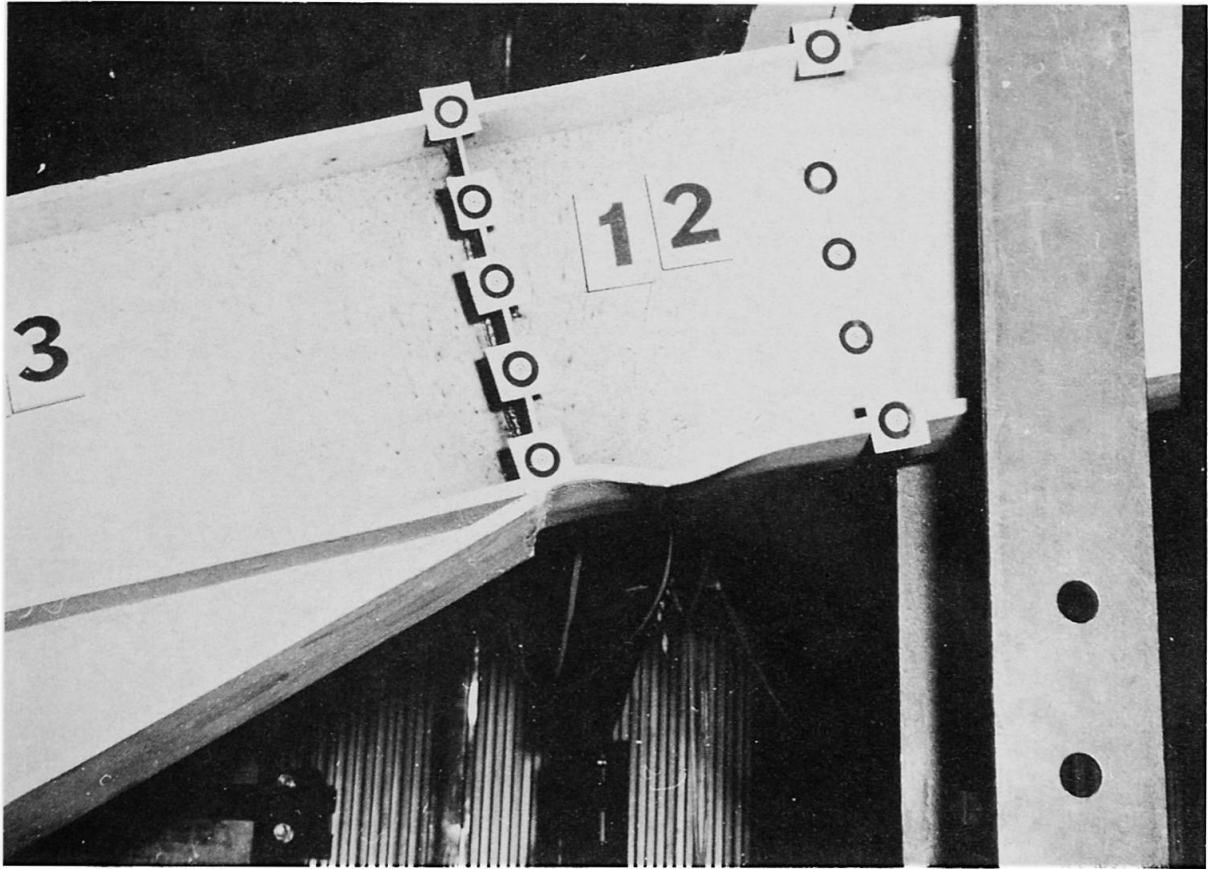

Fig. 3.

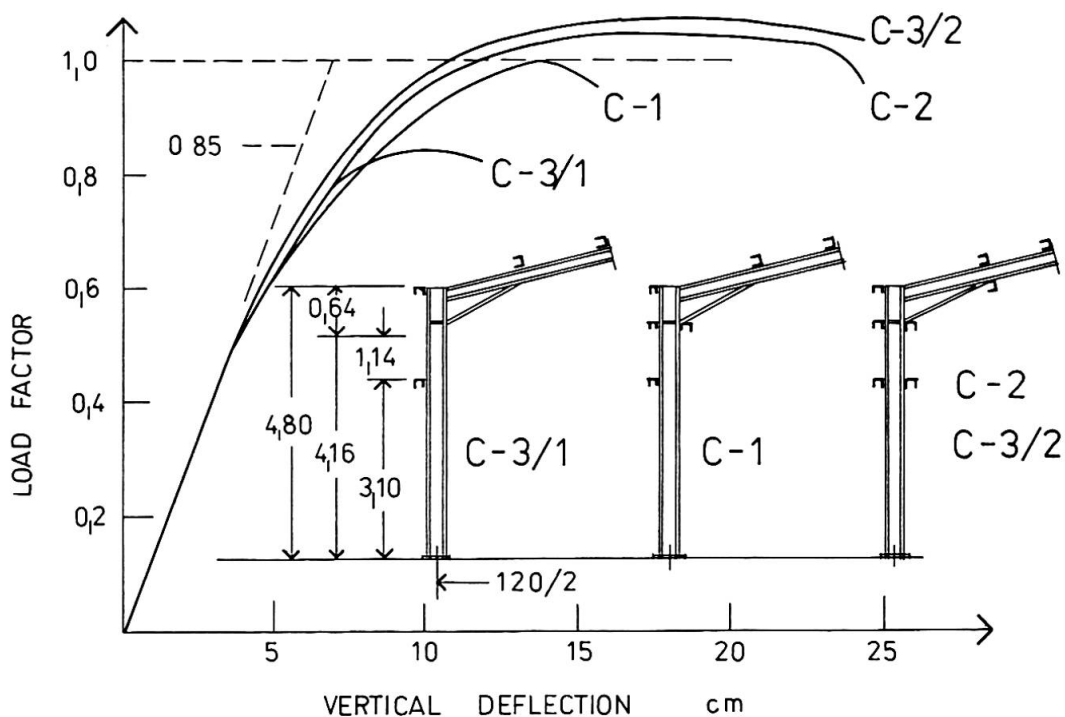

Fig. 4.

/ii/ By repeated cycles of variable loads - for instance by those involving the subsequent application of a light crane-load D and uniformly distributed vertical load P_1 as indicated in Fig. 5, incremental collapse can be produced by a load-factor surpassing but slightly the shake-down load predicted by a first-order ideally elastic-plastic analysis. The difference between test and analytical values was similar to that observed in proportional loading, /due probably to strain hardening/, so the gap between limit loads in proportional and cyclic loading /about 10 % in the case indicated in Fig. 5/ being the same in test and computation for both loading cases.

Surprising was the quick progression of residual deflections after just a few load cycles /see Fig. 5/

- to be attributed possibly to the effect of axial loads connected with remarkable changes in geometry;

- to gradual increase of imperfections /both lateral deflections of beams and curvature of plates/; thus to work-softening effects overcoming the work-hardening ones.

/iii/ In proportional loading axial loads not surpassing 10 % of the elastic critical load had no noticeable effect on limit load as predicted by a simple limit analysis, a finding in good accordance with ECCS rules for plastic design [4]. Excessive initial imperfections - accompanied by 'residual' bending moments as consequence of a forced assembling of the components - may enlarge the diminishing effect of the axial loads.

/iv/ Limits on thickness-to-width ratios to allow full plastic hinge action can be refined by taking into account the interaction between flanges and web.

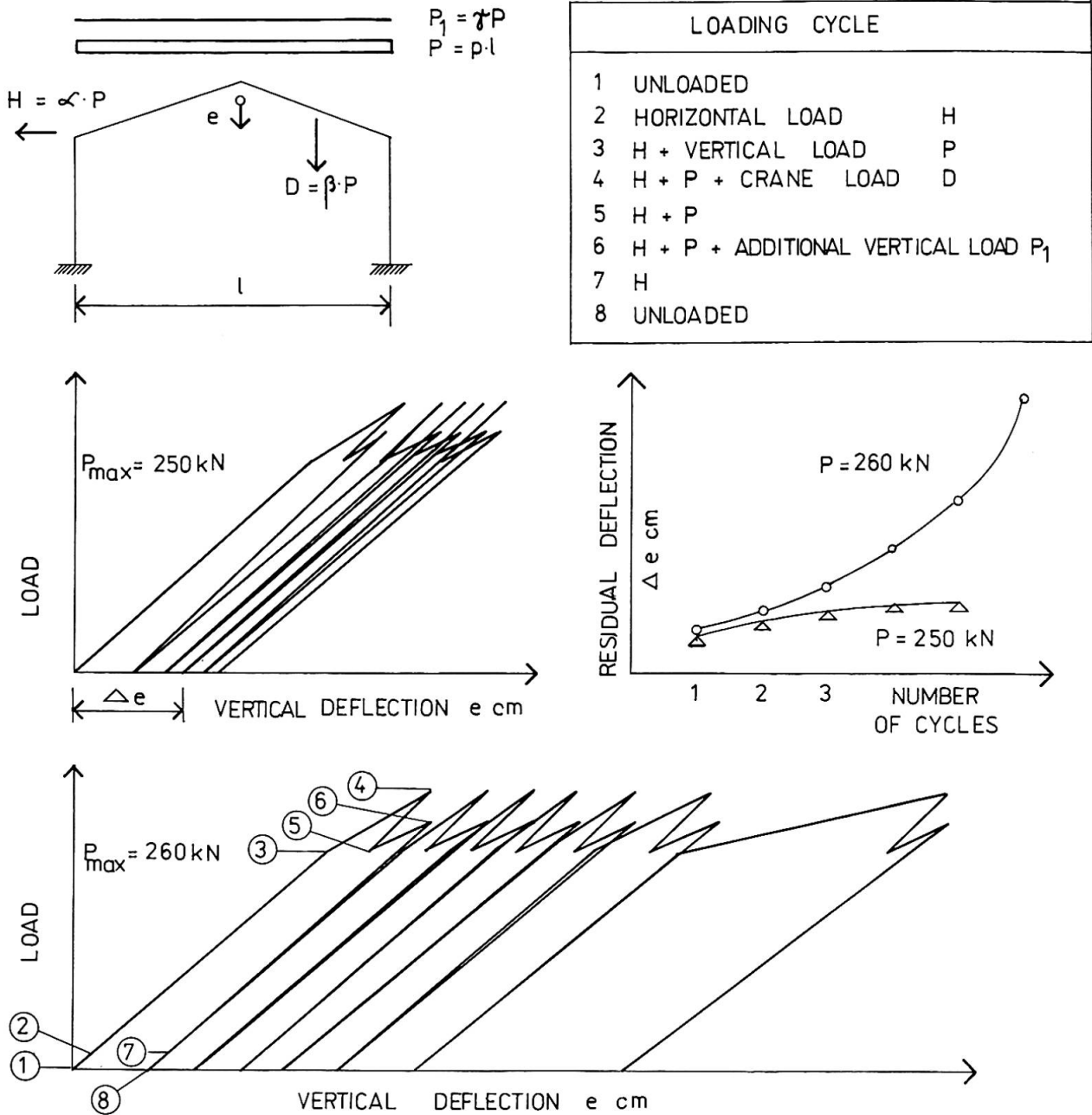

Fig.5.

REFERENCES

- [1] HALÁSZ, O., IVÁNYI, M.: Tests with Simple Elastic-Plastic Frames. Periodica Polytechnica Vol. 3-4. 1979
- [2] HALÁSZ, O., IVÁNYI, M.: Preliminary Studies for the Recommendations for Plastic Design of Steel Structures; Építés és Építészettudomány, Budapest, 1979 /in Hungarian/
- [3] HALÁSZ, O., IVÁNYI, M.: Experimental Research in Plastic Design of Steel Structures. Technical Report I-III. TU Budapest 1976-7ö /in Hungarian/
- [4] ECCS: Recommendations for Steel Constructions 1976.