

Zeitschrift: IABSE congress report = Rapport du congrès AIPC = IVBH
Kongressbericht

Band: 12 (1984)

Artikel: Concrete track systems for maglev vehicles

Autor: Schambeck, Herbert

DOI: <https://doi.org/10.5169/seals-12164>

Nutzungsbedingungen

Die ETH-Bibliothek ist die Anbieterin der digitalisierten Zeitschriften. Sie besitzt keine Urheberrechte an den Zeitschriften und ist nicht verantwortlich für deren Inhalte. Die Rechte liegen in der Regel bei den Herausgebern beziehungsweise den externen Rechteinhabern. [Siehe Rechtliche Hinweise.](#)

Conditions d'utilisation

L'ETH Library est le fournisseur des revues numérisées. Elle ne détient aucun droit d'auteur sur les revues et n'est pas responsable de leur contenu. En règle générale, les droits sont détenus par les éditeurs ou les détenteurs de droits externes. [Voir Informations légales.](#)

Terms of use

The ETH Library is the provider of the digitised journals. It does not own any copyrights to the journals and is not responsible for their content. The rights usually lie with the publishers or the external rights holders. [See Legal notice.](#)

Download PDF: 15.03.2025

ETH-Bibliothek Zürich, E-Periodica, <https://www.e-periodica.ch>

Concrete Track Systems for Maglev Vehicles

Voies en béton pour véhicules à sustentation magnétique

Betonfahrwege für Magnetschwebefahrzeuge

Herbert SCHAMBECK
Dipl.-Ing.
Dyckerhoff & Widmann AG
Munich, FR Germany



Herbert Schambeck, born in 1927, graduated in civil engineering at the Munich Technical University in 1949. Employed by Dyckerhoff & Widmann AG since 1950, he was appointed Director in the headquarters of this company in 1974. He designed widespan industrial buildings and prestressed concrete bridges. Numerous lectures and publications on prestressed concrete Bridges.

SUMMARY

A report is given on the experiences gained in the Fed. Rep. of Germany in the design, construction and operation of concrete track systems for magnetic levitation vehicles. The largest project of this kind is the Emsland Transrapid Test Facility (TVE), whose elevated track system will be approx. 31.5 km long when completed and on which tests will be carried out at speeds of up to 400 km/h.

RESUME

Le rapport fait le point de l'expérience acquise en République Fédérale d'Allemagne dans la conception, l'étude, la construction et l'exploitation de voies en béton pour véhicules à sustentation magnétique. Le projet le plus important est l'aménagement de l'installation expérimentale de la région d'Ems (Transrapid Versuchsanlage Emsland, TVE): une fois terminée, la voie surélevée aura 31,5 km de long et permettra de réaliser des essais de grande vitesse à 400 km/h.

ZUSAMMENFASSUNG

Es wird über die in der Bundesrep. Deutschland bei Planung, Bau und Betrieb von Betonfahrwegen für Magnetschwebefahrzeuge gesammelten Erfahrungen berichtet. Das grösste Vorhaben dieser Art ist die Transrapid Versuchsanlage Emsland (TVE), deren aufgeständerter Fahrweg im Endausbau ca. 31,5 km lang sein wird und auf der Geschwindigkeiten bis zu 400 km/h erprobt werden sollen.



1. GENERAL NOTES

Development of the magnetic levitation technology has been pursued in Germany since 1970 by industry and supported by the Federal Minister of Research and Technology. Initially, work was performed in parallel on the electromagnetic and the electrodynamic levitation technology. A system decision between the two ended in favour of the electromagnetic technology with the two alternatives short stator and long stator as motor. In 1978 the Federal Minister of Research and Technology (BMFT) gave his approval for the design and construction of a test facility in Emsland by a consortium of 7 German companies for a system with long stator (Emsland Transrapid Test Facility = TVE). Essential component of this facility is a test section which when completed will be approx. 31.5 km long and on which speeds up to 400 km/h are to be tested [1].

From the very start of the development of magnetic levitation systems, development of appropriate and economical track systems was pursued in the German construction industry and supported by the BMFT because

- the requirements placed on the track system differ from those for conventional transport systems,

- the costs for the track constitute a very large portion of the overall costs of a new transport system and

- practicable, optimized track structures are a prerequisite for the feasibility of a new transport system.

Track systems for a later operating section will be 1 or 2 track and will be routed on the surface, elevated or in tunnels. Planning work accomplished to date has demonstrated that of these three levels, the elevated track system has the greatest significance because

- through the elevation system, use of the land below the track is practically not obstructed, and this will make it easier to get a new section accepted,

- the loads of magnetic track vehicles are relatively small and accordingly the construction costs of an elevated system are reasonable,

- the vehicle clearance with exterior embracing of the track girder is designed in such a way that the difference between the construction of not elevated and that of an elevated track system is not so significant as with conventional systems,

- the aerodynamical problems connected to high speeds are best solved with an elevated track system. The track equipment is protected against vandalism.

In addition, the alignment elements (radiuses and gradients) are so favourable that the track can to a large extent follow the shape of the land. The resulting uniformity of the structure produces a large rationalization effect.

For these reasons, the track system in Emsland is an elevated structure.

The elevated track can be built in concrete or steel. Tender results with binding bids of competing companies have led to the fact that of the 20.5 km long first construction section of the TVE so far completed, the entire substructure (foundation und columns) as well as approx. 15.5 km of the superstructure have been built in concrete and approx. 5.0 km of superstructure in steel. The test section will be completed in 1985 with an additional approx. 11 km of a second construction section. The design for the second section is compatible with that of the first section, but experiences gained to date have been taken into consideration (Fig. 1).

2. REQUIREMENTS PLACED ON THE TVE TRACK SYSTEM

2.1 Vehicle clearance (Fig. 2)

The vehicle with exterior embracing of the tracks leads to a single-girder system. From the point of view of structural engineering this is superior to a double girder with interior embracing (erected for a test facility built in 1972). The girder dimensions and the possibilities for location of cross girders at the supports are influenced largely by the clearance of the vehicle.

2.2 Equipment of the track system (Fig. 2)

It forms the functional areas for the vehicle. They are

- the stator armature (sa), which in normal operation bears and drives the vehicle,
- the lateral guide rails (lgr) for lateral guidance of the vehicle and
- the sliding skids (ss) in case of lowering of the vehicle when the bearing magnets fail.

The fastening of the equipment to the carcass structure is an important planning element.

2.3 The loads (Fig. 3)

The critical values of the resultant forces from the live loads (ll_1 and ll_2) alone and from the sum of live loads and dead loads of the concrete girder ($dl + ll_1$ and $dl + ll_2$) are entered in Figure 3 for the curve travel with a transverse slope of 12° . The diagram shows that a high dead load acts favourably in this case, since as a result the eccentricity of the resultants from the total loads is reduced and alternating stresses from live loads are decreased.

2.4 Alignment elements

The radiuses in plan and elevation, the gradient, the track twisting and the crossfall are fixed by the alignment. They must be taken into adequate consideration in the track design.

With TVE, the smallest horizontal radius was planned for 1 000 m, the smallest vertical radius for 8 000 m, the largest longitudinal gradient at 3.5 % and the largest crossfall at 12° , the greatest twisting (= change of the crossfall per lin m) is $0.08^\circ/m$.

2.5 Rigidity requirements

Vehicle and track represent a coupled oscillation system, due to which specific character-

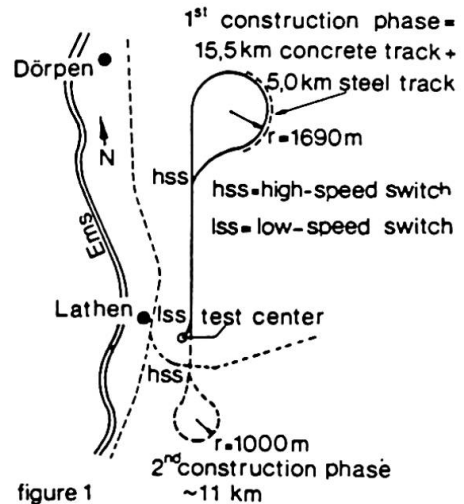

figure 1
The Emsland Transrapid Test Facility (TVE)

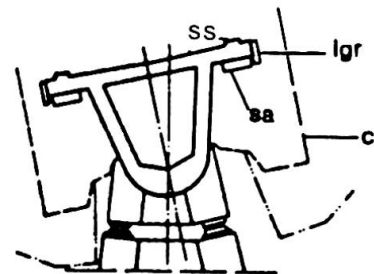

figure 2
Vehicle clearance and equipment of the track

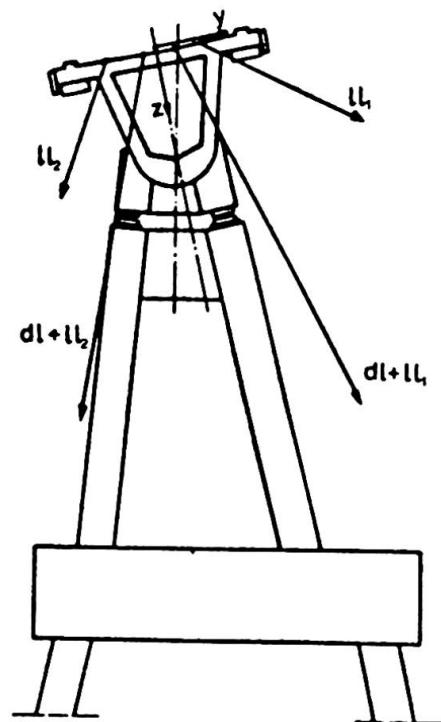

figure 3
loads of the Transrapid test track



istic frequencies and rigidities must be required from the track based on extensive tests and experiments. Here it is critical in particular when the vehicle hovers above the track at low speed or at standstill - that is when starting and stopping. In simplified form it can be stated that these requirements have been fulfilled in the previously built span range of concrete structures when they are designed and dimensioned as prestressed concrete hollow box girders in compliance with the regulations prevailing in bridge building [2, 3].

2.6 Tolerances

The gap width between the magnets of the vehicle and of the track is as a regular case 10 mm. The permissible deviation from this standard gap width and accordingly the permissible deviation of the functional areas from their nominal position are only a few mm. These requirements are considerably more stringent than previously applied in the construction industry; they exercise considerable influence on the design and construction method for the track system.

Specifically, a distinction must be made between

- long-wave dimensional deviations in x, y and z direction (see Fig. 3),
- short-wave dimensional deviations in x, y and z direction,
- dimensional deviations at the joints of the girder ends.

The permissible total tolerances of the functional areas are made up of various influences, namely

- inaccuracies in the fabrication and installation of the equipment,
- deformations resulting from temperature changes in the girder,
- long-term deformations of the concrete girder under permanent loads,
- substructure settlements.

In addition, elastic deformations of the girder under live loads are subject to special limitations.

The tolerances of the carcass structure must be regarded separately from the tolerances of the functional areas. They, too, are considerably smaller than previously practiced in the construction industry. In essence, we differentiate again between the influences stated above. Accordingly the inaccuracies of the carcass structure due to construction must remain small because the existing thin girder structure allows only a few mm of deviations between position of carcass structure and equipment. With respect to deformations, the requirements placed on the carcass structure are more or less identical with the requirements imposed on the functional areas.

2.7 Creative requirements

In the world of today, a new transport system can be realized only if it keeps the associated environmental damages within acceptable limits. One prerequisite for this is that the track system is well designed architecturally. The accompanying picture (Fig. 4) shows that great importance was attached to this aspect for the TVE track system.

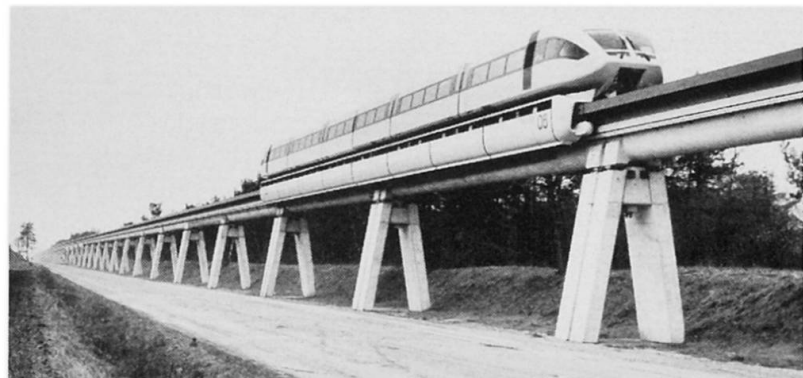

Fig. 4



2.8 Maintenance

The track system, the equipment and their connections must be designed in such a way that a long service life is guaranteed and that the costs for later maintenance are low.

In summary, it can be stated that the requirements placed on the track system - are extremely strict and will produce additional costs in comparison to the otherwise applicable standard in the construction industry. Greater dimensional inaccuracies resulting in a larger gap width between the magnets would consequently lead to higher costs with respect to the vehicle, with respect to system operation and with respect to reduced pay-load capacity. It was the objective of the previous development to establish the requirements placed on the track system that they represent a cost minimum for the overall system.

3. STRUCTURAL CONCEPT OF THE TRACK SYSTEM

The concrete track of the TVE represents a practical and rational design for the given requirements. Its essential features are described and substantiated in the following.

Concrete as building material for the substructure and superstructure provides high dead load and accordingly low load eccentricities in the foundation, provides high rigidity and good vibration absorbing characteristics and consequently insensitivity to vibrations, provides good acoustical insulation, is economical in cost, is available in practically all countries and with professional planning, execution and supervision guarantees low maintenance costs and long operational life.

Tensioning of the concrete is necessary to exclude plastic deformations under permanent loads completely or at least to a large degree. The problem of plastic deformations cannot be solved with reinforced concrete.

The accuracy of the deformation behaviour of the girder is increased by using tendons without relaxation and with very low slippage in the anchorages, by applying an exactly defined concrete mixture and by avoiding construction joints and other inhomogeneities within the girder.

Large precast elements (i.e. jointless production of the entire cross-section over span length) permit mechanization of the construction operations, minimization of costs, high construction speed regardless of weather and high accuracy and material quality.

Single-span girders were selected because the deformation conditions prevailing with the TVE could be fulfilled with single-span girders in post-tensioned concrete and because assembly and disassembly are simple.

The standard span selected was approx. 25 m with a structural height of 1.80 m and approx. 31 m with a structural height of 2.40 m; special spans of approx. 37 m were executed in cast in situ concrete.

A box section for the superstructure produces great bending rigidity in z and y direction and great torsional rigidity (Fig. 3).

Simple compression bearings with prestressing by DYWIDAG tensioning bars were used both for transferring the resultants from the vertical forces and the transversely directed horizontal forces (type 1 according to Fig. 5) and for transferring the brake forces (type 2). They are easy to install, require almost no maintenance and are economically priced. The bearings of type 1 are spread



in transverse direction as far as the vehicle clearance permits. In the longitudinal section, they are located as close as possible to the girder end, because vertical movement of the functional areas at the joint between two girders should be as small as possible.

Columns designed as an A-frame transfer the large horizontal forces of the superstructure safely into the foundations.

A pile foundation assures minimum foundation settlements despite poor subsoil conditions existing in Emsland.

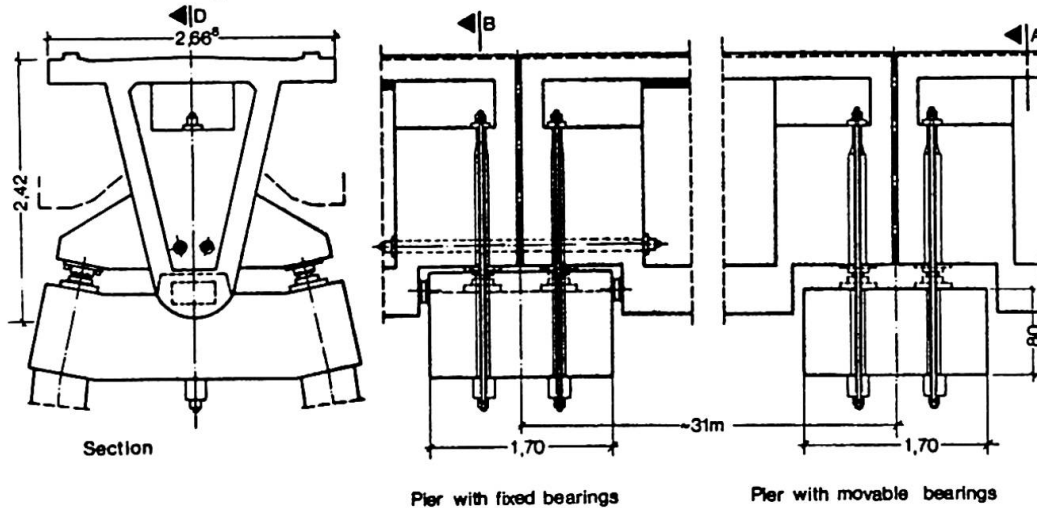

figure 5
Bearings of the 31m girder in the 2nd construction section

Separation of the production of the carcass structure and the equipment was consistently maintained to permit greater production tolerances in the carcass construction than in the functional areas and to assure that the initial deformations of the concrete do not influence the accuracy of the functional areas' position. There are 2 different methods:

With the first method, the equipment is assembled with the aid of a placing train and supplementary facilities after the track girder has been finely adjusted on the columns. The method has the advantage that the dimensional tolerances of the functional areas are not influenced by the inaccuracies in adjusting the carcass structure. It has the disadvantage that tolerances for deformations of the girder under the load of the placing train and as a result of temperature conditions must be taken into consideration during assembly of the equipment.

With the second method, the equipment is assembled in a shop under controlled temperatures and with a device which does not load the girder before placing of the girder. The equipment assembly is not dependent on the weather. The tolerances for the fine adjustment of the completely equipped girders now influence the tolerances of the functional areas in operating condition.

Fastening the stator armature and lateral guide rails to the concrete girder can be made according to two different systems.

In the first system, recesses are provided in the concrete girder, into which fastening devices for the stator armature and the lateral guide rails are subsequently inserted and grouted with fast-setting mortar.

In the second system, steel elements are cast into the girder during production of the girder. Threads are then drilled into these steel elements immediately before placing the equipment.

The sliding skids on top of the girder are produced together with the remaining structural concrete - that is initially with larger tolerances - and later grinded down to exact nominal position.

Adjustment possibilities are provided by bearings which with the aid of hydraulic jacks and by insertion of washer plates can be adjusted in all 3 directions.

In addition, tendons without bond can later be installed inside the girder box, allowing to control deformation of the girder through a freely selectable tensioning force.

4. CONSTRUCTION PERFORMANCE

For the Emsland Transrapid Test Facility (TVE), cast in situ concrete proved to be the most practical and most economical solution for the foundations and the piers including the pier heads [4].

Parallel to the production of the substructures, production of the track girders was carried out in a field plant in the vicinity of the project site.

The first step in the girder production was the pre-fabrication of the reinforcing cage (RC) in a separate work shop ①.

The reinforcing cage already contained the recoverable interior formwork (IF) shaping the inside of the box girder. The reinforcing cage was then transported into the concreting work shop where it was lifted into the exterior formwork (EF) ②.

Three exterior formworks were available. After overcoming the initial period for starting construction, one standard girder was cast per day in each exterior formwork ③.

Following a heat treatment of the newly cast concrete, a partial posttensioning was applied as early as 16 hours after concreting so that the girder could be lifted out of the formwork and placed on the storage yard ④.

After final posttensioning, after installation of transverse diaphragms at the girder ends and after at least 2 months of storage for fading of initial deformations due to creep and shrinkage, the girder was transported with heavy lorries to the installation site ⑤.

The girders were initially placed with cranes onto temporary bearings and later precisely positioned in an independent operation; special hydraulic jacks were used for this purpose which permitted movements in all directions and which carried the girder until the bearings had been finally adjusted.

The stator armature and the lateral guide rails were then installed in sections of about 12,5 m length using the above described method 1 with a placing train. The sliding skids were brought to their final level with the aid of the grinding vehicle.

All construction work was accompanied by a program of extensive and expensive surveying work.

The above described construction method is adapted to the given project - that is building approx. 15 km of track in well accessible terrain. For larger track lengths in difficult terrain, an alternative placement method was developed moving precast elements over the previously placed girders.

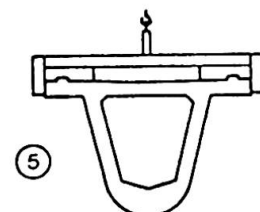
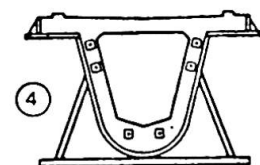
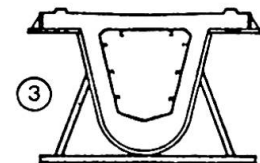
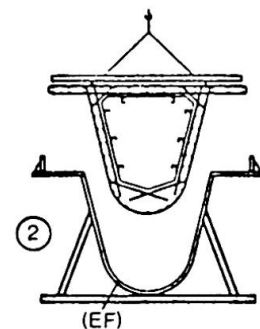
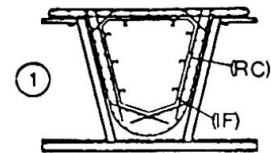

figure 6
Production of the 25m
girder as prestressed
concrete precast element



5. CHARACTERISTICS OF THE FINISHED TRACK

Adherence to the tolerances, shapes and dynamic properties required in the specifications was checked by various measurements.

Deformation measurements under static load showed that the actual rigidity of the girders is somewhat greater than that required and that the deviation range of these measurements is very small.

Long-term measurements were made both before and after installation of the equipment on the girder. The measurements taken before installation of the equipment were used for the definitive fixing of the vertical position of the equipment at the time of installation. Measurements made after installation of the equipment confirmed that in this condition the sustained exterior loads and the deflection forces of the tendons are optimally matched to each other and that therefore the plastic deformations are almost zero up until now.

Temperature measurements likewise produced the result that the temperature differences between the top and bottom of the girder assumed in the calculation have in actual practice not been exceeded.

The acceptance measurements for checking the position accuracy of the equipment were initially made section by section and thereafter continuously by means of a test vehicle. The vehicle itself - which is 54,2 m long, consists of 2 units, can accommodate 98 persons per unit and is called TR 06 - is also equipped with a measuring device, with which the position accuracy of the functional areas can be recorded during the test runs.

Dynamic tests for determination of the lowest inherent frequencies, of the accompanying inherent deformations and of the absorber capacity showed that the natural frequency of the basic oscillation is 5.8 Hz for the 31 m girder and thus comes very close to the calculated value. The absorber capacity - expressed by the logarithmic decrement of successive amplitudes in the fading process - can be assumed at $\lambda = 0.1$ to 0.2. The relatively high absorber capacity compared to known values for bridges appears to be due to the fact that the foundation is also participating in the vibrations.

6. PARTIES INVOLVED

The Transrapid Test Facility Emsland (TVE) has been designed and executed by a consortium of the companies AEG, BBC, Dyckerhoff & Widmann, Krauss-Maffei, MBB, Siemens, Thyssen Henschel and is sponsored by the Federal Minister of Research and Technology. The parts of the test facility constructed in concrete have been designed and erected by Dyckerhoff & Widmann AG assisted by other German construction companies. Once completed, the test facility will be taken over by the newly established company MVP (constituted by representatives of Deutsche Bundesbahn, Lufthansa and IABG) for experimental operation.

REFERENCES

- [1] HILLIGES, D., MÖLZER, P., RASCHBICHLER, H.-G. and ZUREK, R.: Der Fahrweg der Transrapid Versuchsanlage Emsland, ZEV-Glas.-Ann. 105 (1981), No. 7/8
- [2] HILLIGES, D.: Fahrwege für Magnetschwebefahrzeuge unter dynamischer Beanspruchung, Bauingenieur 51 (1976), p. 337-347
- [3] HILLIGES, D.: Dynamik von Magnetbahnfahrwegen in Betonbauweise, Meßergebnisse und ihr Einfluß auf den Entwurf, VDI-Reports No. 510, March 1984, p. 107-113
- [4] LÖNNECKE, K. H. and STÜBEN, H. H.: Bauausführung des Betonfahrweges der Transrapid Versuchsanlage Emsland, Bauingenieur 58 (1983), No. 4
- [5] Inst. f. Building Materials, Solid Construction and Fire Protection at the Braunschweig Technical University: Schwingungsmessungen am Betonfahrweg der Transrapid Versuchsanlage Emsland, Untersuchungsbericht No. 83 063 -Pm/br, 1.2.1983