

Zeitschrift: IABSE congress report = Rapport du congrès AIPC = IVBH
Kongressbericht

Band: 12 (1984)

Artikel: New design method of space structures using beam-like lattice trusses

Autor: Suzuki, Toshiro / Ogawa, Toshiyuki / Takeuchi, Tooru

DOI: <https://doi.org/10.5169/seals-12184>

Nutzungsbedingungen

Die ETH-Bibliothek ist die Anbieterin der digitalisierten Zeitschriften. Sie besitzt keine Urheberrechte an den Zeitschriften und ist nicht verantwortlich für deren Inhalte. Die Rechte liegen in der Regel bei den Herausgebern beziehungsweise den externen Rechteinhabern. [Siehe Rechtliche Hinweise.](#)

Conditions d'utilisation

L'ETH Library est le fournisseur des revues numérisées. Elle ne détient aucun droit d'auteur sur les revues et n'est pas responsable de leur contenu. En règle générale, les droits sont détenus par les éditeurs ou les détenteurs de droits externes. [Voir Informations légales.](#)

Terms of use

The ETH Library is the provider of the digitised journals. It does not own any copyrights to the journals and is not responsible for their content. The rights usually lie with the publishers or the external rights holders. [See Legal notice.](#)

Download PDF: 15.03.2025

ETH-Bibliothek Zürich, E-Periodica, <https://www.e-periodica.ch>

New Design Method of Space Structures Using Beam-like Lattice Trusses

Nouvelle conception de structures spatiales, avec des fermes à treillis de type poutrelle

Ein neuer Typ von Raumtragwerken aus Gitterträgern

Toshiro SUZUKI

Professor
Tokyo Inst. of Technology
Tokyo, Japan



Toshiro Suzuki, born 1936, obtained his doctor of engineering degree at the University of Tokyo, Tokyo, Japan. His major research activities include strength of steel structures, plastic analysis, buckling and ultimate strength of structures, and he is now joint head of the Department of Architecture and Building Engineering.

Toshiyuki OGAWA
Res. Assoc.
Tokyo Inst. of Tech.
Tokyo, Japan

Tooru TAKEUCHI
Grad. Stud.
Tokyo Inst. of Tech.
Tokyo, Japan

Kunio UKAI
Deputy Repr.
Nikken Sekkei Ltd.
Osaka, Japan

Masahiro KATO
Struct. Eng.
Sumitomo Metal Ind.
Tokyo, Japan

SUMMARY

The paper aims at developing a new design method for steel roof structures of large span by using long beams formed of three dimensional trusses. The mechanical properties of these trusses are discussed in terms of experimental results and analyzed by means of continuum theories.

RESUME

L'article présente une nouvelle conception de structures pour des toitures en acier de grandes portées, utilisant de longues poutrelles constituées de fermes à treillis tridimensionnels. Les propriétés mécaniques de ces fermes à treillis sont exposées au moyen de résultats expérimentaux et d'analyses réalisées avec les théories du continuum.

ZUSAMMENFASSUNG

Der Beitrag beschreibt die Entwicklung einer neuen Dachkonstruktion für grosse Spannweiten durch die Verwendung von Raumfachwerkträgern. Die Festigkeitseigenschaften der Fachwerkträger werden anhand experimenteller Ergebnisse diskutiert und mit der Kontinuumstheorie analysiert.

1. INTRODUCTION

At present, convenient and popular structures for covering the roofs with large spans are plane lattice trusses or space frames. As a method contrary to this, we develop a new design method of roof structures using long beams constituted with three dimensional trusses (beam-like lattice trusses) in one direction. The abstract model of beam-like lattice trusses are shown in Fig.1.

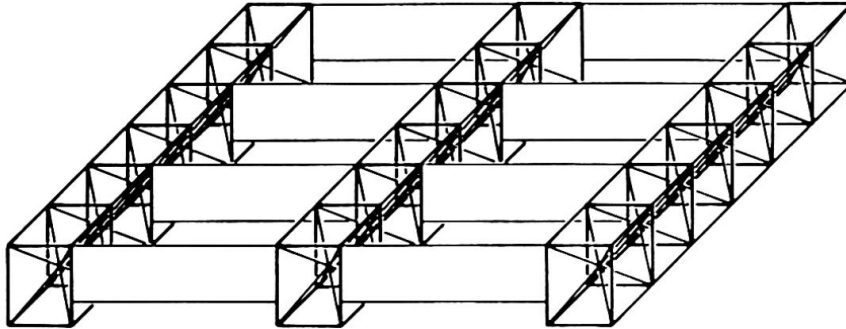

Fig. 1 Wide-span structures using beam-like lattice trusses

The design method of roof structures by beam-like lattice trusses has the following merits.

- Beam-like lattice trusses have higher strength for lateral buckling as a beam than plane lattice trusses. So they can cover a very large span without lateral restriction.
- This type of structure is quite simple in dynamics because whole structure has the form of simple beam. Complicated analysis as for space frames is not required.
- It is superior in productivity and constructiveness because the structural elements are clearly separated. It is easy to arrange for irregular plans for the same reason.
- This design can be economic and good in shape by arranging the truss members of the beam effectively.

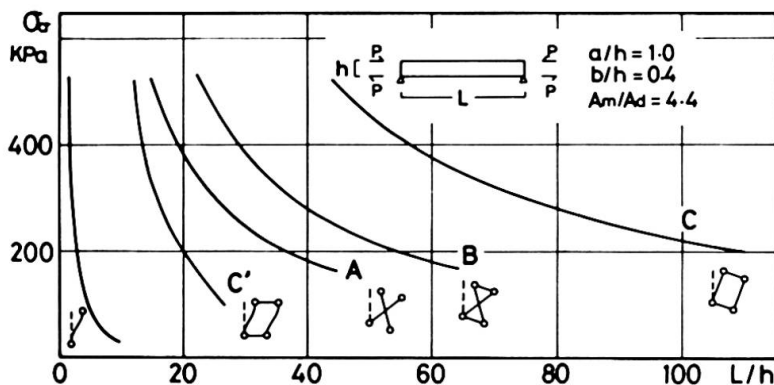

Fig. 2 Lateral buckling strength of lattice beams

The relationship of lateral buckling strength and span of these beams under pure bending are shown in Fig. 2. The lowest curve is that of plane lattice truss, and curves A, B and C are those of beam-like lattice trusses. As is evident from Fig.2, these beams are much stronger for lateral buckling in comparison with plane lattice truss.

In designing this beam-like lattice trusses, the design method of plane lattice can be applied in general, but the design of web members is an exception. In designing web members of plane lattices, only shearing is considered. But, not only bending but torsion act on these beams when vertical load works on one side of the beam, or shear load works on the whole structures by earthquake and wind. Especially, the deflection and the strength of the beam is affected remarkably by torsional load when the beam becomes long. So the design of web members considering shearing and torsion is indispensable in designing beam-like lattices.

In the present paper, for these reasons, we try to comprehend the characters of beam-like lattice trusses under shearing and torsion, and develop the effective design method of web members. This study consists of the following items.

- Design philosophy of the model beams.
- Character of the beams under torsion.
- Character of the beams under shearing and torsion.
- Effective design method of web members.

2. DESIGN PHILOSOPHY OF THE MODEL BEAMS

We set up three type of beams shown in Fig. 3 as definite model to make clear the effect of web members. The design philosophy of these beams are described as follows.

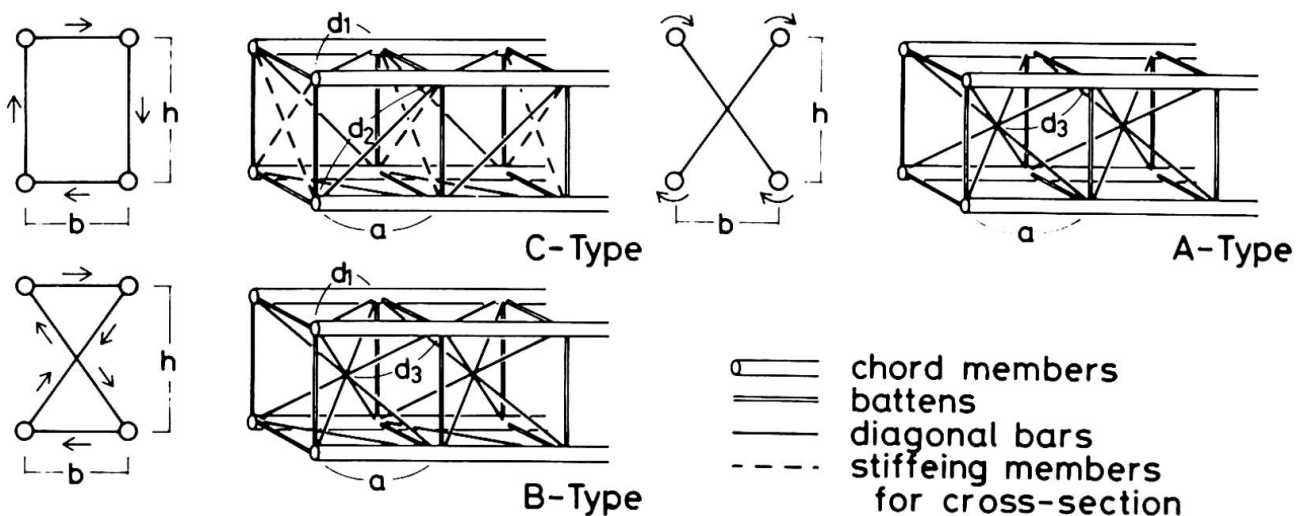

Fig. 3 Models of lattice beams composed of several members

The beam of C-type is the box-section, and has the form of two plane truss beams laced by level diagonal bars. Though these beams are generally designed as only two abreast plane beams against torsional load, the level diagonal bars can be made best use of by stiffening cross-section with cross diagonals and unite the whole beam.

The beam of B-type is trying to save the members by concentrating the vertical diagonal bars to the center of each bay, and serving both as a vertical web members and a stiffening members for cross-section. In addition, it is trying to raise the shearing strength of the whole beam by shortening the buckling length of the web members.

As for the beam of A-type, the level diagonal bars are removed from B-type, and the concentrating diagonal bars resist all directional shearing. The number of the bars of this type is about 1/3 of those of box-section which has the same shearing stiffness in all direction.

3. CHARACTERS OF THE BEAMS UNDER TORSION

3.1 Comprehension by the continuum theory

At first, characters of these model beams under only torsion are discussed. The torsional characters of these trusses are explained by the continuum theory as follows. The beams of C-type and B-type correspond to the closed section, and the axial forces of the diagonal bars resist the torsional moment as shear flow. On the other hand, the beams of A-type correspond to the open section, and the torsional rigidity of the whole beam owes to that of each chord members. From this an idea comes into being that the torsional rigidity of the beam can be insured by using the chord members which have high rigidity in themselves. From this, the design using steel tubes for chord member will be effective in this type. Because of the difference of axial force distribution, the collapse form of closed section under torsion is expected to be different from that of open section, too. The beams of closed section, as for C-type and B-type, are expected to collapse with rupture or buckling of the diagonal bars. The beams of open section, on the other hand, are expected to break with torsional failure of the chord members, or with bending failure of the web members. The torsional strength of these beams are obtained from the continuum theories.

3.2 Model experiments

We carried out model experiments under torsion on three kinds of the beams of type A, B, C. The specimens consist of the following factors.

All specimens consist of three bays of the beams.

The specimens are fixed at on side with no warping, and torsional moment are caused to act on the other side with the condition free to warp.

All specimens are made up with steel tubes. Chord members are straight and diagonal bars are connected with chord members with welded joint.

The view of the experiment is shown in Fig. 4.

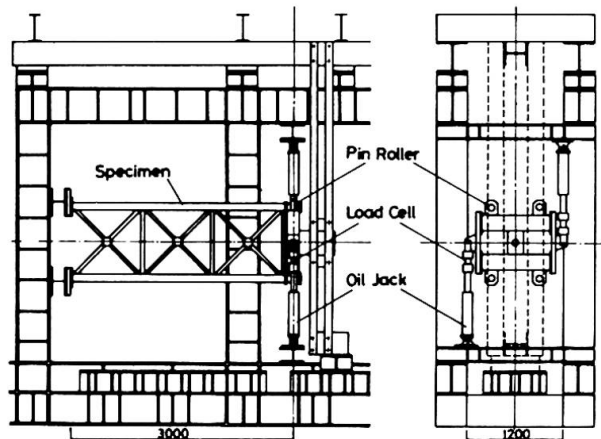

Fig. 4 Set-up of model experiment under torsion

Besides this experiment, the stress distribution and the deflection of these beams under torsion are analyzed with the finite element method (F.E.M.). The characters of these beams under torsion made clear by the continuum theory, the experiments, and the F.E.M. analysis are discussed as described later. The relationship of load-deflection given by this experiment and the continuum theory are shown in Fig. 5. In them, loads, torsional moment, are given by the product of the breadth and the shear strength of the beam, and deflections, angle of torsion, are given by the breadth. The beam of C-type and B-type broke with the rupture of the diagonal bars shown with the mark "▽" in the figures. Contrary to this, the beam of A-type collapsed with bending yield of the battens and has conspicuously different load-deflection curve from that of B-type which is the beam added diagonal bars on upside and downside to A-type.

The distributions of axial forces of the members of these beams under the unit torsional moment given by the experiment, the F.E.M. analysis, and the continuum theory are shown in Fig. 6. They give the relationships of axial force of the diagonal members and the distance from the fixed end of the beam. As is evident from this figure, the beams of C-type and B-type, the closed sections, resist the torsional moment with axial forces of the diagonal bars and contrary to this, little axial forces generated on A-type, the open section.

From the results described above, it became evident that the stress distribution and the form of collapse of beam-like trusses under torsion is conspicuously different between the closed section and the open section, and these characters are explained exactly by the continuum theory.

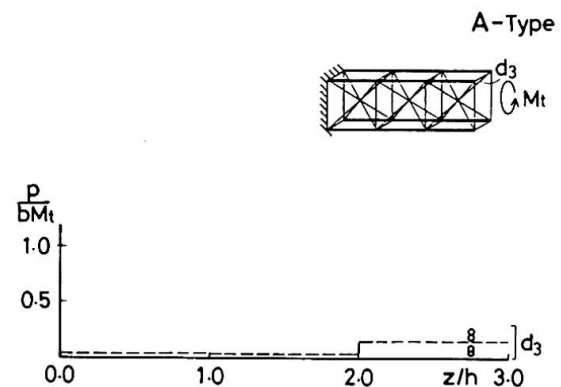
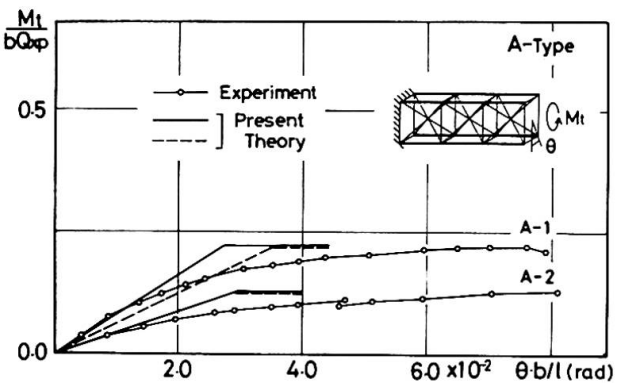
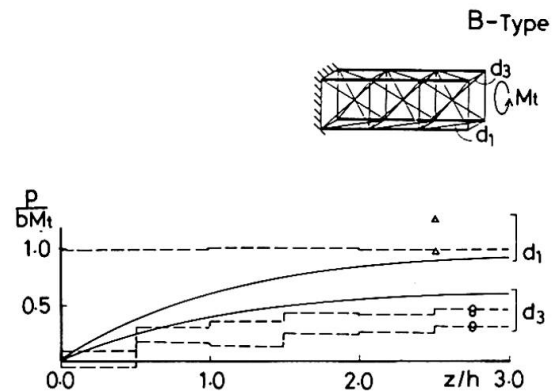
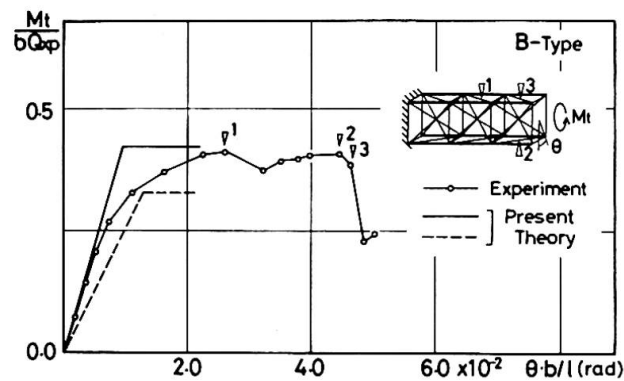
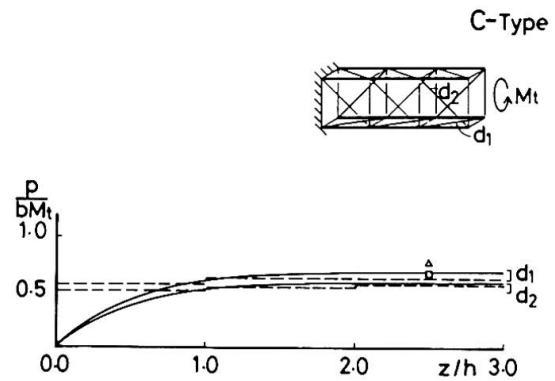
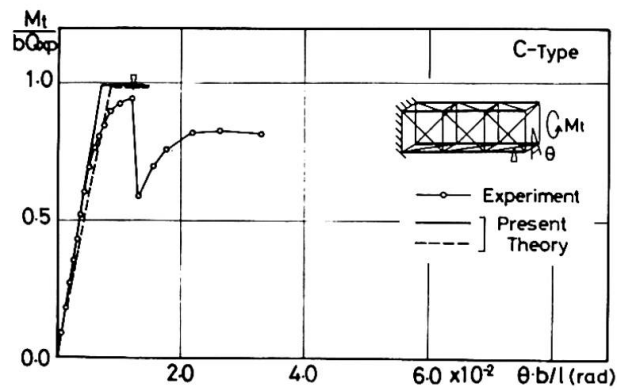

Fig. 5 Torsional moment v.s. torsional angle relationship

Fig. 6 Axial forces on diagonal members

4. CHARACTERS OF THE BEAMS UNDER SHEARING AND TORSION

4.1 Comprehension by the continuum theory

In this section, we discuss the characters of beam-like lattice trusses under shearing in addition to torsion. This problem is typified by that of the beam under eccentric load, as in Fig. 7.

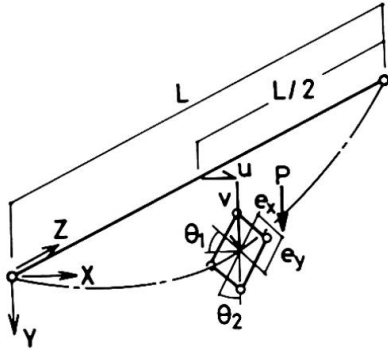

Fig. 7 Lattice beam under eccentric load

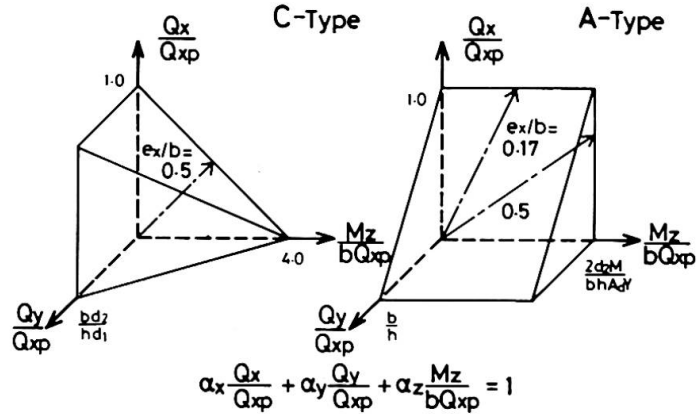

Fig. 8 Failure criteria of lattice beams

We selected the beam of C-type and A-type as specimens, which are typical as closed section and open section respectively. The failure criteria of C-type and A-type are shown in Fig. 8. Q_x , Q_y , M_z mean respectively shearing loads with respect to strong axis, shearing loads with respect to weak axis, and torsional moment, and each axis is given by the shearing strength with respect to the strong axis without eccentricity. This figure means that the beams collapse when the condition of loads reach these surfaces. As for C-type, the closed section, the strength under shearing loads and that of torsional moment interacts each other because the torsional moment produces axial forces on diagonal bars which resist the shearing loads. Contrary to this, as for A-type, the open section, the strength under these loads are independent because no axial forces are produced in the diagonal bars by torsional moment. The path of loads condition under eccentric bending load are shown in the figures.

4.2 Model experiments

We carried out model experiments under torsion and bending on two kinds of the beams, A-type and C-type. The specimens consist of the following factors.

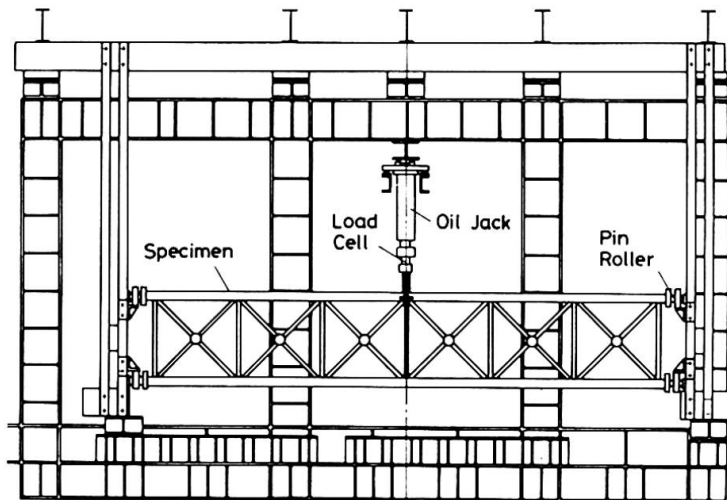

Fig. 9 Set-up of model experiment under torsion and bending

-All specimens consist of six bays of the beams. Their construction are equal to those of the experiments of torsion, described in 2.2.
 -The specimens are simple-supported and eccentric loads are applied on the center of these beams. The load points are free to move horizontally according to the revolution of the section of the beams.
 The view of the experiment is shown in Fig. 9.

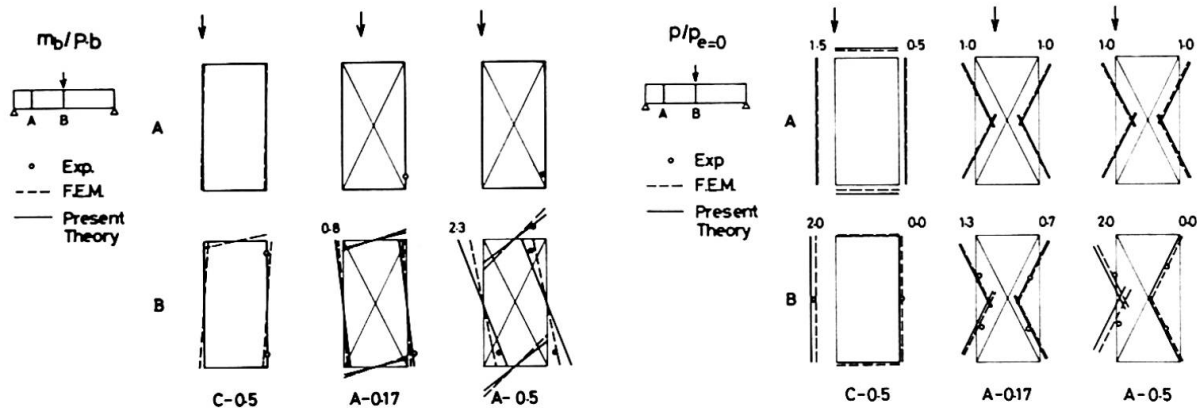

Fig. 10 Axial forces on diagonal members

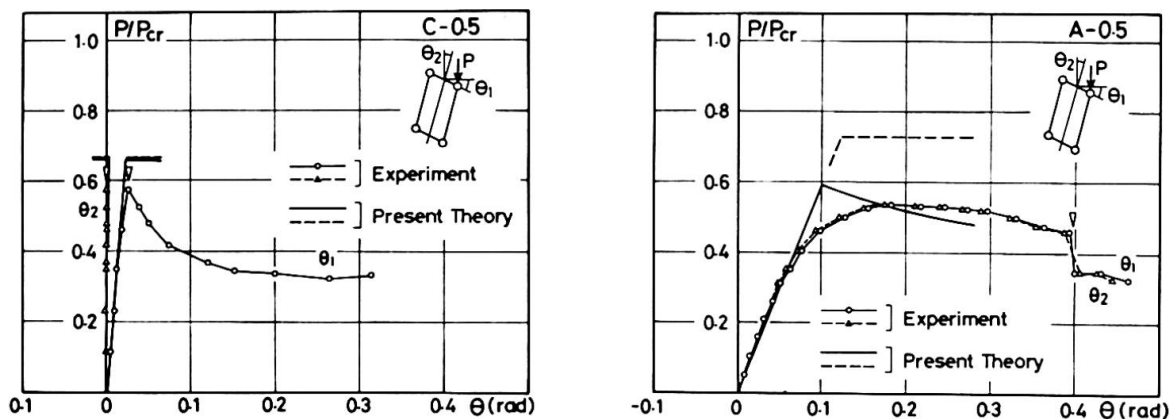

Fig. 11 Concentrated load v.s. rotation of central section relationship

The stress distributions of the diagonal bars of these beams under the unit eccentric load obtained by the experiment, the F.E.M. analysis, and the continuum theory are shown in Fig. 10. The figure shows axial forces of the diagonal bars and bending moments of the battens, severally at the center and the section at intervals of two bays from the center. What is evident from these figures is that the reaction against bending and torsion are divided severally by the diagonal bars and the battens in the open A-type, contrary with the closed section C-type, in which both bending and torsion are born by the diagonal bars.

The relationships of load-rotation of central section obtained by this experiment and the continuum theory are partially shown in Fig. 11. In them, loads are given by the shearing strength of the beam with no eccentricity. The beam of C-type broke with the buckling of the diagonal bars and the load falls rapidly. Contrary to this, A-type under the same condition broke with the bearing yield of the battens and had superior deformation capacity, which is important in the earthquake and wind resistant design. Adding to this, A-type has the strength almost equal to C-type under bending and torsion though it is inferior under torsion only. These characters are because of the wide distribution of the stresses, and they can be considered as common characters to the open section. The final view of the experiment is shown in Photo. 1.

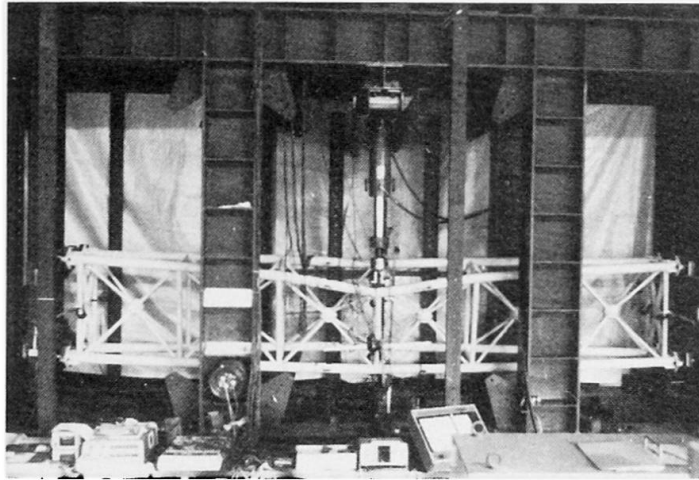

Photo. 1 Final view of specimen

5. EFFECTIVE DESIGN OF THE BEAM

Special merits of the steel roof structures by beam-like lattice trusses and the mechanical properties of these beams are discussed. By using these results, effective design for large span can be developed. For example the beam of A-type, set up in this study, is proved to have excellent characters as follows.

- Diagonal bars concentrating to the center of each bays resist all directional shearing, and number of the diagonal bars of this type is saved to about 1/3 of those of box-section which has the same shearing stiffness in all direction.
- This type of beam has a good appearance because of the radial bars in its each bays.
- The torsional rigidity of whole beam is insured by using steel tubes for chord members.
- Because of the wide distribution of the stresses, the strength of this type under shearing and torsion is not inferior to that of box-section inspite of saving members.
- A beam of this type has superior deformation capacity when it collapses with bending yield of battens. This cahracter is important in the earthquake and wind resistant design.
- For the case where high torsinal rigidity should be needed, this type can easily cope with the situation by adding diagonal bars on its upside and downside and changing it into B-type.

REFERENCES

1. NAN S.S., Torsional Analysis for Suspension Bridges. Proc. of ASCE, Vol.83, No. ST6, 1957.
2. S.KOMATSU and N.NISHIMURA, Three Dimensional Analysis of Truss Girders by the Thin Walled Elastic Beam Theory. JSCE, No.238, June, 1975.
3. A.K.NOOR and C.M.ANDERSON, Analysis of Beam-Like Lattice Trusses. Computer Methods in Applied Mechanics and Engineering, 20, 1979.
4. T.SUZUKI and M.KIMURA, Behavior of Steel Beams under Eccentric Lateral Load. Transactions of Arckitectoral Institute of Japan, May, 1976.
5. T.SUZUKI and T.TAKEUCHI, Tortional and Lateral Buckling of Three-Dimensional Truss Beams. Summaries of Technical Papers at 1983 Annual Meeting of Archt. Inst. Japan.