

Zeitschrift: IABSE congress report = Rapport du congrès AIPC = IVBH
Kongressbericht

Band: 14 (1992)

Artikel: Impact of the maritime ports on the environment

Autor: Ciortan, Romeo

DOI: <https://doi.org/10.5169/seals-13794>

Nutzungsbedingungen

Die ETH-Bibliothek ist die Anbieterin der digitalisierten Zeitschriften. Sie besitzt keine Urheberrechte an den Zeitschriften und ist nicht verantwortlich für deren Inhalte. Die Rechte liegen in der Regel bei den Herausgebern beziehungsweise den externen Rechteinhabern. [Siehe Rechtliche Hinweise.](#)

Conditions d'utilisation

L'ETH Library est le fournisseur des revues numérisées. Elle ne détient aucun droit d'auteur sur les revues et n'est pas responsable de leur contenu. En règle générale, les droits sont détenus par les éditeurs ou les détenteurs de droits externes. [Voir Informations légales.](#)

Terms of use

The ETH Library is the provider of the digitised journals. It does not own any copyrights to the journals and is not responsible for their content. The rights usually lie with the publishers or the external rights holders. [See Legal notice.](#)

Download PDF: 08.02.2025

ETH-Bibliothek Zürich, E-Periodica, <https://www.e-periodica.ch>

Impact of the Maritime Ports on the Environment

Impact des ports maritimes sur l'environnement

Umweltbelastung von Seehäfen

Romeo CIORTAN

Assoc. Prof.
Design Inst. for Transport
Bucharest, Romania



Romeo Ciortan, born 1941, received his civil engineering degree at the Civil Engineering Institute Bucharest, Romania. He was involved in special problems for hydrotechnical construction. Now he is responsible for the design of port construction development, coastal engineering and shipyards.

SUMMARY

Along a great part of its length, the Romanian seashore feels the influence of ports. Fighting with many negative phenomena has imposed steps concerning the ways and means of work operation in order to protect the environment.

RÉSUMÉ

Sur une grande partie de sa longueur, le littoral roumain met en valeur l'influence des ports. La confrontation avec de grands phénomènes négatifs a imposé des mesures concernant la conception et le mode d'exploitation des ouvrages pour la protection de l'environnement.

ZUSAMMENFASSUNG

Ein Grossteil der rumänischen Küste spürt die negativen Folgen der Seehäfen. Die Bekämpfung zahlreicher Emissionen resultierte in Massnahmen; in Konzeption und Betrieb der Anlagen zum Schutz der Umwelt.



1. GENERAL

The world ocean plays an important part to the climate formation, treats a great quantity of oxygen and is very important for life maintaining on the earth. Also very important are the resources constituting food production. The sea and ocean pollution is a major problem and has negative effects on fish production, degrading the shores having negative effects on the people's health. That is why this aspect is in the attention of international forums and of those governments of countries opened to naval ways transports.

As for the Romanian seashore of the Black Sea, on its whole length of 245 km we feel the influence of the land seronqly. A specific problem is that of seashore arrangements wich have known an important development during the last two decades.

Thus we have finalized the arrangements of harbours Constantza, Midia and Mangalia as well as the breckwaters and some interior arrangement works of Constantza South harbour in wich the Danube-Black Sea canal outlets. (fiq.1)

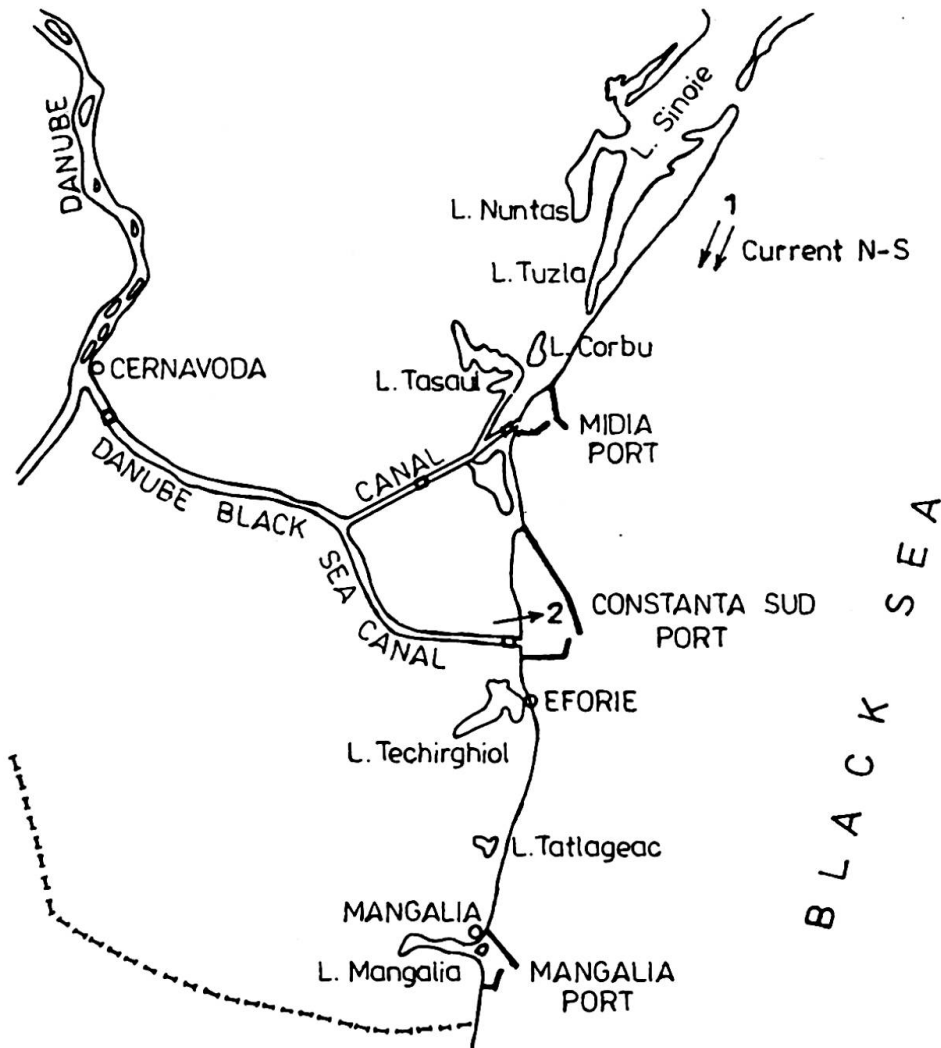

Fig.1 -Ports on the Romanian seashore of the Black Sea
1-current N-S; 2-waste sewerage



The harbour enclosure was achieved whose total surface is of about 4,000 ha with lengths of panning fronts of about 20,000 m to which land more than 800 ships respectively 3,500-4000 ships annually with a traffic of over 150,000 t daily solid and liquid products.

To this activity we must add the one the three shipyards of the three harbours that are being constructed and where a great number of ships are repaired. On this ports over 30,000 employers are working.

The length of the seashores has grown from 5,000 m in 1965 to about 17,000 m at present but their effects is felt on a greater area.

2. EFFECT OF HARBOUR WORKS ON THE ENVIRONMENT

The presence of the harbour works is felt under the following aspects:

- disturbance of the alluvial current N-S is interruption where the works advance into the sea thus obstructing the natural alimentation of the upstream side.
- generalization of littoral corosions as a result of what we have presented.
- influence over sea flowers and animals as a result of the destruction of some mollusks useful for maintaining the sea animals and the fish production the sea water filtration and the generation of skill sand which is an important feeding source for seashore.
- the penetration of salted water from the sea along the canal affecting the sweet phreattic nappe and the agricultural products
- the pollution of air soil and water due to the specific activity and to the technological and accidental losses which if we consider of only 0.5-1% of the goods volumes, we may obtained daily waste of 100-150 t which pollutes the ship enclosure with metal ions carbon dust or solid and liquid chemic products. To all these there are some additional deficiency that may appear in time to the waste water collecting pipes.

3. SOLUTIONS FOR THE REDUCTION OF THE ECOLOGIC IMPACT OF THE HARBOUR ARRANGEMENT

The solutions proposed for the reduction or compensation of the defavorable course concerning the environment must concerning the specific harbour activity.

In the case of the Romanian harbours and especially of the case of the Constantza harbour (fig.2), we present some solutions in order to limit the negative effect of these arrangements over the environment.

That is about the work conceiving and about the harbour enclosure exploiting.

There have been provided measures in order to limit the polluting effects for each sector of activity, by using closed systems transports, by watering the waste dump of ore and carbon, by using the installations which retain the dust from cereals, cement or chemic products.

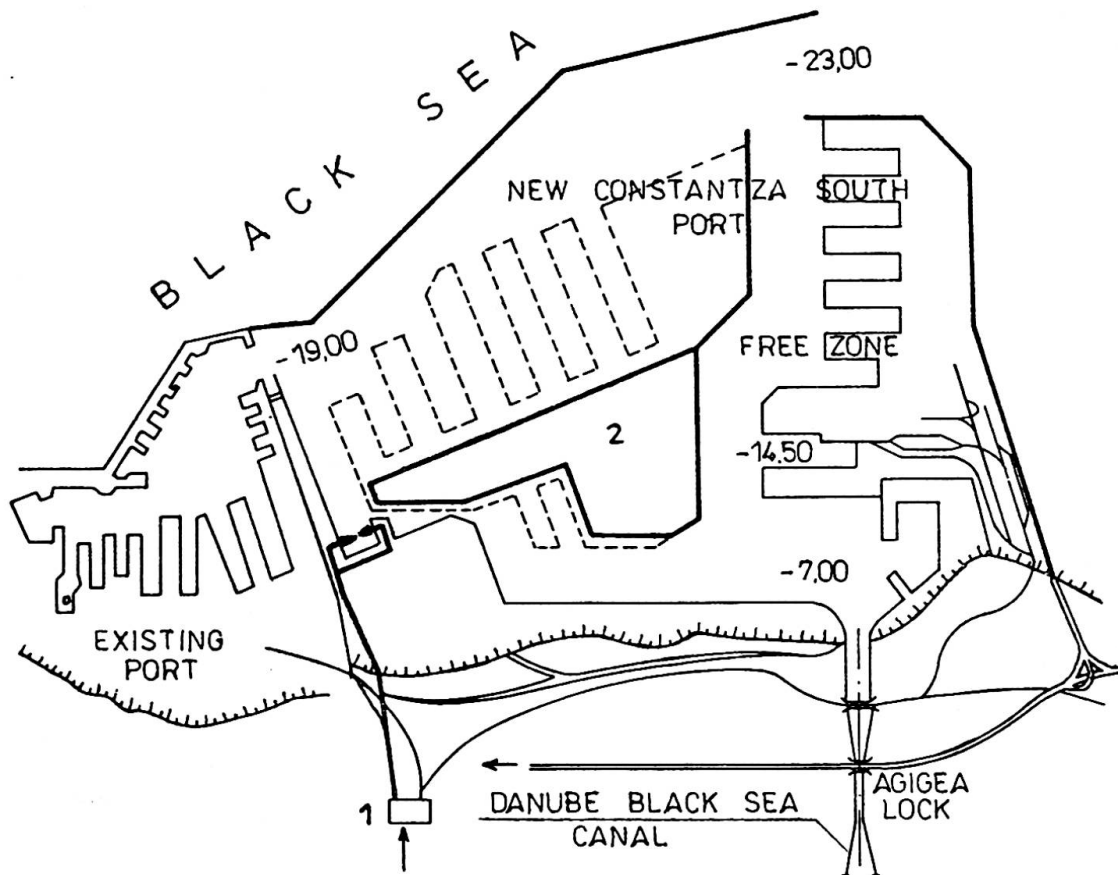

Fig.2 Constantza port
1-water treatment station; 2-enclosure for garbage and industrial wastes

We also have to eliminate the waste waters in the harbour basin where the evacuation water pipes are too long, outside the harbour, until 15-20 m for a greater efficiency.

In order to collect, neutralize and to make valid the wastes it is necessary to enclose the harbour on the land with special equipments. As solid wastes of Constantza and Constantza South harbours are very area and it is difficult for the towns to deposit these wastes, there have been built enclosures for them, together with earth-wich will constitute port territories, in connection with the further development of the port.

As for the connection of the salted water basin of the port to the Danube-Black Sea Canal, there have been provided solutions for the elimination of the salted water along the Canal. So, for Agigea lock there has been provided a system filling-emptying through which the salted water with a greater density is always kept at the lower part of the lock under the volume of the Canal (fig.3)

A special attention is given to the self-purification capacity of the sea, that is to decompose the polluting substances and to regime the natural characteristics of the clean water this process is most active when the quantity of oxygen is greater.

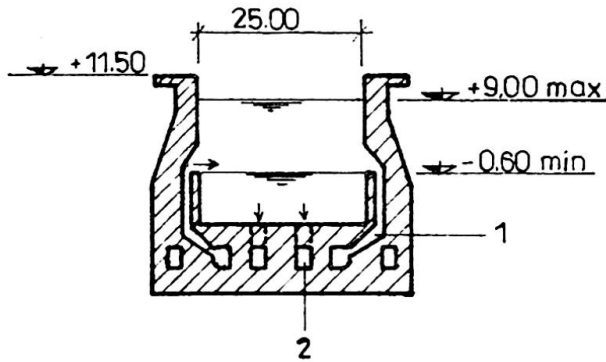

Fig.3-Lock of Danube-Black Sea Canal
1-gallery of sweet water; 2-gallery of salty water

That is why achieving bioactive works has an important role for the biological productivity and for raising the role of biochemistry and water oxygening.

In these sense there have made breakwaters for shore protection with bioactive role of type of artificial recif, which should made a divers power of biofiltre.

These diques located at about 400 m from the shore at -5.00 m fathom line, are of 200-300 m long and made of hole blocks protected with stabilopods (fig.4)

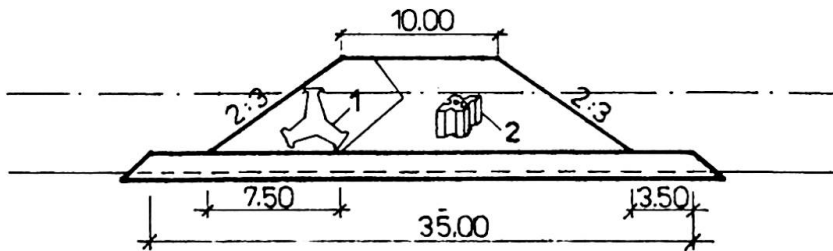

Fig.4 Breakwater-cross section
1-stabilopod 200 KN; 2-bioactiv block 150 KN

In order to increase such on artificial recif, there have been provided bioactiv blocks, wich should provide, favorable condition to the sea life. That may be done by practicing into the block bodies holes of 200-250 mm diametre wich should allow the water circulation (fig.5).

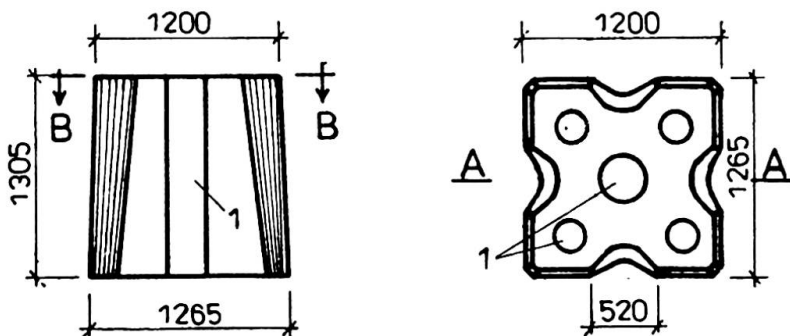

Fig.5 Concrete block (B=150 KN) acted biologically
1-cylindric emptys



To a block of 15 t we may obtain a growth of about 8 sq.m. that is 40%. The increasing of efficiency of these artificial reefs is obtained without supplementary investments.

* *
*

The achievements of the above objectives imply important material and financial resources but must take into account the ecologic keeping and the environment protection, ecology becoming the first step.