

**Zeitschrift:** IABSE congress report = Rapport du congrès AIPC = IVBH  
Kongressbericht

**Band:** 14 (1992)

**Artikel:** Design and construction of green Dome Maebashi

**Autor:** Tominaga, Hiroh / Saitoh, Masao / Nakajima, Hajime

**DOI:** <https://doi.org/10.5169/seals-13806>

### **Nutzungsbedingungen**

Die ETH-Bibliothek ist die Anbieterin der digitalisierten Zeitschriften. Sie besitzt keine Urheberrechte an den Zeitschriften und ist nicht verantwortlich für deren Inhalte. Die Rechte liegen in der Regel bei den Herausgebern beziehungsweise den externen Rechteinhabern. [Siehe Rechtliche Hinweise.](#)

### **Conditions d'utilisation**

L'ETH Library est le fournisseur des revues numérisées. Elle ne détient aucun droit d'auteur sur les revues et n'est pas responsable de leur contenu. En règle générale, les droits sont détenus par les éditeurs ou les détenteurs de droits externes. [Voir Informations légales.](#)

### **Terms of use**

The ETH Library is the provider of the digitised journals. It does not own any copyrights to the journals and is not responsible for their content. The rights usually lie with the publishers or the external rights holders. [See Legal notice.](#)

**Download PDF:** 08.02.2025

**ETH-Bibliothek Zürich, E-Periodica, <https://www.e-periodica.ch>**

## Design and Construction of Green Dome Maebashi

Conception et construction du stade "Green Dome Maebashi"

Planung und Konstruktion des Green Dome Maebashi — Stadions



**Hiroh TOMINAGA**  
Manager  
Shimizu Corp.  
Tokyo, Japan

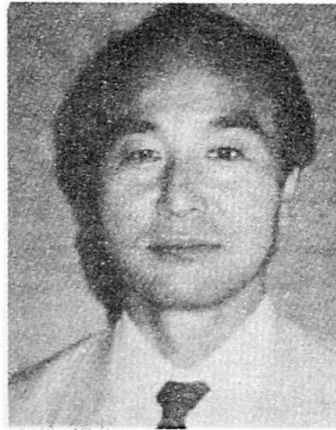

**Masao SAITOH**  
Prof. Dr.  
Nihon Univ.  
Tokyo, Japan



**Hajime NAKAJIMA**  
Structural Eng.  
Shimizu Corp.  
Tokyo, Japan



**Tshiyuki YAMADA**  
Deputy Manager  
Shimizu Corp.  
Tokyo, Japan

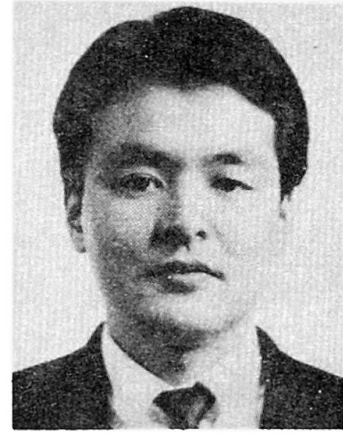

**Takayuki NISHIYA**  
Structural Eng.  
Shimizu Corp.  
Tokyo, Japan

### SUMMARY

This paper describes structural design and construction practice of the Dome. In the design, computer simulation was conducted to study the method and procedure of construction. During its construction, stresses and deformations of the roof structure were measured.

### RÉSUMÉ

Cette communication décrit la conception structurale et les travaux de construction de la coupole. La simulation sur ordinateur a été exécutée en vue d'étudier la méthode et les étapes de construction. Pendant la mise en œuvre, les contraintes et déformations de la couverture ont été mesurées sur place.

### ZUSAMMENFASSUNG

Diese Abhandlung beschreibt den Entwurf und die Konstruktion des Stadion. Die Bauverfahren wurden während der Entwurfsphase anhand von Computer-Simulation untersucht. Die Beanspruchungen und Verformungen, die auf die Dachstruktur wirken, wurden während des Bauvorgangs vor Ort gemessen.



1. INTRODUCTION

The roof of Green Dome Maebashi has an oval type of Beam String Structure (BSS) in which the parallel type of BSS and the radial type of BSS are connected to the rigid center ring girder. This shallow domed roof, in addition, has concentric half circles of arched sub beams and horizontal braces for ensuring its stretching rigidity.

The structural design of the roof is based on the principle that the dead load should be carried by the main members of the roof while the load due to earthquake, wind, snow and temperature are handled by the secondary members such as sub beams and braces as well as the main members. During construction, when cables are prestressed after the completion of the erection of roof steel, stress will act in all beams, sub beams and braces because of the effect of dome action. For this reason, as study of the planning of steel work and finish work, the computer simulation of the processes of the construction was done in order to establish good methods and procedures for erection of steel and for prestressing. After the construction commenced, the stresses and the deformations of beams were measured to investigate whether or not the behavior of the huge roof during the construction works agrees with the data resulting from the above analysis. This paper describes such structural design, planning of construction work and the behavior of the roof structure during construction.

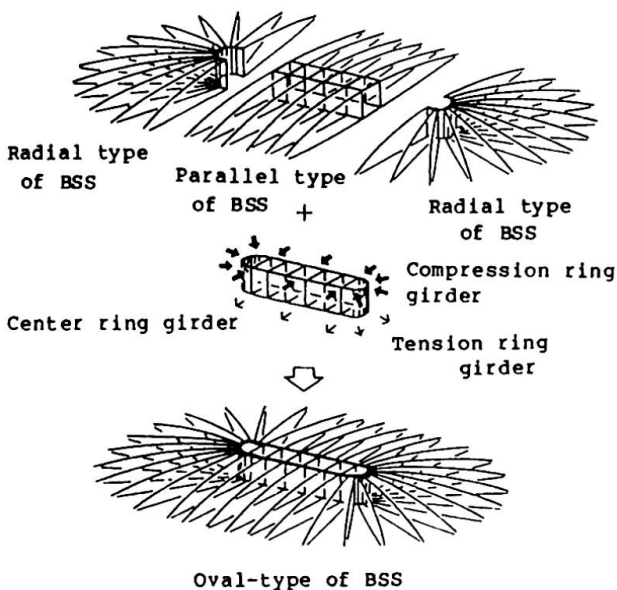
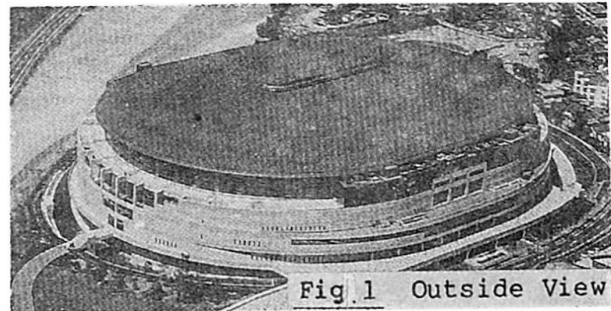
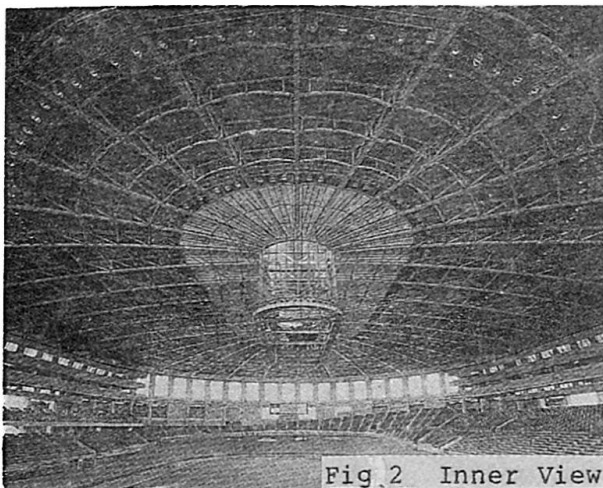

Fig. 3 Structural System

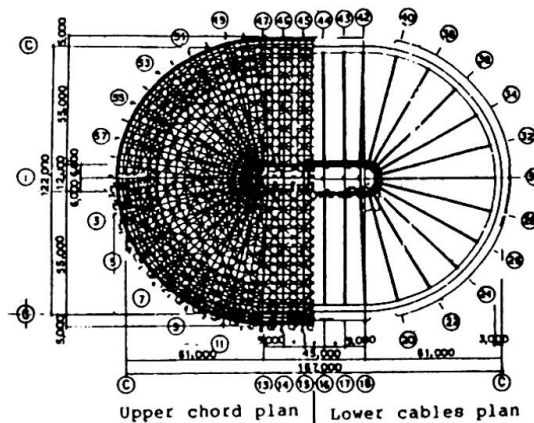

Fig. 4 Roof Framing Plan

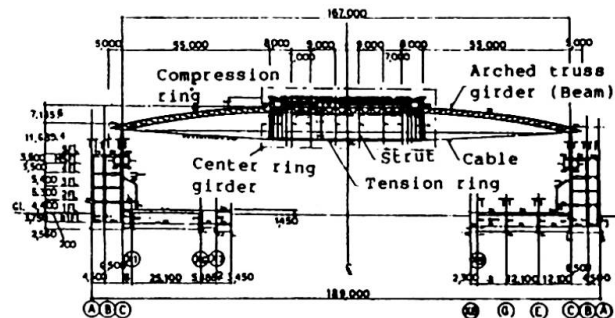

Fig. 5 Longitudinal Section



## 2. OUTLINE OF THE BUILDING

This building is composed of the huge roof with the oval-type Beam String Structure (167 m by 122 m) and the 6 layers stand with the steel-framed reinforced concrete structure which supports the roof. The roof area is approximately 20,000 m<sup>2</sup>, and the use of BSS realized the shallow oval dome with 0.057 rise/span ratio. One of the mechanical characteristic of BSS is the no existence of the horizontal thrust due to the dead load of the roof. Therefore, the roof structure can be supported simply by peripheral structure with large opening formed under the eaves.

The oval-shaped roof is composed of the parallel type of BSS and the radial type of BSS. These are connected by rigid center ring girders. Each BSS is composed of a beam, strut and cables. The beam is a 2.5 m deep arched parallel truss with H shape steel (series 400), the strut is a steel pipe (267 in diameter) and the cables are two spiral ropes (84 in diameter for parallel part and 74 in diameter for radial part). The roof is finished by the copper roofing with autoclaved light weight concrete (ALC) panel. The dead load specified by the design of the roof is 2400 N/m<sup>2</sup> as the uniform load.

## 3. STRUCTURAL DESIGN

A mechanical characteristic of BSS is the control of the stress distribution and deformation of beams by tensioning the cables. Therefore, the most important points of the structural design for BSS are specifying the shape of BSS and the optimum prestressing force for their cables.

## 4. PRELIMINARY EXAMINATION OF CONSTRUCTION WORK

Prior to the construction work of BSS, it is necessary to make examinations for deciding how much tension should be applied, when the tension application should be carried out and how it will affect the entire schedule of construction works. The examinations was proceeded using a computer simulation of the construction procedure. The basic data for planning the construction work, especially the procedures for the election of steel was proposed. From now on, the optimum prestressing force and the relation between construction procedure and prestressing force will be described.

### 4.1 Calculation of Optimum Prestressing Force

The load which affects the building most is considered to be its dead load. Therefore, at first the optimum prestressing force was specified realizing the minimum deflection and stress of beams.

The deformation and the stress of point, are defined by the following equations:

$$\delta_i = \alpha_{iw} \cdot W + \alpha_{iA} \cdot T_A + \alpha_{iB} \cdot T_B \quad (i=1,2) \quad (1)$$

$$S_i = \beta_{iw} \cdot W + \beta_{iA} \cdot T_A + \beta_{iB} \cdot T_B \quad (i=1\sim 4) \quad (2)$$

where, W is dead load, T is tensile force of cables (T<sub>A</sub>: for Parallel part, T<sub>B</sub>: for Radial part), and  $\alpha$ ,  $\beta$  are influent factors for their loads. Considering the deformation of the center ring girders and the stress distribution in the beams, the optimum prestressing forces are obtained in the case of the presence of secondary members and in that of the absence of secondary members, as shown in Table 1.

### 4.2 Procedure of BSS Construction

For the construction work of BSS requiring the application of prestressing force, it is necessary to examine such points as:

(1) the time for prestressing, (2) the level of the load for applied prestressing force, (3) the number of jacks and the capacity of each jack for



prestressing, (4) the influence of the restriction of the secondary members and (5) the rigidity of temporary supports. The proposed procedure of the construction work of BSS will be process a and b shown in Fig.7.

In process a, the cables are prestressed after the completion of steel work and finish work. In process b, the cables are prestressed just after the election of steel, and then additional tension force is applied to them by finishing weight.

4.3 Computer Simulation for the Procedure of the Construction Work

The numerical analysis was executed by using five analysis cases whose parameters are a construction procedure, the restriction of secondary members and an optimum prestressing force (Table 2). The result of the simulation for the final stage of construction work is shown in Fig. 8. The deformation, the stress in the beams, the axial force in the sub beams and the axial force in the braces in case d match the result of the simulation in case b2.

The only disadvantage in case b1 is the restriction of the secondary members due to the large deformation of the roof. This disadvantage can be eliminated by adopting the roof construction procedure including the slit zone system (case b2), and thus it is possible to ensure the quality specified by the design.

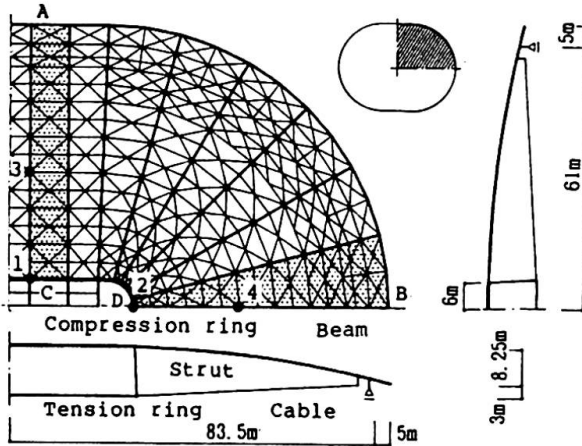

Fig. 6 Analysis Model

Table 1 Optimum Prestressing Force With and Without Secondary Members (kN)

	With Secondary Members	Without Secondary Members
$\delta_1 = \delta_2 = 0$ Equation (1)	$T_A = 3773,$ $T_B = 2372$	$T_A = 3989,$ $T_B = 2940$
$S_1 = S_3,$ $S_2 = S_4$ Equation (2)	$T_A = 3773,$ $T_B = 2391$	$T_A = 3871,$ $T_B = 3273$

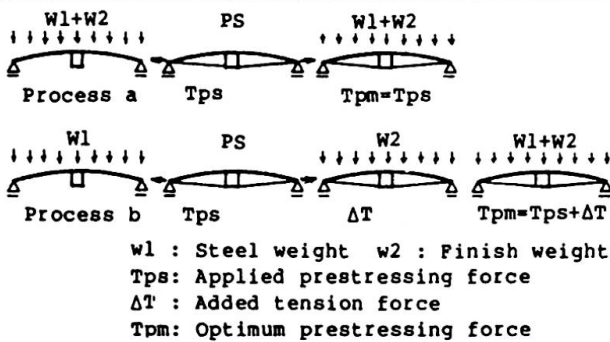

Fig. 7 Construction Process

Table 2 Analysis Cases

	d	a1	a2	b1	b2
Construction Process	-	a	a	b	b
Secondary Members	NO	YES	YES	YES	YES*
Tpm (kN)					
Parallel	3773	3920	NON*	3773	3773
Radial	2401	3087		2401	2401

YES\*: According to the construction procedure including the slit zone system.

NON\*: Dome structure without cable.

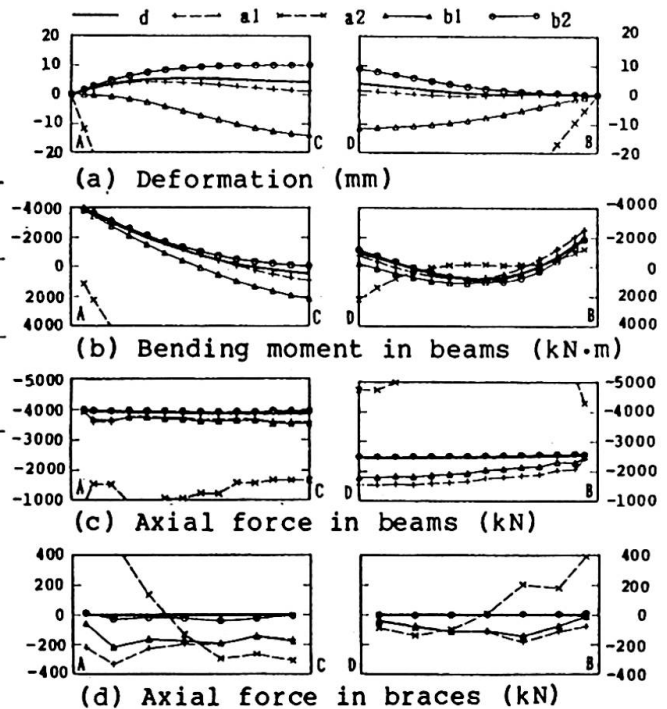

Fig. 8 Result of Simulation for the Final Stage of Construction Work (completion)



## 5. CONSTRUCTION PLAN

As for construction of roof steel, the center ring girders are placed on temporary supports, and the truss beam is assembled on the ground and then lifted up. Fastening of 68 cables goes in parallel with the erection of roof steel, and the fastened cables are prestressed just after the completion of roof steel erection.

### 5.1 Prestressing Force Application

Prestressing force is applied to the cables by using 68 center-hole hydraulic jacks to tension all the 68 cables simultaneously. To go into details, the application is conducted by 18 groups using automatic load control device. The load on the hydraulic jacks in the charge of each group is indicated in percentages by a digital load meter in the main control room, the specified prestressing force being as 100%. The specified prestressing force, which measured 1460 to 1480 kN for cables of a parallel part and 902 to 941 kN for cables of a radial part, is applied at steps.

### 5.2 Measurement under Construction

The loads, deformation and stresses were measured in the BSS in order to find out the behavior of the structure in the process of the construction. The measured result and the values resulting from the prediction by the analysis considering the construction procedure will be described from now.

The basic point (zero point) for load measurement by a load cell is that in which no load is applied to the structure, and the basic point (zero point) for deformation and strain measurement is that in which 20% of the total prestressing force is applied. Every application of prestressing force was followed by measurement and examination, which were repeated when necessary, as shown in Fig.9.

## 6. RESULT OF THE MEASUREMENT

### 6.1 Tension of cable

The relation between the processes of construction and tension of cable is shown in Table 3. When prestressing was completed, all the 18 digital load meters indicated 100%. At this time, the actual data obtained with the load cells agreed 99.5 to 103.1% with the data resulting from the analysis. In addition, the vibration method to measure the tension of all the 68 cables was used. Then, the tension was calibrated by using as a standard the actual data obtained with a load cell, and the tension of each cable was calculated. The result was that the errors range from 4.8 to 3.7%. The errors in the measured tension when the ALC application work was completed ranged from 0.7 to 6.7%, and those when the roof construction was completed from 3.6 to 0.6%, so the actual data agreed well with the data resulting from the prediction.

### 6.2 Tension of cable, deformation and stress

The vertical deformation of the compression ring increases greatly in harmony with its predicted values once the roof parts from the supports. Then, the deformation begins diminishing because the finish work increases the weight of the roof. The actual data results in good agreement with their predicted values throughout the processes of the roof construction (see Fig.10).

The axial forces in the centers of the beams increase monotonously in the course of the construction processes. Their actual data and predicted values agree well with each other. As for the bending moment, its actual data are smaller than its predicted values after prestressing, but they agree with each other when the roof construction was completed (see Fig.11).

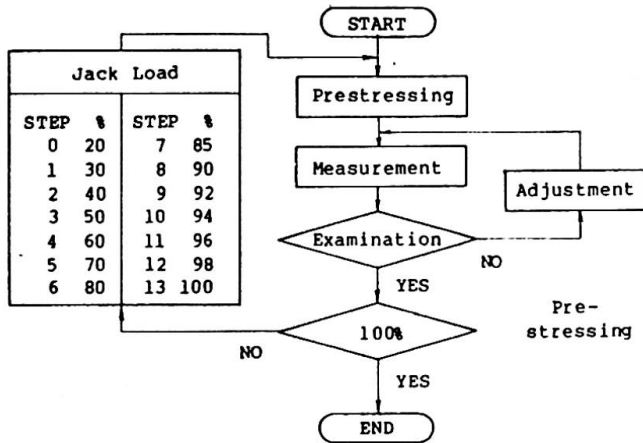

Fig.9 Flowchart of Prestressing and Measurement

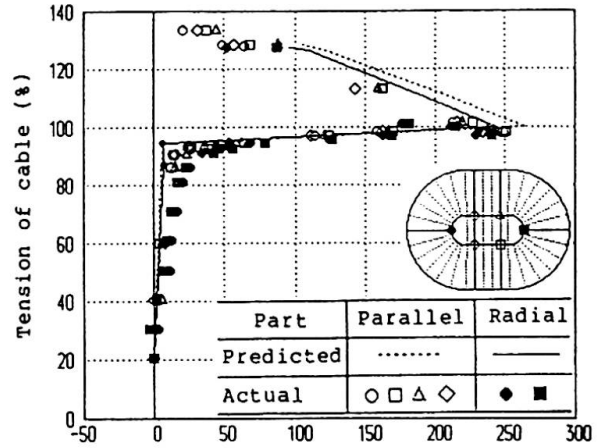

Fig.10 Relationship between Tension of Cable and Vertical Deformation of Cable and Vertical Deformation

Table 3 Construction Processes and Tension of Cables (kN per cable)

Construction Process		Location					
		1	7	11	13	14	46
After pre-stressing	Actual (by load cell)	951 936	954 959	921 917	1498 1484	1482 1512	1497 1480
	Actual (by vibration method)	1026 999	999 1026	972 972	1618 1579	1576 1616	1616 1616
	Predicted	941	931	902	1480	1470	1470
After ALC work	Actual (by load cell)	1201 1198	1232 1240	1242 1249	1948 1930	1949 1983	1968 1951
	Predicted	1189	1187	1181	1876	1844	1844
Completion	Actual (by load cell)	1160 1157	1189 1195	1189 1195	1872 1851	1862 1897	1882 1897
	Predicted	1201	1201	1201	1887	1887	1887

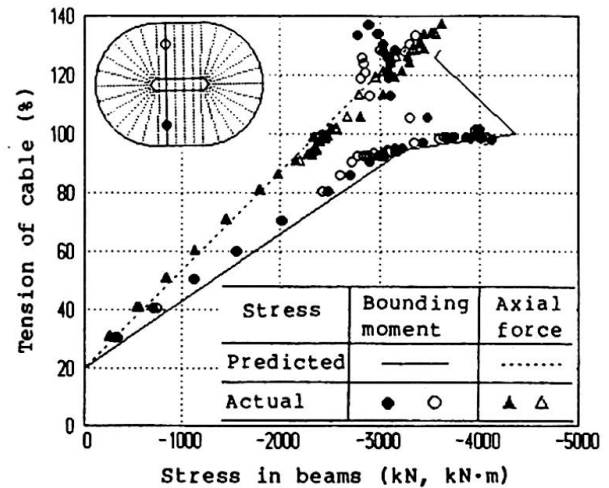

Fig.11 Relationship between Tension of Cable and Stress in Beams

7. CONCLUSION

The design and construction of Green Dome Maebashi has been described so far. The description will confirm the following points:

- (1) The actual data on such points as deformation and stress agreed well with their predicted values.
- (2) Simultaneous prestressing proved to be reliable and effective.
- (3) As it had been expected, the additional tension of the cables acted as finish work advanced. And the ultimate tension agreed well with the specified value (optimum tension).
- (4) The roof construction procedure including the slit zone system proved to be effective for the countermeasure of the restriction of secondary members during prestressing and finish work.

From the above, it may be concluded that the method of prediction and the construction work of prestressing are worthwhile.

REFERENCE

Saitoh, M., "Beam String Structures", 1989 Madrid IASS Congress  
 Tominaga, H., "Design and Construction of Green Dome Maebashi", 1991 Copenhagen IASS Symposium