

Zeitschrift: IABSE structures = Constructions AIPC = IVBH Bauwerke
Band: 2 (1978)
Heft: C-3: Recent structures

Artikel: Zarate-Brazo Largo Highway-Railway System (Argentina)
Autor: Grünbaum, Carlos
DOI: <https://doi.org/10.5169/seals-15089>

Nutzungsbedingungen

Die ETH-Bibliothek ist die Anbieterin der digitalisierten Zeitschriften. Sie besitzt keine Urheberrechte an den Zeitschriften und ist nicht verantwortlich für deren Inhalte. Die Rechte liegen in der Regel bei den Herausgebern beziehungsweise den externen Rechteinhabern. [Siehe Rechtliche Hinweise.](#)

Conditions d'utilisation

L'ETH Library est le fournisseur des revues numérisées. Elle ne détient aucun droit d'auteur sur les revues et n'est pas responsable de leur contenu. En règle générale, les droits sont détenus par les éditeurs ou les détenteurs de droits externes. [Voir Informations légales.](#)

Terms of use

The ETH Library is the provider of the digitised journals. It does not own any copyrights to the journals and is not responsible for their content. The rights usually lie with the publishers or the external rights holders. [See Legal notice.](#)

Download PDF: 08.02.2025

ETH-Bibliothek Zürich, E-Periodica, <https://www.e-periodica.ch>



7. Zarate—Brazo Largo Highway—Railway System (Argentina)

Owner: Ministry of Economy of the Argentine Republic,
National Highway Authority

Designer: TECHINT S.A., Buenos Aires, Argentina and
Ricardo Morandi, Rome, Italy

Consultants: Leonhardt und Andrä, Stuttgart, GFR
Fabrizio de Miranda, Milano, Italy
Imp. Ing. Lodigiani SpA, Milan, Italy
Dr. Ing. Josef Eisenmann, München, GFR

Contractor: TECHINT ALBANO S.C., Buenos Aires,
Argentina

Tests: ISMES, Bergamo, Italy
Atkins, Natl. Physical Lab., London, U.K.
Inst. für Modellstatik, Stuttgart, GFR

Dimensions and arrangement:

Highway:

2 double lanes, each 7.50 m wide
1 central shoulder 0.50 m wide

Railway:

Single track 4.50 m, Gauge 1.435 m

Bridges:

Total length, each: 550 m
Central span: 330 m, Lateral spans: 110 m
Height above water: 50 m

Width of steel superstructure: 22.60 m

Viaducts:

Length of highway approaches: 6.5 km
Length of railway approaches: 10.0 km
Distance between columns: 65 m
Length of each cantilever: 20 m
Length of each prestressed concrete beam: 45 m

Material used:

Volume of soil moved: 1.4 million cu m
Volume of concrete: 500'000 cu m
Reinforcing and prestressing steel: 50'000 tons
Number of railway prestressed concrete beams: 360
Weight: 220 tons each
Number of highway prestressed concrete beams: 600
Weight: 110 tons each
Weight of steel structure: 10'600 tons
Weight of suspension cables: 1'300 tons

General data:

Tender date: December 1970
Contract signature: April 1971
Commencement of work: November 1971
Completion of First bridge: February 1977
Completion of Second bridge: November 1977
In-service date of System: 1978
Contract value: US \$ 250 millions
Value of construction equipment: US \$ 30 millions
Work force: Maximum 2500 workmen

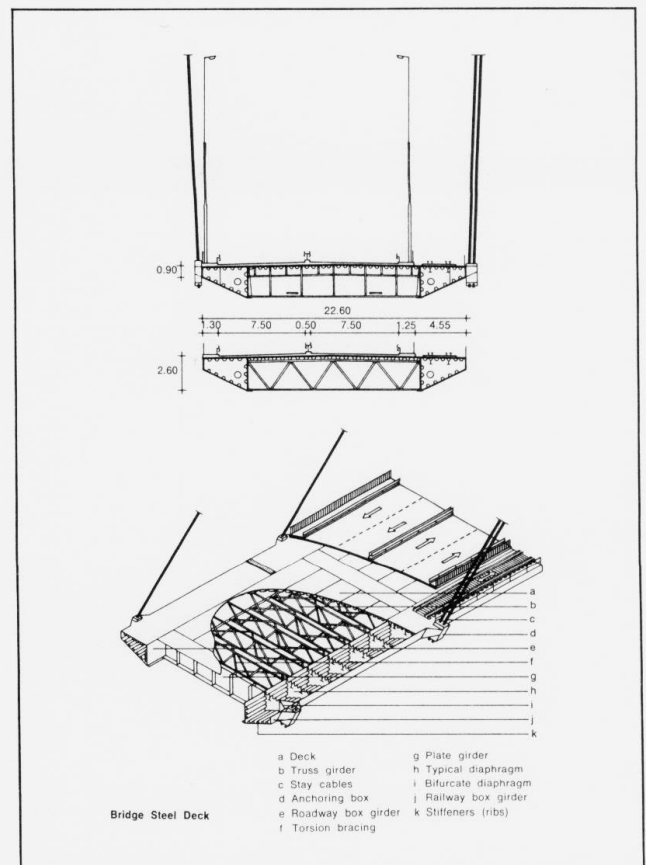
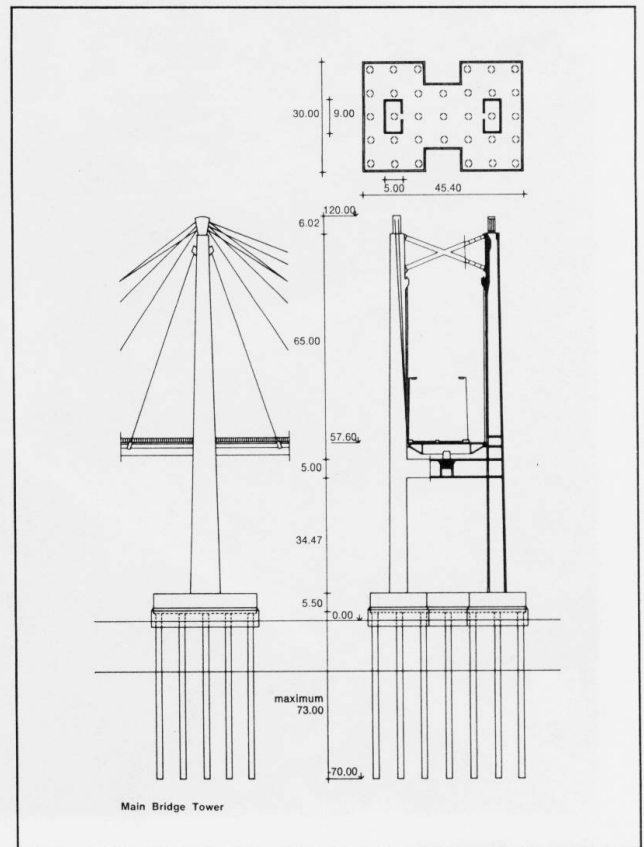

Description

The Zárate-Brazo Largo System of bridges will provide both road and rail links across the Paraná River between the Entre Ríos and Buenos Aires provinces only 80 km from Buenos Aires City.

The system consists of two bridges across the two arms of the Paraná River (Paraná de las Palmas and Paraná Guazú), each bridge carrying a four lane highway and one railway line. The two bridges are 30 km apart.

Technical Data

Each bridge has a total length of 550 m, with one central span of 330 m and two lateral spans 110 m each; total height above water 50 m, to allow navigation of large tonnage ships.

Each bridge is internationally unique by reason of having a suspension system-stay cables consisting of 144 HiAm-cables with max. 337 wires diameter 7 mm-supporting a railway and dual carriage road. The material used in the steel structure is RR ST 52.3 DIN 17100 steel and with special through-thickness requirements for some critical parts. The main towers are 120 m high above river level and are of variable rectangular hollow section and built using sliding forms. They are composed of two columns linked together by a reinforced concrete girder at deck level and a steel cross at the top. Each tower rests on a 8000 cu m reinforced concrete pile cap which in turn is supported by steel-cased reinforced concrete piles, 2 m in diameter; the depth of these piles reaches a maximum of 73 m.

The steel structure of the bridges is formed by:

- continuous longitudinal members of trapezoidal form box sections,
- main transversal members with a plate girder to fit with the lower anchoring points of cables,
- secondary transversal trusses and main orthotropic deck
- truss torsion bracing at the lower level.

Joining of the steel superstructure to the reinforced concrete needed special techniques:

a) For towers:

A tower saddle weighing 70 tons was fixed to the top of each column of both towers to serve as the main anchor to the converging cables. Between the bridge deck and the reinforced concrete girder of each tower, there are hydraulic dampers allowing longitudinal movement, which operate as sliding bearings for slowly-applied loads and as fixed bearings for fastly-applied loads. At the same level there are also sliding compressible bearings controlling transversal movements without restricting longitudinal movements.

b) For anchorage piers:

The bridge superstructure is connected to the anchorage piers by vertical steel rods which allow it to rotate and move longitudinally. These are complemented by bearings which control transverse movement.

Using special equipment, the bridge deck and superstructure were cantilevered out from both towers. Long approach viaducts to the bridges were required because of their great height above the river. The approach viaducts consists of columns spaced 65 m apart, of square hollow section erected on piled foundations. The top of each column has cantilever supports on which the 45 m prestressed beams carrying the road and railway merely rest. Special launching equipment was used to transport and erect them.

(Carlos Grünbaum)

