

Zeitschrift: IABSE structures = Constructions AIPC = IVBH Bauwerke
Band: 5 (1981)
Heft: C-18: Structures in the Middle East

Artikel: The Fourth Mosul Bridge and approaches (Iraq)
Autor: Vesely, V.
DOI: <https://doi.org/10.5169/seals-16987>

Nutzungsbedingungen

Die ETH-Bibliothek ist die Anbieterin der digitalisierten Zeitschriften. Sie besitzt keine Urheberrechte an den Zeitschriften und ist nicht verantwortlich für deren Inhalte. Die Rechte liegen in der Regel bei den Herausgebern beziehungsweise den externen Rechteinhabern. [Siehe Rechtliche Hinweise.](#)

Conditions d'utilisation

L'ETH Library est le fournisseur des revues numérisées. Elle ne détient aucun droit d'auteur sur les revues et n'est pas responsable de leur contenu. En règle générale, les droits sont détenus par les éditeurs ou les détenteurs de droits externes. [Voir Informations légales.](#)

Terms of use

The ETH Library is the provider of the digitised journals. It does not own any copyrights to the journals and is not responsible for their content. The rights usually lie with the publishers or the external rights holders. [See Legal notice.](#)

Download PDF: 06.05.2025

ETH-Bibliothek Zürich, E-Periodica, <https://www.e-periodica.ch>



8. The Fourth Mosul Bridge and Approaches (Iraq)

Owner: State Organization of Roads and Bridges
Baghdad, Iraq

Engineer: Pragoprojekt, Prague, CSSR.

General

Mosul is a significant center in the northern part of Iraq. It lies on the Tigris River which is crossed at present by three bridges inside the town. The last arch bridge was constructed by a Chinese contractor and was finished two years ago. Due to the expanding development of the town and its suburbs, a master plan has recently been worked out. According to this plan, Mosul should have, in the future, a total of seven long bridges across the Tigris River which will become the key to the further development of traffic in this area.

Since 1978 a team of Czechoslovak experts for bridge design and construction has been working at SORB in Baghdad. This team was charged with the drawing up of proposals for the new Fourth Mosul Bridge including approaches and access roads.

Situation

The Tigris River at the proposed bridge site is characterized by a wide, flat channel edged with earth dams on both banks. The whole channel is about 500 m wide but is full of water only in the spring season. The difference between high and low water levels is nearly seven meters. As a structure was required which would allow ships to pass under the bridge in future, navigation passage in minimum dimensions of 30 m x 6.25 m

had to be considered. The bridge has been designed to carry six lanes of traffic and two footpaths. The total width equals 31 m and the angle of crossing is 63°.

Solution

Superstructure

In the preliminary project, three variants of the bridge were taken into consideration.

In the first, a composite structure was designed, using U-shaped precast prestressed beams 44 m long and 2.4 m deep with cast in situ reinforced concrete deck-slab. This dual carriageway bridge has 15 spans and measures 660 m in total length.

In the second variant, a superstructure was designed to be built by the incremental method of construction. The bridge has two separate box girders with side cantilevers, one beneath each carriageway. The manufacturing plant would be on the right bank of the Tigris, and the girders would be shifted across the auxiliary supports. The bridge is of constant span length of 56 m except for the first spans of 44 m. The total length of the bridge equals 648 m.

In the third variant, a cable-stayed bridge was designed for the main part of the crossing on the right side of the channel in combination with a composite structure along the lines of the first version for the remaining «flooding» part of the channel.

The superstructure is formed by only one five-box girder with side cantilevers and is cable-stayed with five cables located in the centre line of the bridge. The cables are anchored within the right bank abutment of massive concrete construction. One inclined tower of

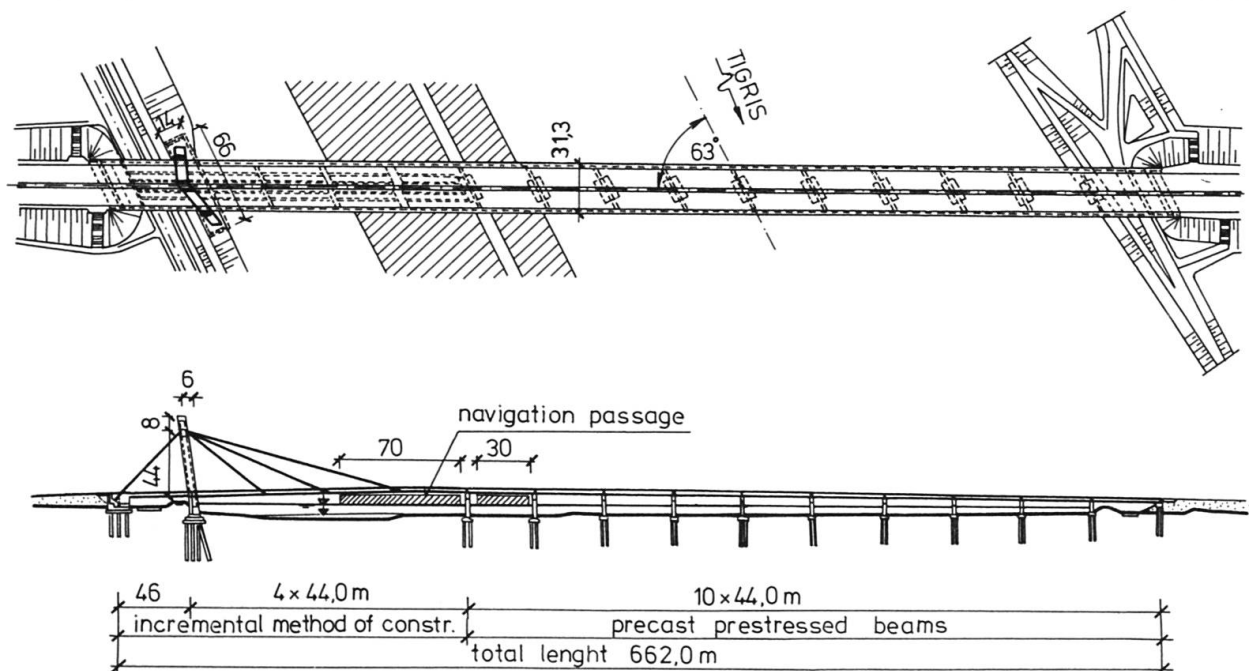

Fig. 1 General arrangement, Variant C

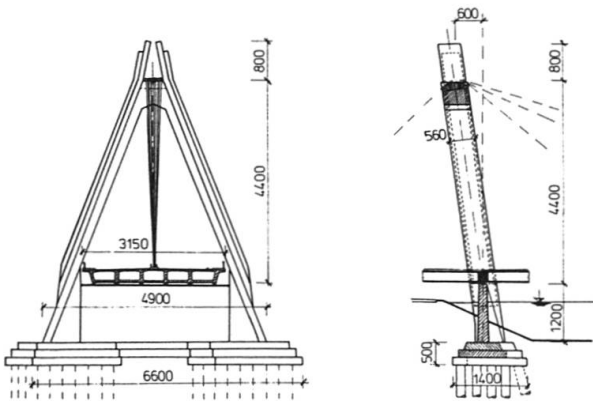

Fig. 2 Tower of cable-stayed bridge

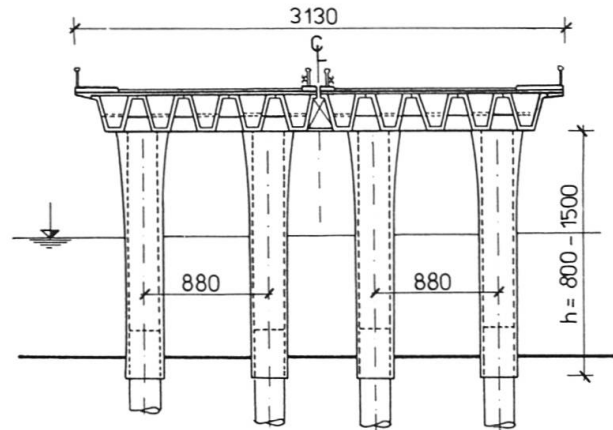

Fig. 4 Column pier for 1st variant

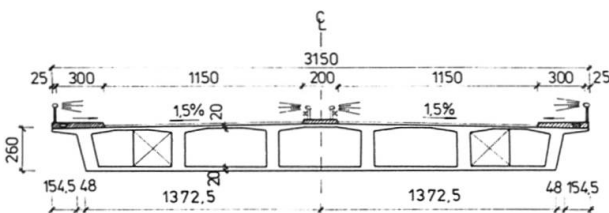

Fig. 3 Cross section of cable-stayed bridge

about 64 m height is of solid reinforced concrete built with a steel form. It has been located on the right bank of the river to form an architectonic counterpart to the nearby hill, Nabi Yunis, on the opposite bank. The cable-stayed structure was designed to be constructed by the incremental method and shifted gradually across the channel from the right embankment. Auxiliary supports are to be installed before activating the cables. The shifting of the superstructure is accomplished by three separate box parts which are finally to be interconnected by cast in situ up and down deckslabs.

Substructure and foundation

For the precast prestressed beams variant, either prestressed concrete web piers or column piers, columns of which are to be interconnected with a countersunk cross beam, were considered. For the variant using the incremental construction method, V-shaped piers of solid reinforced concrete were designed. In all three variants the foundation of piers and tower rest on bored piles of 1,800 mm diameter and 2,000 mm diameter respectively. Ultimate bearing capacity for one pile up to 20 m deep was calculated as 7,000 kN. Piles are to be transported by means of a steel jetty.

Conclusion

Bridges in Iraq across the main Tigris and Euphrates Rivers are characterized by great length, a very flat river channel and by the great difference between high and low water levels.

Also, scouring of the river bottom sometimes up to 5 m deep has to be taken into account. As there is almost no bedrock, only friction piles can be used for the foundation. Insulation is not required for the structures due to scarcity of rainfall in Iraq.

(V. Vesely)

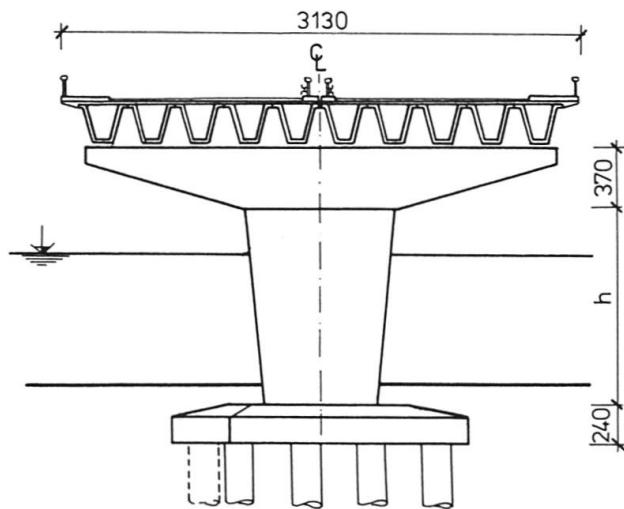

Fig. 5 Web pier for the 1st variant

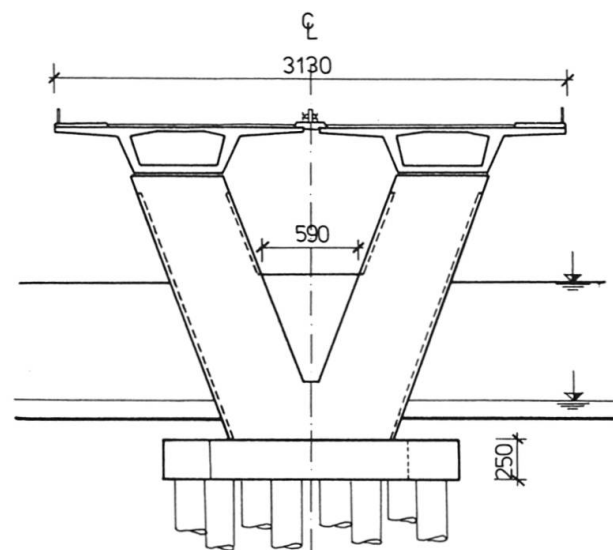

Fig. 6 V-shape pier for the 2nd variant