

Zeitschrift: IABSE structures = Constructions AIPC = IVBH Bauwerke
Band: 5 (1981)
Heft: C-19: Eastern Sheldt Strom Surge Barrier (the Netherlands)

Artikel: The pier design
Autor: Geest, J.M. van
DOI: <https://doi.org/10.5169/seals-16994>

Nutzungsbedingungen

Die ETH-Bibliothek ist die Anbieterin der digitalisierten Zeitschriften. Sie besitzt keine Urheberrechte an den Zeitschriften und ist nicht verantwortlich für deren Inhalte. Die Rechte liegen in der Regel bei den Herausgebern beziehungsweise den externen Rechteinhabern. [Siehe Rechtliche Hinweise.](#)

Conditions d'utilisation

L'ETH Library est le fournisseur des revues numérisées. Elle ne détient aucun droit d'auteur sur les revues et n'est pas responsable de leur contenu. En règle générale, les droits sont détenus par les éditeurs ou les détenteurs de droits externes. [Voir Informations légales.](#)

Terms of use

The ETH Library is the provider of the digitised journals. It does not own any copyrights to the journals and is not responsible for their content. The rights usually lie with the publishers or the external rights holders. [See Legal notice.](#)

Download PDF: 17.03.2025

ETH-Bibliothek Zürich, E-Periodica, <https://www.e-periodica.ch>

3. The pier design

The piers in the barrier have to perform various functions:

together with the top beam and the sill beam, they form a frame for the vertical gates. Furthermore, they act as part of the water-retaining structure as a whole, and have to be properly connected to the stone materials of the base on and in which they are seated. They also have to transmit to the subsoil loads which are exerted on the water-retaining surfaces of the barrier. Finally, they act as piers in the true sense of supports carrying the bridge over the top of the barrier.

The pier must cause the least possible obstruction to the flow of water when the gates are open and they must attract as little load as possible other than that which is directly due to their water-retaining function. In addition, they must be transportable and be relatively easy to produce in quantity.

Pier foot

Once it had been decided to construct the pier in one piece, three alternatives for the design of the pier foot were first considered. First, a solid foot appeared to be least labour-intensive to produce and therefore attractive. When it quickly became apparent, however, that its weight would be so great (about 25,000 tons) as to make transport almost impossible, no further details were worked out. An additional consideration was that it is very desirable to have a working space over the bottom slab from which to carry out the operations to fill the cavity under the slab with grouting. No such space would be available with a solid pier foot. A pier foot with vertical walls was next designed, covered by a horizontal slab. It appeared to offer the advantage of simplicity of construction because of the absence of sloping walls (Fig. 1).

However, it would have required about 30% more concrete than the design subsequently adopted, turning what initially seemed to be an advantage into a disadvantage in terms of cost and labour. The design therefore evolved into a pier foot with inclined walls – the most advantageous in respect of materials, labour and cost (Fig. 2).

From the technical point of view the closed box shape is attractive because it possesses high tensional rigidity and can therefore easily resist the torsional moments liable to be caused by the irregular bearing of the pier on the foundation bed. This design is also best suited to cope with the transmission of the forces from the gates and beams to the bottom slab. It was accordingly worked out in greater detail. In its initial form it had inclined end walls as well as inclined lateral walls but this was later modified for practical reasons. At a later stage it was also found that attachments would have to be fitted to the pier foot so that it could be transported. This too, required vertical end walls. In the further process of working out the design the guiding principle was to achieve rationalization and optimization, with particular attention to cost and labour intensiveness (Fig. 3).

With a view to facilitating production of the piers in quantity and in order to take into account the design features of the lifting vessel, the pier feet all have more or less the same external shape. The height of the foot is

determined by various considerations, for example it is financially advantageous to have the foundation level as high as possible. Against this, the stability of the piers makes it necessary to embed part of the foot – 8 to 12 m – in the base. The sill beam, the lower beam connecting two adjacent piers, has to be 8 m high to enable it to resist the loads acting on it. The gates move up and down in guideways which must not extend into the pier

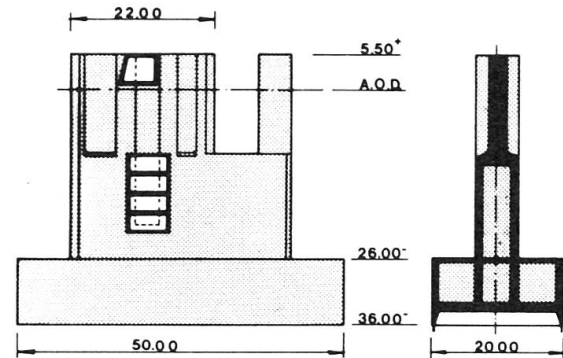

Fig. 1 Pier foot with vertical walls

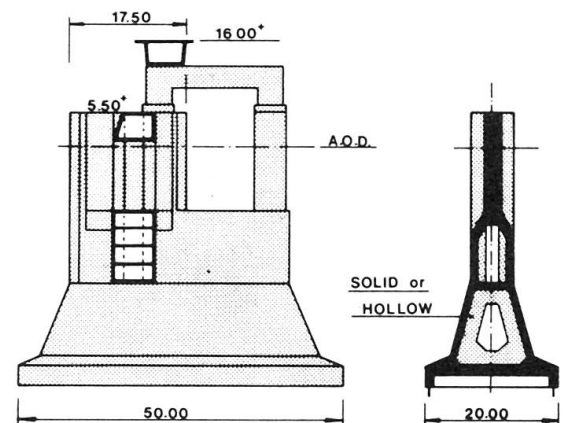

Fig. 2 Pier foot with sloping walls

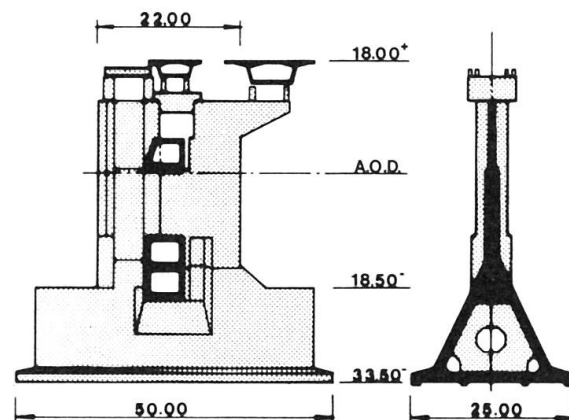

Fig. 3 Rationalization of the design with sloping walls

foot as they would weaken it excessively. From this it followed that the foot had to be 16 m high.

The recess into which the sill beam fits in the case of the piers with the highest foundation levels, that is embedded to the least depth in the base, must be accommodated within the pier foot, whereas in the piers with the lowest foundation levels (embedded 12 m) the sill beam recess is partly within the pier shaft.

An optimization study was carried out for four different bottom slab dimensions, namely, 20×50 m, 20×60 m, 25×50 m, and 25×60 m. Two main shapes for the pier foot were also studied: the first type comprised diaphragms (transverse internal partitions) in order to reduce the spans of the bottom slab and lateral walls of the foot; the second type had a prismatic cross-section with thicker walls and slab, but no diaphragms. In the solutions embodying a 20 m wide bottom slab the second type was preferred because the absence of diaphragms made the construction less labour-intensive. However, with a 25 m wide slab the second type necessitated an intermediate wall parallel to the lateral walls, extending longitudinally within the foot. This arrangement sacrificed much of the advantage offered by the prismatic cross-section. The study also showed that, taking a certain required bottom slab area as the starting point, a 25 m wide slab cost less per m² than a 20 m wide slab.

For structural reasons – susceptibility to transverse loading and to non-uniform bearing conditions – the first of the two above-mentioned types of pier foot was chosen, that is the one with diaphragms.

Spacing of the piers

The most desirable centre-to-centre spacing of the piers was found to be 45 m, with bottom slab dimensions of

25×50 m, embedding depths ranging from 8 to 12 m, and a sand fill in the foot of the final stage of completion. The foundation level varies from –21.5 m AOD for the piers with the least embedding, to –30 m AOD for those with the most (the latter being located in the middle of the Roompot, the deepest of the three flow channels). These conditions provided the starting points for the further design of the feet (Fig. 4).

Sill beams

The design of the sill beams also underwent a process of evolution which affected the shape of the recesses for them. The initial conception was to have a number of sill beams of various depths, stacked one on top of the other. By combining several beams, it would have been possible to obtain the desired overall depth in any particular opening between two piers. It was intended to construct beams 6 m wide. However, a closer study of the hydraulics revealed that, under certain extreme conditions during the closing of the gates or in the event of a gate jamming, there would be a risk of the sill beams being sucked upwards. At first it was supposed that they could be held in position by vertical struts, but this solution was found to be impracticable when the design was worked out further.

Instead, a trapezoidal-section sill beam was designed, whose upper surface was only 5 m wide, thus substantially reducing the total suction force to which it would be subjected. Its inclined seaward face is subject to vertical load which is due to the pressure from the water in the North Sea and which is beneficial to its stability. The inclined face also reduces the pressure exerted on the beam by the base. Structurally the sill beam has to be 8 m in depth (its vertical dimension) in a single monolithic whole and 8 m at its undersurface. The more elaborate design, as compared with the initial concep-

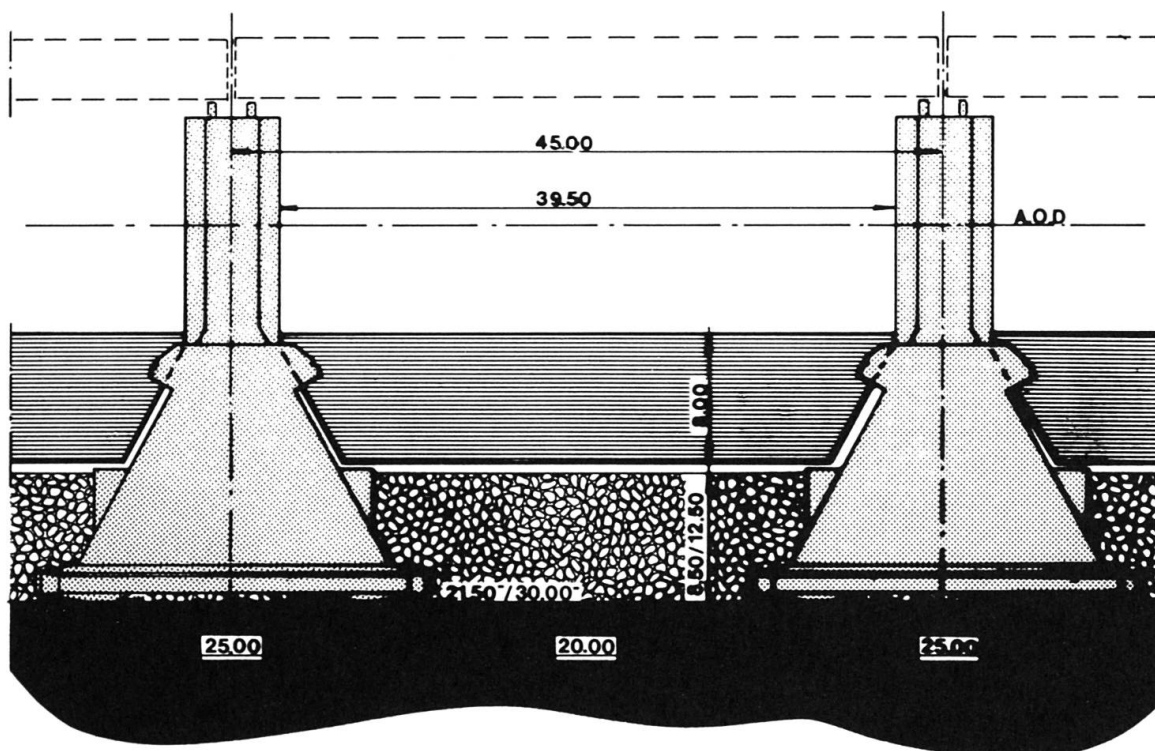

Fig. 4 Pier feet installed on the bottom

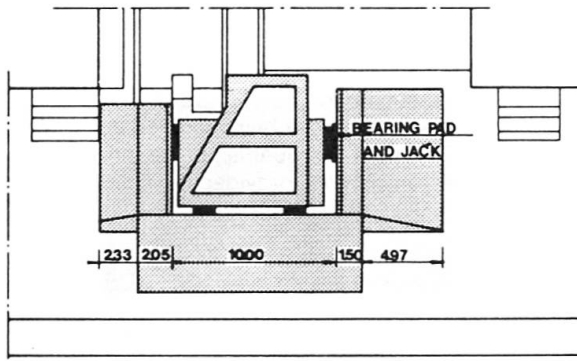

Fig. 5 Sill beam

tion of a rectangular cross-sectional shape, made it particularly desirable to achieve uniformity in these beams for all the openings in the storm surge barrier (Fig. 5).

When installed in the completed structure, the sill beam will have some freedom of movement in relation to the piers, as a result of the insertion of thick rubber pads between beam and pier.

Lifting frame

To enable the piers to be lifted and handled by the lifting vessel, suitable attachments for gripping them are necessary. During transport the pier foot will be immersed to a depth of 11 m and filled with air, that it develops its own buoyancy of 9,000 tons. As the dead weight of a pier is 18,500 tons, a load of 9,500 tons remains to be lifted. To allow for dynamic effects, this load has to be multiplied by a factor of 1.2.

A number of possibilities for transmitting this lifting force from the lifting vessel to the pier were investigated. One proposal was to secure a lifting frame to the upper part of the pier shaft, while the pier itself would have to be sufficiently prestressed to enable the force to be transmitted from the shaft to the foot. On the other hand, if the lifting force is applied low down no extra prestressing of the shaft is necessary. This latter alternative was found to be less expensive and also more favourable with regard to the design of the lifting vessel. With this method the points of attachment on the pier are situated further apart.

There were various possible ways of fixing the lifting frame to the pier foot: by means of prestressing tendons, with «hammerhead» bolts, or with lifting claws engaging with projections formed on the foot (Fig. 6).

The handling system is to be automated, so that the only manual intervention will be by the operator at the control panel. The last-mentioned method of securing the lifting frame was chosen.

Pier shaft and superstructure

In the early stages of the barriers' design the intention was to provide double sets of gates with a back-up system as a safety precaution in the event of gate failure. But a second gate would not in fact enhance the safety of the system for it was found that if the seaward gate failed to operate and the rear was closed, the longitudinal and transverse loads on the piers would increase so as to endanger their stability. It was also shown that

even if one gate in the barrier failed to close, the level of the water in the Eastern Scheldt would not become unacceptably high. It was therefore decided to dispense with the back-up system of gates. This design also enabled relatively simple arrangements to enable an additional box girder to be installed on a series of secondary piers mounted on the pier foot at a later stage, should an extension of the road capacity then be required (Fig. 7).

The cavity within the box girder over the top of the barrier is to be utilized to accommodate various installations and services for the gate operating machinery. This means that the girder must already be in position when the gates are positioned. The upper beam and sill beam of the gate opening will be installed later. To enable the upper beam to be lowered vertically into position, the cantilever slab of the box girder will be completed only after the beam has been installed.

The level at which the box girder has to be mounted on the structure is governed by the requirement that the road on the girder must be clear of any water washing over the structure. At first it was considered that the underside of the girder would therefore have to be

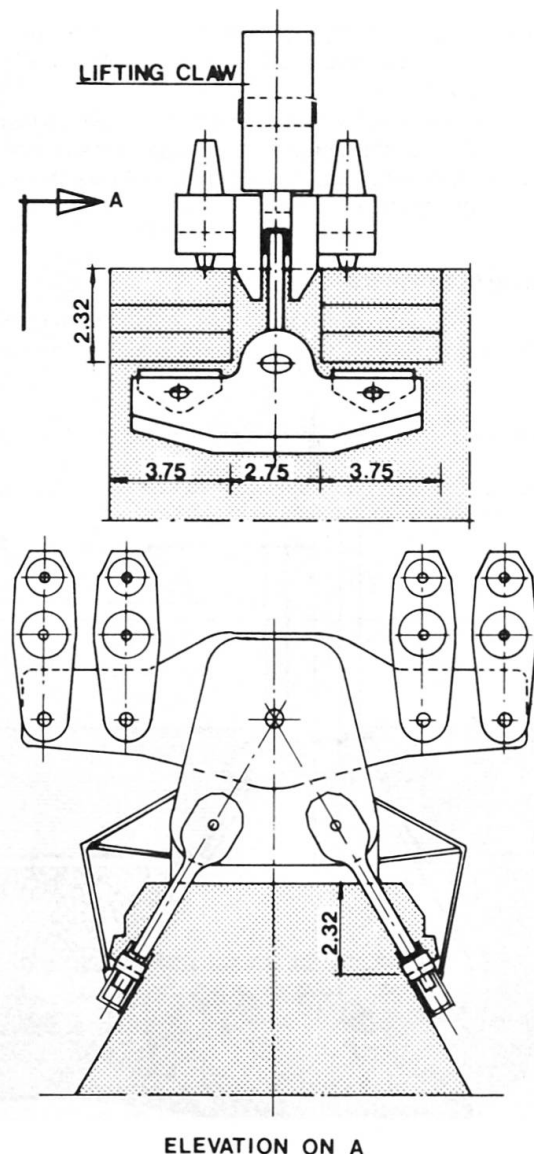

Fig. 6 Lifting attachments secured to pier foot

placed at + 14 m AOD and that the bridge deck would thus have to be at + 18 m AOD. However, a further investigation showed that there would be sufficient safety against overtopping waves if the underside of the girder was at + 8 m AOD and its upper surface (the bridge deck) at + 12 m AOD.

It was found necessary to extend the guideways for the gates to + 9.25 m AOD. The upper beam is mounted in a recess in the pier shaft, so that its underside is located at + 1.00 m AOD. To accommodate the lifting steel frame to move the gates the piers will subsequently be

extended upwards to max. + 21.65 m AOD by the addition of precast concrete units. The cross-section of the pier shaft is determined by structural requirements and a number of functional ones. To accommodate the gate guideways, the shaft has to be 5.50 m wide. For accessibility of the chamber within the pier foot there have to be two vertical passages occupying a width of 3.50 m. The recesses for accommodating the bearings of the upper beam and sill beam necessitate a greater width of the pier shaft, and for structural reasons this width has been continued rearward.

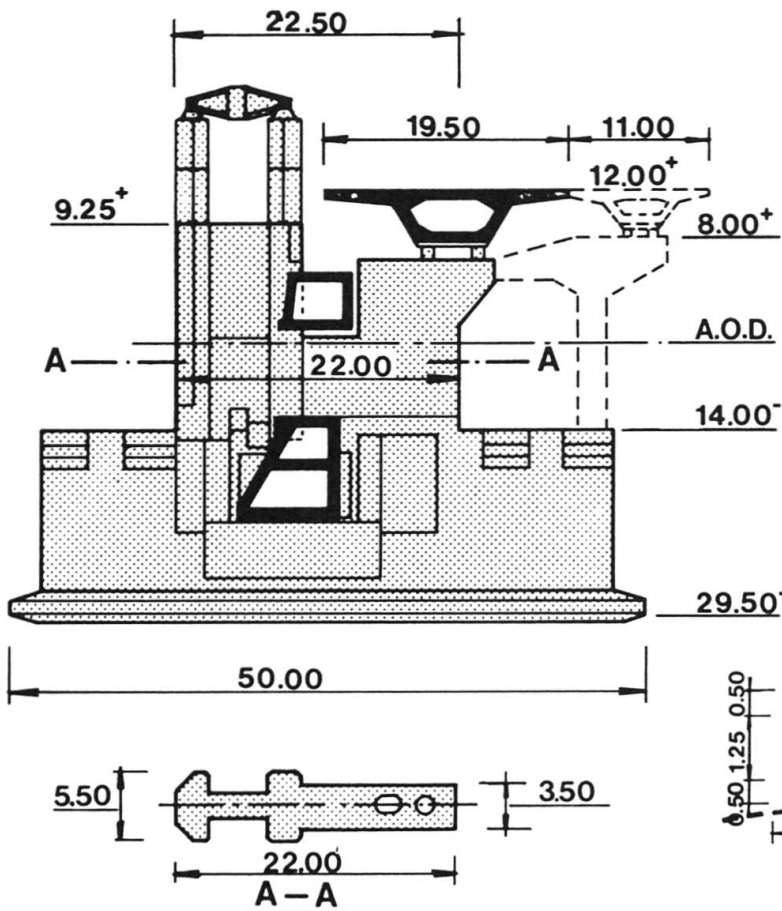

Fig. 7

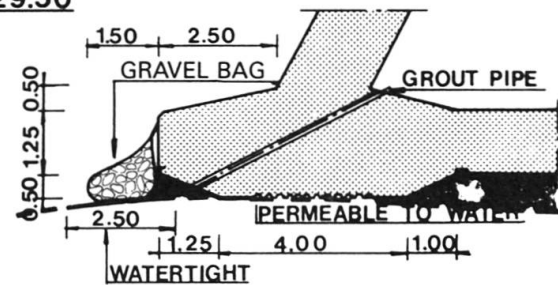

Fig. 8 Gravel bag

Bottom slab of pier

After the piers have been placed, complete filling of the cavity between the foundation bed and the underside of the bottom slab of each pier has to take place; it is essential that the filling should not be washed out to prevent underflow and irregular settlement. Even after the final operation of cleaning the surface of the foundation bed in readiness for receiving the pier, it is possible that a layer of sand up to 10 cm thick may be deposited on it. This will have to stay where it is, even though it is likely to have an unfavourable effect on the efficiency of the seal between the bottom slab and the foundation bed. At first it was thought that the problem could be avoided by providing the bottom slab with a «skirt» formed of steel sheet piling, the idea being that the weight of the pier and the force exerted by the lifting vessel would thrust the 1 m long skirt into the foundation bed. It was estimated that this would demand a penetration force of 40-60 tons per linear metre to achieve a

penetration of 0.80 m. However, on account of inevitable local variations in the resistance of the bed, there would be variations in the force actually developed around the perimeter of the pier. In order to set the bottom slab correctly horizontal under such circumstances, the lifting vessel would have to exert corrective forces. This would in turn have made the design of the vessel more elaborate and therefore more expensive. Further investigation revealed moreover that the skirt could not be designed to be sufficiently strong to withstand the horizontal loads that would develop in the final stage of construction. There was also a considerable risk that the steel sheet piling of which it consisted would eventually be destroyed by corrosion. For these reasons the idea of the skirt was abandoned and it was decided instead to install «gravel-bags» around the pier foot (Fig. 8).

(J. M. van Geest)