

Zeitschrift: IABSE structures = Constructions AIPC = IVBH Bauwerke
Band: 8 (1984)
Heft: C-31: Storage tanks

Artikel: LNG Terminal at Zeebrugge (Belgium)
Autor: Simonis, J.L.
DOI: <https://doi.org/10.5169/seals-18834>

Nutzungsbedingungen

Die ETH-Bibliothek ist die Anbieterin der digitalisierten Zeitschriften. Sie besitzt keine Urheberrechte an den Zeitschriften und ist nicht verantwortlich für deren Inhalte. Die Rechte liegen in der Regel bei den Herausgebern beziehungsweise den externen Rechteinhabern. [Siehe Rechtliche Hinweise.](#)

Conditions d'utilisation

L'ETH Library est le fournisseur des revues numérisées. Elle ne détient aucun droit d'auteur sur les revues et n'est pas responsable de leur contenu. En règle générale, les droits sont détenus par les éditeurs ou les détenteurs de droits externes. [Voir Informations légales.](#)

Terms of use

The ETH Library is the provider of the digitised journals. It does not own any copyrights to the journals and is not responsible for their content. The rights usually lie with the publishers or the external rights holders. [See Legal notice.](#)

Download PDF: 15.03.2025

ETH-Bibliothek Zürich, E-Periodica, <https://www.e-periodica.ch>



1. LNG Terminal at Zeebrugge (Belgium)

Owner: *Distrigaz SA, Brussels*
Engineer: *Tractebel Engineering*
Contractors: *Frabeco-Francois-CFE*
Construction time: *4 years*
Operation: *1986*

The construction of a LNG terminal with three storage tanks is actually in progress at Zeebrugge, on the Belgian sea shore. This terminal is managed by the company Distrigaz.

The construction of one storage tank takes about three and a half years.

Each unit consists of an excavation liner in which the storage tanks themselves are built.

This watertight excavation liner consists a.o. of a 1,2 m thick cylindrical diaphragm wall of reinforced concrete which penetrates into the bartoon clay situated at -40 m and of a 3,20 m thick foundation slab also of reinforced concrete.

The storage unit itself is a kind of gigantic thermos flask. The inner bottle, a cylindrical tank with a diameter of 72 m and a height of 23 m, has a capacity of 87.000 m³ and mainly consists of about 1.000 t 9 % Ni steel.

The nickel alloy and the special thermal treatments of this high quality steel ensure that the tank is resistant to the very low temperature, i.e. min. -163°C. At this temperature the natural gas (LNG = liquid natural gas) is liquid indeed and can be stored as such with a volume reduction of 600 compared to the gaseous state. Without nickel the steel would at that temperature be as fragile as glass. 3.000 t 9 % Ni steel delivered by la

Fabrique de Fer de Charleroi, a Belgian steel producer well known for its high quality plates.

The outer wall of the thermos flask also consists of a 0,9 m thick cylindrical tank of heavily reinforced and pre-stressed concrete and internally lined with a 3,5 mm thin vertical tight steel liner. For this tight steel liner of the inner tank about 1.000 t steel per tank was also ordered from Belgian suppliers. The spherical dome of this outer tank has a 16 mm thick plate structure, radially and concentrically reinforced, on which the concrete is poured.

The space between both tanks is provided with adequate insulating materials in order to limit the evaporation of the liquid.

The quality of the construction of these storage units is ensured by the organization of inspection and control system, proper to the contractor, who takes care that at every delivery and fabrication stage, the necessary controls are being made with regard to quality and conformity and in this respect can guarantee that each defect or failure is discovered and repaired. It is obvious that recognized inspection organisms are involved: SECO for the civil engineering works, A.I.B. for the metallic construction and VINCOTTE for the equipments.

The steel parts are pre-fabricated and pre-assembled in the workshops of the constructional steelwork Boelwerf at Temse.

This realization is adding to the experience gained in 1976 in the construction of LNG and liquid nitrogen tanks of the peak-shaving installation for Distrigas at Dudzele, a very significant and in Belgium unique reference.

(J.L. Simonis)

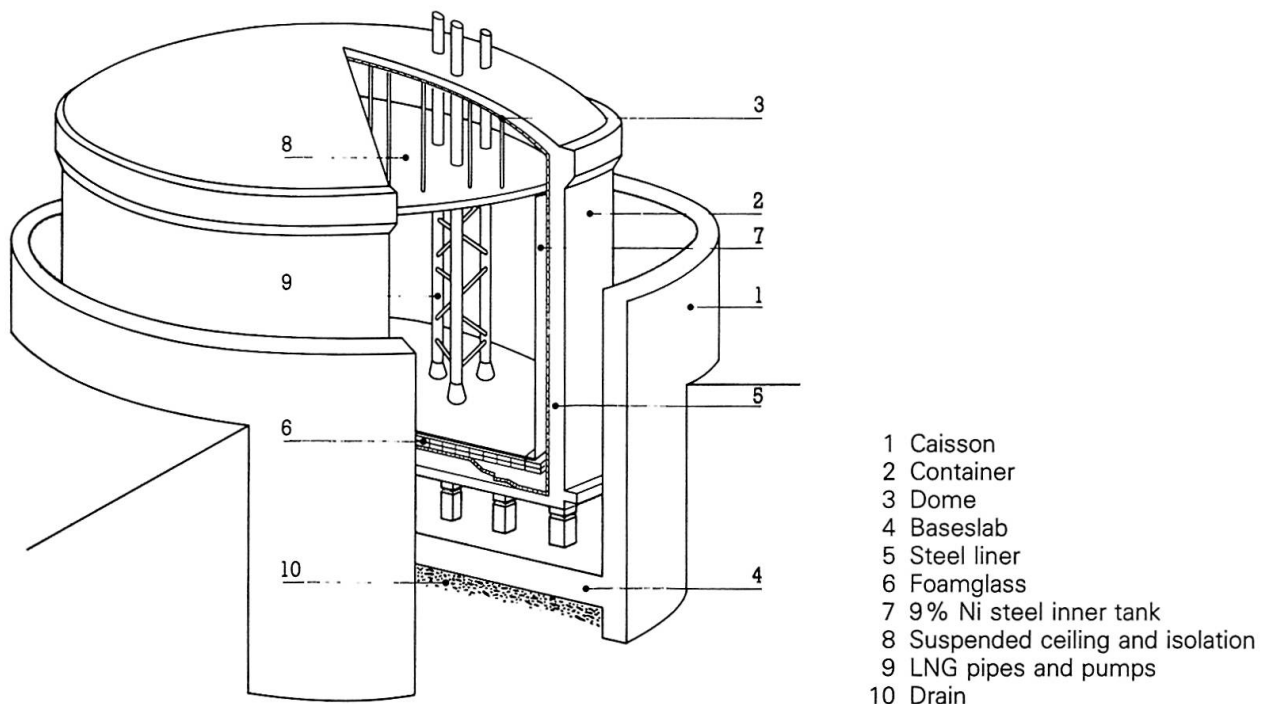

- 1 Caisson
- 2 Container
- 3 Dome
- 4 Baseslab
- 5 Steel liner
- 6 Foamglass
- 7 9% Ni steel inner tank
- 8 Suspended ceiling and isolation
- 9 LNG pipes and pumps
- 10 Drain

