

Zeitschrift: IABSE structures = Constructions AIPC = IVBH Bauwerke
Band: 10 (1986)
Heft: C-36: Structures in Japan

Artikel: 1000 kV transmission tower
Autor: Yamagishi, H.
DOI: <https://doi.org/10.5169/seals-19857>

Nutzungsbedingungen

Die ETH-Bibliothek ist die Anbieterin der digitalisierten Zeitschriften. Sie besitzt keine Urheberrechte an den Zeitschriften und ist nicht verantwortlich für deren Inhalte. Die Rechte liegen in der Regel bei den Herausgebern beziehungsweise den externen Rechteinhabern. [Siehe Rechtliche Hinweise.](#)

Conditions d'utilisation

L'ETH Library est le fournisseur des revues numérisées. Elle ne détient aucun droit d'auteur sur les revues et n'est pas responsable de leur contenu. En règle générale, les droits sont détenus par les éditeurs ou les détenteurs de droits externes. [Voir Informations légales.](#)

Terms of use

The ETH Library is the provider of the digitised journals. It does not own any copyrights to the journals and is not responsible for their content. The rights usually lie with the publishers or the external rights holders. [See Legal notice.](#)

Download PDF: 18.03.2025

ETH-Bibliothek Zürich, E-Periodica, <https://www.e-periodica.ch>



10. 1000 kV Transmission Tower

Owner: Tokyo Electric Power Co., Inc.
Engineer: Transmission & Transformation Facilities Construction Administration

Outline of 1000 kV Transmission Line

System Voltage: 1000 kV
Circuits: 2 cct
Conductor: ACSR 810 mm² × 8
Overhead
Grand Wire: AS 320 mm²
Route Length: 250 km
Nb of Towers: 550
Total Weight of Towers: 150 000 ton
Type of Structure: Trussed Tubular Tower

Construction Period: 1988 ~ 1993

Introduction

The Tokyo Electric Power Co., Inc., constructed the 500 kV Shin-Niigata Transmission Line in 1984 to transmit power generated at the Kariha-Kashiwazaki Nuclear Power Station which was put into operation in 1985. This line has a capacity for transmitting power generated by only three atomic power units. Therefore, until additional units are constructed, another transmission line must be constructed.

For this new line, as system voltage, 1000 kV was adopted because a 1000 kV transmission line gives less transmission loss and has a large capacity for transmitting power over long distances from remote power plants. Thus the following survey was started for designing a practical and economical 1000 kV line.

For 1000 kV transmission various kinds of studies and proof tests have been conducted nationwide since

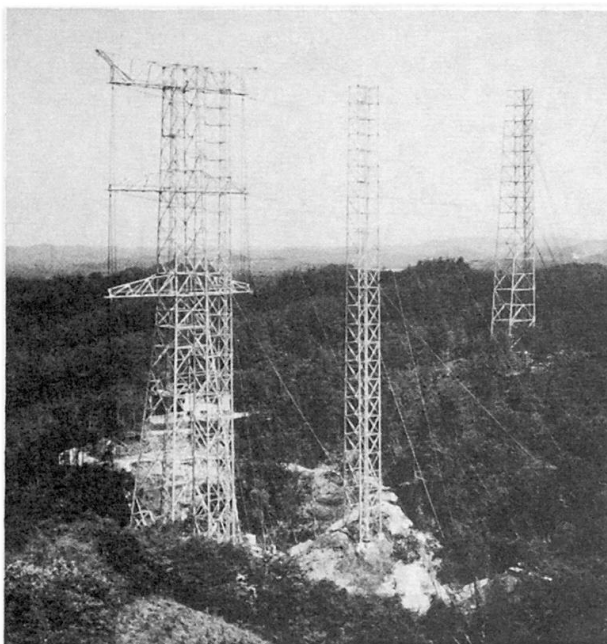

Full-scale Tower Tests

1973. Among them, new high-tensile steel has been developed and the tower structures have been improved. As a result of these efforts, the total steel weight was reduced by approximately 15% and the total cost of the transmission line by approximately 3%. Proof tests for a full scale tower are being conducted to confirm the reliability of the streamlined tower.

Design and Streamlining the Steel Tower

Figure 1 shows an example of the 1000 kV tangent-type tower. This tower is designed in accordance with the Technical Standards of Electrical Facilities and the Design Standards on Structures for Transmissions. The main postmembers and bracing members use steel tubes which have small drag coefficients.

In UHV towers, the following new techniques and ideas are to be employed to reduce the weight of the tower.

Development of a New Steel Material

Tower columns have used high tensile steel, that is, STK55 (55 kg/mm² in tensile strength) so far, but in order to reduce the weight, the possibility of higher tensile steel has been studied. 80 kg/mm² high-tensile steel has been considered for example. However, it has proved to be uneconomical because it needs heat treatment which increases costs proportionately more than the strength. Then a manufacturable range of strength was studied with respect to non-heat treatment steel. As a result steel of 60 kg/mm² tensile strength has proved to be suitable. Recently, however, steel towers are becoming increasingly larger, and thermal stress generated in each part of the steel tubes in hot dipped galvanizing and hardening of steel are considered to generate cracks together. Therefore, alloy elements were determined which were able to withstand these phenomena. This 60 kg/mm² high tensile steel was found to be suitable for flange joints and gusset plates used for connection of the members as well as for steel tubes used for columns. As a result of introducing new steel material, the tower weight is reduced by 7%.

Improvement of Connection

The gusset plates to connect steel tower members account largely for the weight of the steel tower. Use of eccentric connections shown in Figure 2 reduces the tower weight by approximately 3%. For practical use of this eccentric connection, however, the effects of eccentricity on the strength of the connections and on the buckling strength of columns and bracing must be studied. By partial tests of the tower and small-scale tests, the behaviors of each part were measured and compared with analytical values, and a design method has been established. In addition, confirmation tests are being conducted using a full-scale steel tower.

Optimization of Structural Frame

While the inclined angle of bracing of steel towers was 40° to 45° for a 500 kV steel tower, as shown in Figure 3, that for the 1000 kV steel tower was made equal to 45°

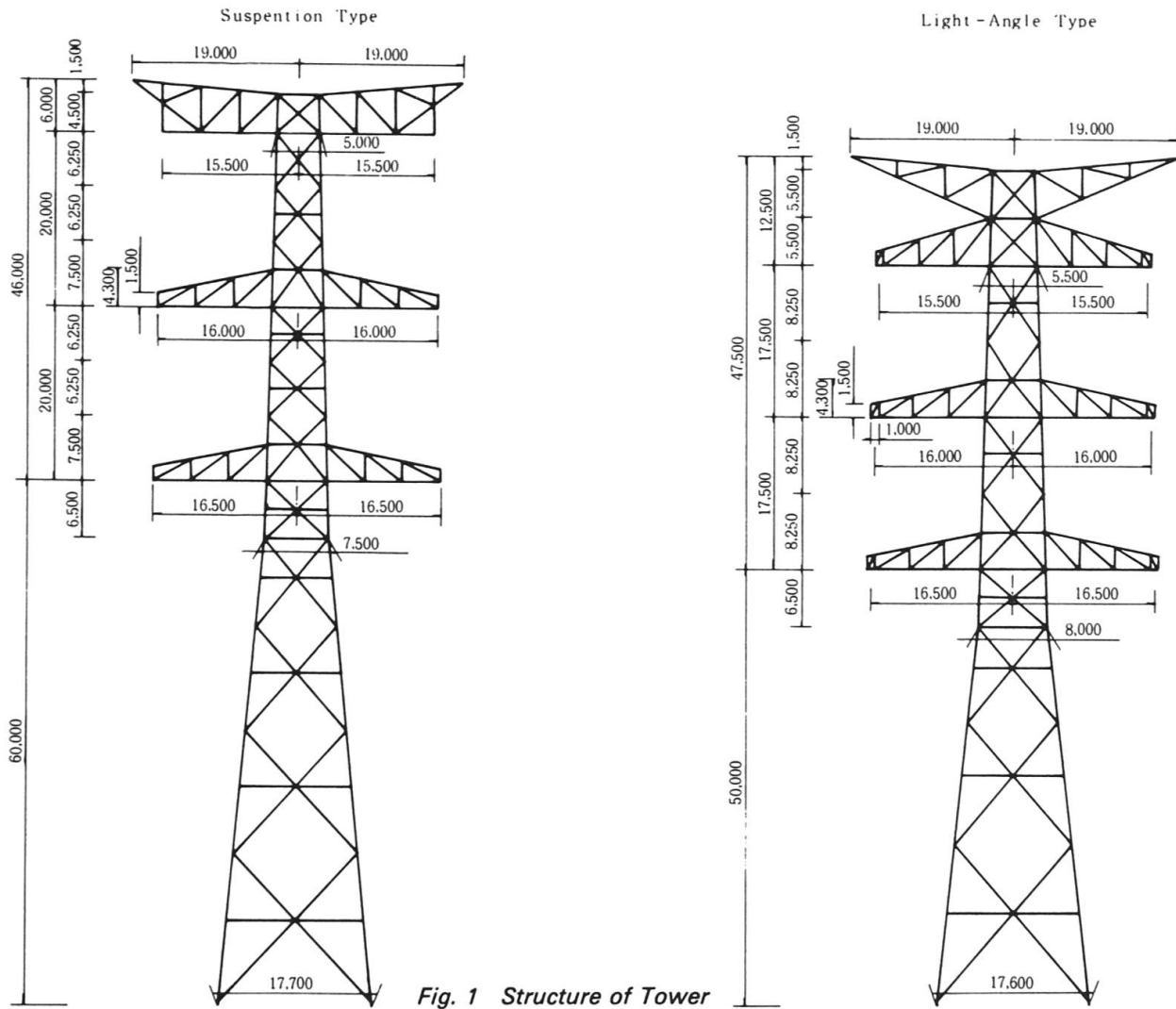

Fig. 1 Structure of Tower

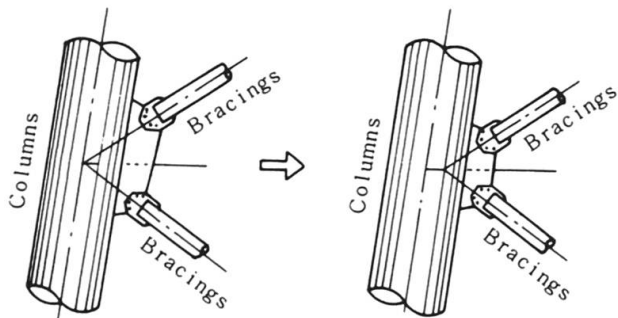

Fig. 2 Improvement of Connection

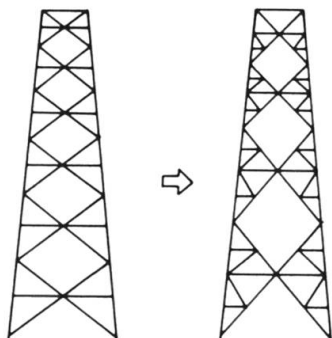

Fig. 3 Optimization of Structural Frame

to 50° after studies, reducing the steel tower weight by approximately 3%. However, since many reinforcement members are needed to increase the angle bracing, the effects on them are finally being confirmed by conducting full-scale tower tests.

Full-scale Tower Tests

In order to confirm the reliability of the 1000 kV tower, design load tests are being conducted. In these tests, free vibration tests are being conducted at a large amplitude of vibration and tests in which displacement is given to pedestals to examine the behavior of the steel tower are being conducted in anticipation of displacement of the foundations.

The test steel towers used anticipate both flat and sloping ground, and include those with the foundation and upper parts connected.

These tests are being conducted in the Motegi Large-scale Tower Testing Facility of the Tomoegumi Iron Works Ltd. having modern loading and measurement equipment, such as a recently constructed rigid test foundation supporting a tower height of 110 meters and a moment carrying capacity of 50,000 tm.

(H. Yamagishi)