

**Zeitschrift:** IABSE structures = Constructions AIPC = IVBH Bauwerke  
**Band:** 10 (1986)  
**Heft:** C-39: Energy-conservative buildings in warm climates

**Artikel:** Yulara Tourist Resort, Ayers Rock, NT (Australia)  
**Autor:** Stapleton, T.  
**DOI:** <https://doi.org/10.5169/seals-19885>

### **Nutzungsbedingungen**

Die ETH-Bibliothek ist die Anbieterin der digitalisierten Zeitschriften. Sie besitzt keine Urheberrechte an den Zeitschriften und ist nicht verantwortlich für deren Inhalte. Die Rechte liegen in der Regel bei den Herausgebern beziehungsweise den externen Rechteinhabern. [Siehe Rechtliche Hinweise.](#)

### **Conditions d'utilisation**

L'ETH Library est le fournisseur des revues numérisées. Elle ne détient aucun droit d'auteur sur les revues et n'est pas responsable de leur contenu. En règle générale, les droits sont détenus par les éditeurs ou les détenteurs de droits externes. [Voir Informations légales.](#)

### **Terms of use**

The ETH Library is the provider of the digitised journals. It does not own any copyrights to the journals and is not responsible for their content. The rights usually lie with the publishers or the external rights holders. [See Legal notice.](#)

**Download PDF:** 18.03.2025

**ETH-Bibliothek Zürich, E-Periodica, <https://www.e-periodica.ch>**



## 6. Yulara Tourist Resort, Ayers Rock, NT (Australia)

*Architect:* Philip Cox & Partners  
*Services Engineer:* D S Thomas, Weatherall & Associates PTY Ltd  
*Project Manager:* White Industries Limited  
*Occupancy Date:* 1983/1984

The Resort was developed in one of the most remote locations in Australia to include:

- an international class hotel
- a superior class motel
- cabin accommodation
- camping and caravan parks
- staff quarters
- housing
- display centres
- village support facilities

### Building Passive Energy Design

A variety of passive energy techniques were incorporated into the building to assist in the reduction in consumption of active energy systems required to provide suitable internal environments and municipal services.

### Building Passive Energy Design

The most significant of these techniques were aimed at taking advantage of large seasonal and diurnal changes in ambient temperature.

- High thermal mass associated with concrete block and concrete construction produced beneficial storage of heat.
- External shading with fabric shades or verandah structures to exclude high elevation summer sun but allow penetration of winter radiation.
- Double roof construction with ventilated roof space to reduce summer heat gain.
- Building orientation such that the long axis of most buildings is east/west.
- Specialised roof claddings to maximise reflectance from the upper surface and to minimise radiation from the lower surface.

### Total Energy Engineering Design

The design theme for the development of engineering services for the Resort was the economic use of all available resources at the site.

The predominant influence prevailing in this location is the extremes of daily and seasonal temperature, high levels of solar radiation and limited water supplies of low quality.

The village services systems were developed to respond to prevailing influences and to make use of a diesel generating power facility that had been developed by the Northern Territory Electricity Commission.

A total energy concept was conceived to provide:

- Minimum consumption of utility energy by the use of energy efficient services and by the maximum economic use of solar energy
- Control of the maximum instantaneous demand for utility energy by the use of thermal storage (ice) and the use of thermal storage to gain maximum benefit from winter time solar radiation.

### Mechanical Services

The major facilities of the Village are served by a Central Energy Plant which provides chilled water for space cooling and hot water for space heating and heating of consumable hot water.

The plant operates in seasonal modes.

During winter, solar heat energy is collected in the 3000 m<sup>2</sup> of flat plate collectors. This heat is transferred into ice storage tanks during the day and is stored by melting prepared ice. As the demand for heating occurs, the refrigeration equipment "heat pumps" this heat to hot water stores at 50°C and reforms the ice store for use the following day.

During summer, off peak operation of the refrigeration equipment produces ice at times when other forms of electrical demand are reduced. Ice is available during the day to meet cooling demands, with the ice stored being flexibly used to meet peak cooling demands without there being a need for refrigeration plant to be capable of meeting instantaneous demand. The storage facility allows extended running of small plant in an off peak mode to satisfy the day demand.

Heat rejected from the refrigeration equipment is rejected to atmosphere, during Summer, at the most advantageous times, by operating closed circuit coolers at times of reduced ambient temperature.

Solar collectors are used in summer, during the day, for high temperature heating of calorifiers.

During the mid seasons heating and cooling demands are both experienced during each day. The nature of the heat pump plant allows these demands to be simultaneously met by using heat extracted during day time building cooling for night time heating.

### Water Supply

Water is extracted from an underground aquifer system and is treated by a high efficiency electro-dialysis reversal plant to provide suitable consumable water.

Water for such activities as toilet flushing and fire protection is not treated.

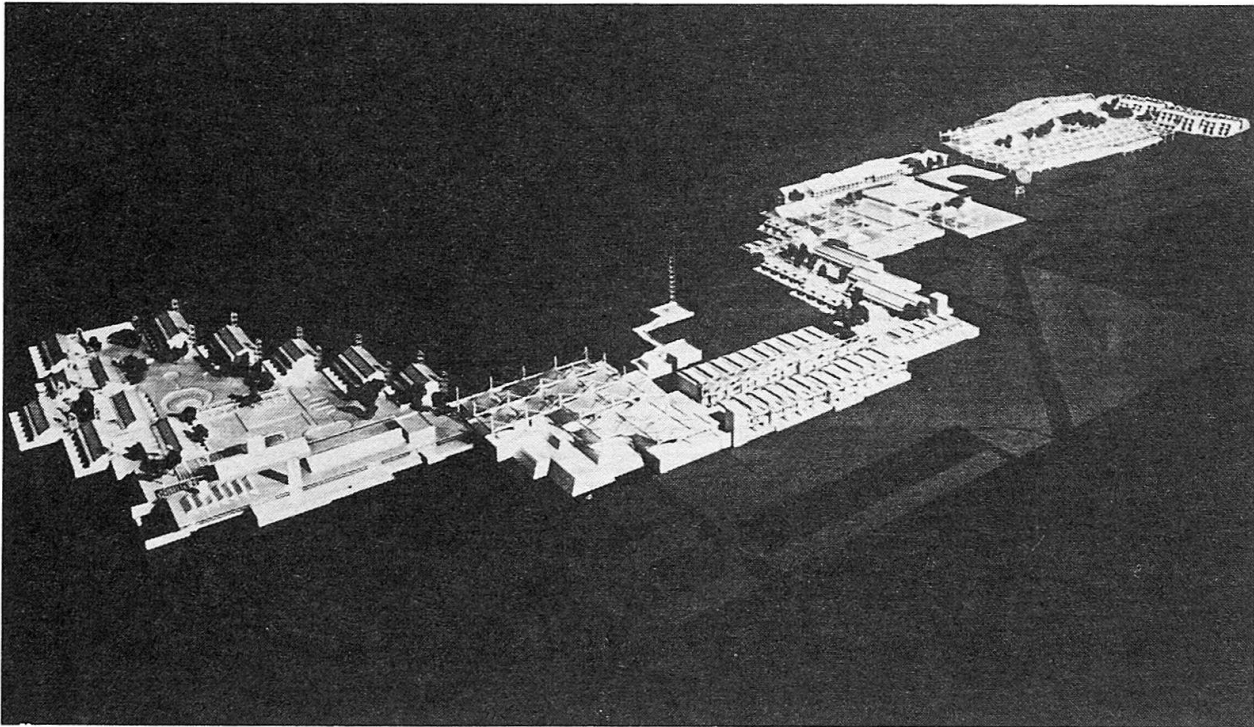

Fig. 1. Yulara Tourist Resort

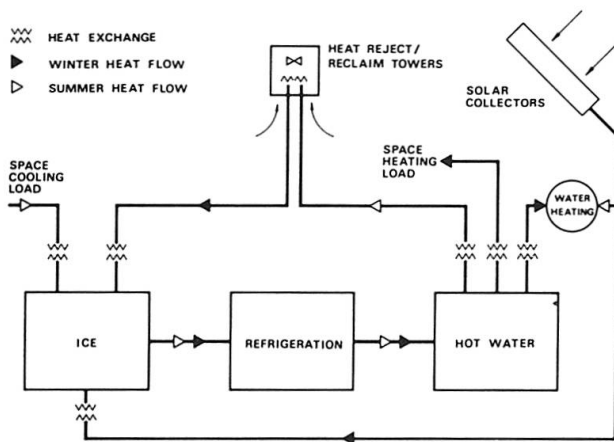

Fig. 2. Yulara Energy Diagram

### Waste Water Treatment

Treatment of the Village waste water is undertaken using the activated sludge process.

Effluent from this plant is of reliable quality and following chlorination, is returned to the Village for use in irrigation systems. The re-use of water in this manner reduces the demand for relatively energy expensive treated water.

### Summary

The energy design for Yulara represents the integration of building design, services engineering design, high energy cost due to remoteness, and a desert environment.

The use of flat plate collectors at very low temperatures in the winter contributes very heavily to their economic viability and to reductions in energy costs.

(T. Stapleton)