

Zeitschrift: IABSE structures = Constructions AIPC = IVBH Bauwerke
Band: 13 (1989)
Heft: C-48: Structures in Portugal

Artikel: Soporcel wood paste plant, Leirosa (Portugal)
Autor: Pompeu Santos, S. / Cachadinha, M.
DOI: <https://doi.org/10.5169/seals-21558>

Nutzungsbedingungen

Die ETH-Bibliothek ist die Anbieterin der digitalisierten Zeitschriften. Sie besitzt keine Urheberrechte an den Zeitschriften und ist nicht verantwortlich für deren Inhalte. Die Rechte liegen in der Regel bei den Herausgebern beziehungsweise den externen Rechteinhabern. [Siehe Rechtliche Hinweise.](#)

Conditions d'utilisation

L'ETH Library est le fournisseur des revues numérisées. Elle ne détient aucun droit d'auteur sur les revues et n'est pas responsable de leur contenu. En règle générale, les droits sont détenus par les éditeurs ou les détenteurs de droits externes. [Voir Informations légales.](#)

Terms of use

The ETH Library is the provider of the digitised journals. It does not own any copyrights to the journals and is not responsible for their content. The rights usually lie with the publishers or the external rights holders. [See Legal notice.](#)

Download PDF: 22.01.2025

ETH-Bibliothek Zürich, E-Periodica, <https://www.e-periodica.ch>



7. Soporcel Wood Paste Plant, Leirosa (Portugal)

Owner: Soporcel SA
Engineers: GAPRES Lda and ENARCO Lda
Contractors: ENGIL, SOMEK, ILÍDIO MONTEIRO
Works Duration: 30 months
Service date: 1986
Material quantities:
 Concrete 72 000 m³
 Steel 7000 ton
 Piles 72 000 m

General

The Soporcel wood paste plant has an area of 1.5 km², 0,70 of them occupied with constructions. The production capacity is 1200 ton of paste per day.

The constructions are many and of different types of structure. They are in general in reinforced concrete but some are in steel. The main structures are: the buildings for the pulp preparation and for the paste machine in the department of paste preparation; the building for the recuperation boiler and the chimney of the power plant; the clarifiers and the water reservoir of the water treatment station; and the primary clarifiers and the aeration tanks in the effluents treatment station.

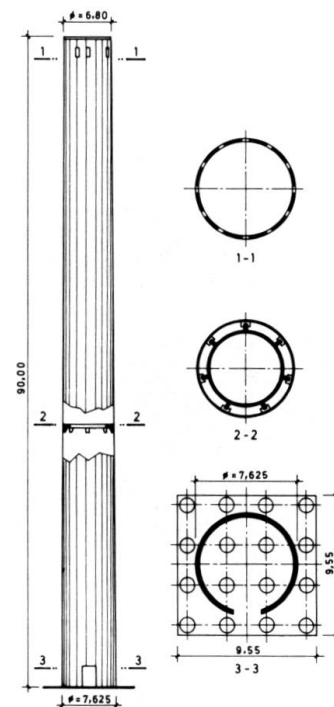

Fig. 2 Geometry of the chimney

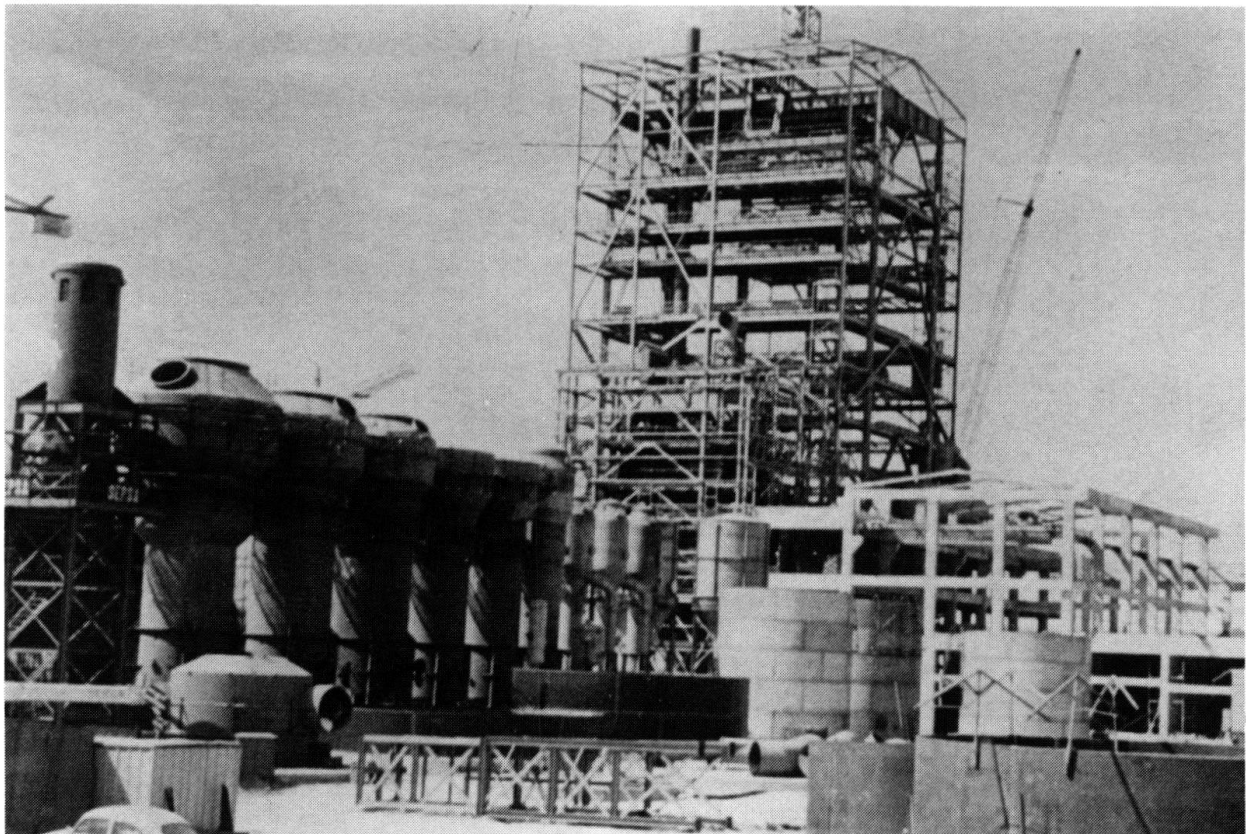

Fig. 1 Partial view of the plant

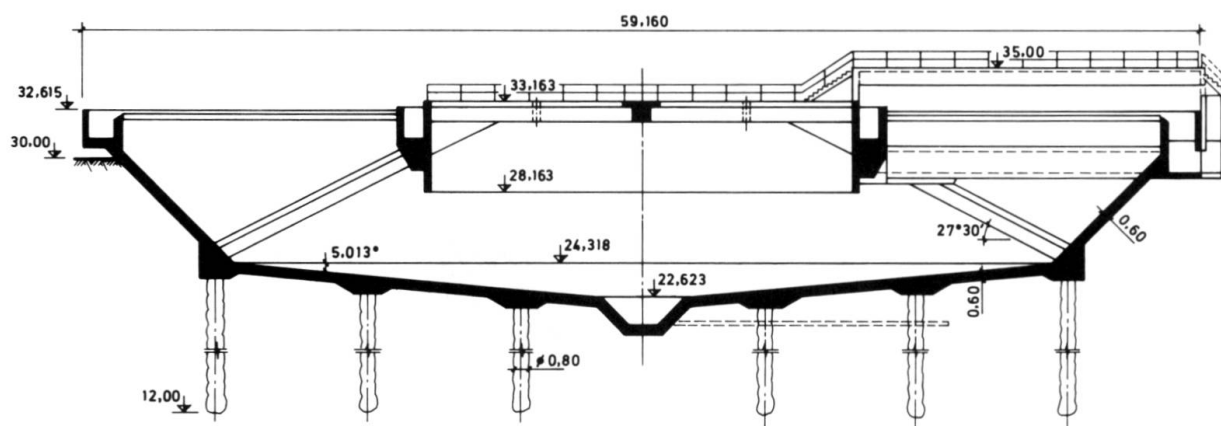

Fig. 3 Geometry of the primary clarifiers

Foundations

The bad conditions of the superficial soil on the site impose the adoption of different types of foundation, according to the type and to the weight of the construction. The light constructions were founded directly, in general after the treatment of the soil. The heavy constructions have indirect foundations with cast-in-situ concrete piles. Anchored concrete piles were also used in partially buried light structures, in order to mobilize the weight of the soil against the ground water pressure.

Structures

The pulp building has 133 m × 21 m in plan and is 21 m high. It has a reinforced concrete structure with transversal and longitudinal frames modulated 7 m × 7 m and divided into 3 blocks by expansion joints.

The paste machine building has 182 m × 28 m in plan and is 18 m high. The structure is identical to that of the pulp building. The roof structure is a steel truss with a 28 m span.

The recuperation boiler building has 26 m × 25 m in plan and is 55 m high. The structure is a steel space frame braced in horizontal and vertical directions (Fig. 1).

The chimney is in concrete and is 90 m high with an exterior diameter of 7 m (Fig. 2).

The clarifiers of the water treatment station are tanks with the shape of an inverted frustum of cone with 42 m diameter at the top and 33 m at the base and with a height of 6 m. Resting on beds of compacted gravel and sand.

The water reservoir is a reinforced concrete tank with 35 000 m³ capacity. It has 80 m × 70 m in plan, 8 m in height and is partially buried. The foundations are concrete piles disposed in the alignment of the columns that support the roof disposed in a mesh of 6,4 m × 6,4 m.

The primary clarifiers of the effluent treatment station are concrete tanks with shape of a double inverted frustum of cone. It has a 59 m diameter at the top and a 44 m diameter at the bottom and is 10 m high. They are partially buried and have pile foundations disposed in 3 concentric ribs (Fig. 3).

The aeration basin is a double tank with 80 m × 80 m in plan and is a 6 m high. They are also partially buried and have piles foundations.

Structural analysis and design

Structures were designed according to the Portuguese Code on Actions and with the loads indicated in the guide-drawings of the «lay-out».

The characteristics of the soil foundation of the structures were obtained from a complex geotechnic study carried out.

In the structural calculations reliable models of analysis were considered depending on the importance and complexity of the structure. CAD was in general used.

The buildings were in general realized as plane frames in two directions.

The chimney was realized as a vertical cantilever fixed in the ground, taking into account the flexibility of the soil. For horizontal actions a dynamic analysis was made.

The clarifiers were analyzed with models of axis-symmetric equilibrium shell elements, calculated by the finite element method. In these models the main parts of the structure and the adjacent soil were considered. For the primary clarifiers of the effluent treatment station, for example, the structure, the piles and the soil were divided into 591 elements, forming a mesh of 523 nodes. In these analysis the radial, vertical, diametral and tangential stress and the principal stresses in the center of the elements were obtained. Displacements and the previous settlements were also obtained.

(S. Pompeu Santos, M. Cachadinha)