

The new Douro Railway Bridge, Oporto (Portugal)

Autor(en): **Freitas C. / Branco F.**

Objektyp: **Article**

Zeitschrift: **IABSE structures = Constructions AIPC = IVBH Bauwerke**

Band (Jahr): **13 (1989)**

Heft C-50: **Recent structures**

PDF erstellt am: **22.07.2024**

Persistenter Link: <https://doi.org/10.5169/seals-21568>

Nutzungsbedingungen

Die ETH-Bibliothek ist Anbieterin der digitalisierten Zeitschriften. Sie besitzt keine Urheberrechte an den Inhalten der Zeitschriften. Die Rechte liegen in der Regel bei den Herausgebern.

Die auf der Plattform e-periodica veröffentlichten Dokumente stehen für nicht-kommerzielle Zwecke in Lehre und Forschung sowie für die private Nutzung frei zur Verfügung. Einzelne Dateien oder Ausdrucke aus diesem Angebot können zusammen mit diesen Nutzungsbedingungen und den korrekten Herkunftsbezeichnungen weitergegeben werden.

Das Veröffentlichen von Bildern in Print- und Online-Publikationen ist nur mit vorheriger Genehmigung der Rechteinhaber erlaubt. Die systematische Speicherung von Teilen des elektronischen Angebots auf anderen Servern bedarf ebenfalls des schriftlichen Einverständnisses der Rechteinhaber.

Haftungsausschluss

Alle Angaben erfolgen ohne Gewähr für Vollständigkeit oder Richtigkeit. Es wird keine Haftung übernommen für Schäden durch die Verwendung von Informationen aus diesem Online-Angebot oder durch das Fehlen von Informationen. Dies gilt auch für Inhalte Dritter, die über dieses Angebot zugänglich sind.



1. The New Douro Railway Bridge, Oporto (Portugal)

Owner: Gabinete di Nó Ferroviário do Porto (Railway State Administration Committee)

Designer: Edgar Cardoso

Contractors: Soares da Costa, SA
Teixeira Duarte, SA
Ilídio Monteiro, SA
OPCA, SA

Works Duration: 60 months

Service Date: 1990

General

The actual river Douro crossing consists of a single track railway line where the centenarian Maria Pia bridge is located, a steel arch built by Gustave Eiffel in 1877. This situation leads to important traffic restrictions, in this zone, which is part of the main railway line to the North of Portugal. To solve this problem a new double track line is now under construction between Porto (Campanhã) and Vila Nova de Gaia (Fig. 1). The new line, 3.4 km long, has several viaducts, a tunnel under Vila Nova de Gaia, the new General Torres Railway Station and the Douro bridge.

Description

The structure for the new crossing of the river Douro consists of a main bridge and two approach viaducts with a total length of 1028 m (Fig. 2).

The main bridge has a central span of 250 m and two lateral spans of 125 m. The south viaduct is 358 m ($58 + 5 \times 60$ m) long and the north one is 170 m ($50 + 2 \times 60$ m) long. The total superstructure has no joints along its length between abutments. The viaducts' decks are continuous beams supported by roller bearings on the top of the columns. The two central main columns are rigidly connected to the superstructure, which leads to a frame type behaviour of the main bridge.

The central columns have a varying cross section with an external hyperboloid shape along their height. They have an hollow section from the base (circular with $r = 9$ m) up to the level 25 m. Upwards, to the top (level 52 m) the section has two holes only for services.

The superstructure is a double cell box with varying height from 7.0 m at midspan to 14 m at the columns. The top flange has a constant width of 12 m (Fig. 3). The rail track is balastless and the rails are directly connected to concrete longitudinal beams supported by the top slab.



Fig. 1 Overall view (photomontage)

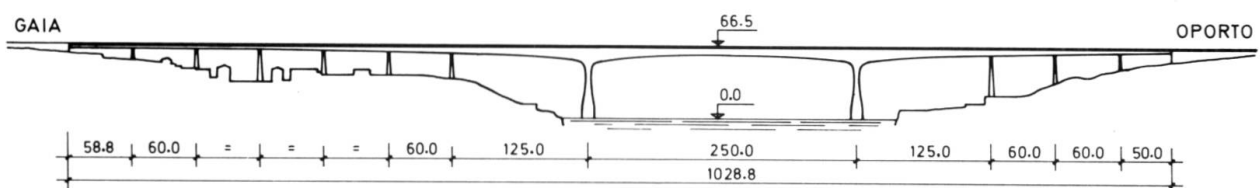

Fig. 2 Side elevation

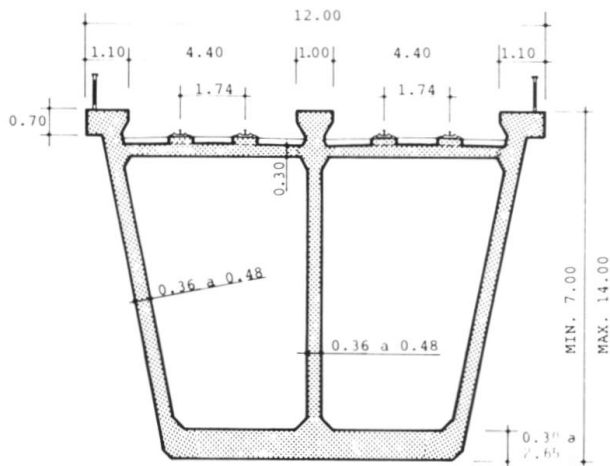

Fig. 3 Typical deck cross section

The main bridge and its viaducts are built in prestressed concrete, highly reinforced. The superstructure has longitudinal and vertical prestressing.

As mentioned above, the overall structure has joints only at the abutments. Here there are special devices that make the structure free for longitudinal slow movements (temperature effects) and join it to the abutments for quick actions (breaking and seismic forces).

The foundations of the main central columns were built using steel cofferdams placed inside the river. A group of special micro piles (each with $\varnothing = 250$ mm reinforced with 5×50 mm bars, A 500 NR) were then driven into the bedrock, with a radial distribution, to ensure the connection between the columns and the deep hard bedrock.

Construction

The main bridge is being built by the cantilever method with 125 m span cantilevers (Fig. 4). The initial segments, near the columns, are 5 m long and the current ones are 7.5 m long. The formwork and the supporting truss system were specially designed for this bridge. The height of the vertical formwork is reduced, along the span, during construction.

An observation laboratory was built near the bridge to control the structure's movements during construction. A segment of the superstructure was built near this laboratory for training the construction workers and to check the construction operations, including the use of the formwork and supporting trusses.

(C. Freitas and F. Branco)

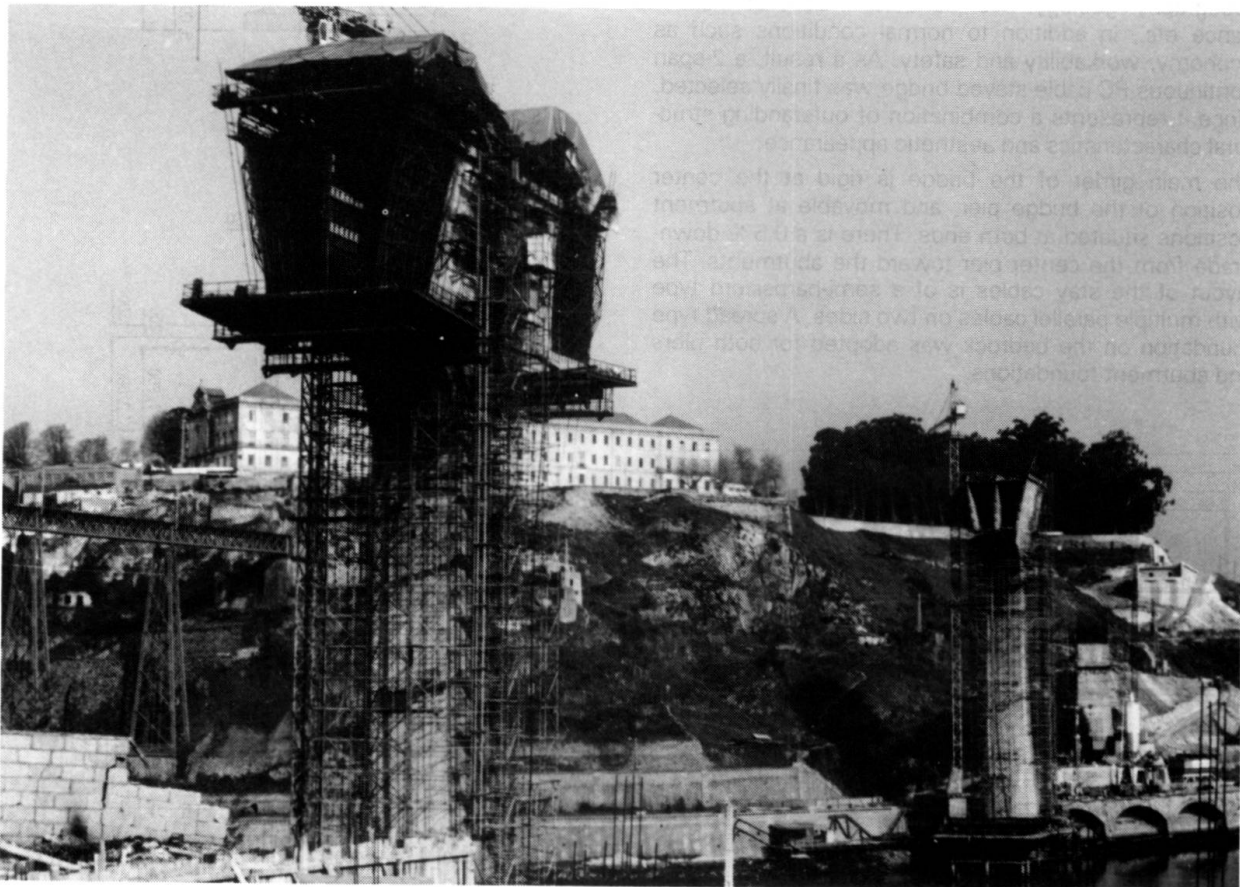

Fig. 4 Construction works view