

Schottwien Bridge (Austria)

Autor(en): **Vogler, Otto M.**

Objektyp: **Article**

Zeitschrift: **IABSE structures = Constructions AIPC = IVBH Bauwerke**

Band (Jahr): **13 (1989)**

Heft C-50: **Recent structures**

PDF erstellt am: **22.07.2024**

Persistenter Link: <https://doi.org/10.5169/seals-21571>

Nutzungsbedingungen

Die ETH-Bibliothek ist Anbieterin der digitalisierten Zeitschriften. Sie besitzt keine Urheberrechte an den Inhalten der Zeitschriften. Die Rechte liegen in der Regel bei den Herausgebern.

Die auf der Plattform e-periodica veröffentlichten Dokumente stehen für nicht-kommerzielle Zwecke in Lehre und Forschung sowie für die private Nutzung frei zur Verfügung. Einzelne Dateien oder Ausdrucke aus diesem Angebot können zusammen mit diesen Nutzungsbedingungen und den korrekten Herkunftsbezeichnungen weitergegeben werden.

Das Veröffentlichen von Bildern in Print- und Online-Publikationen ist nur mit vorheriger Genehmigung der Rechteinhaber erlaubt. Die systematische Speicherung von Teilen des elektronischen Angebots auf anderen Servern bedarf ebenfalls des schriftlichen Einverständnisses der Rechteinhaber.

Haftungsausschluss

Alle Angaben erfolgen ohne Gewähr für Vollständigkeit oder Richtigkeit. Es wird keine Haftung übernommen für Schäden durch die Verwendung von Informationen aus diesem Online-Angebot oder durch das Fehlen von Informationen. Dies gilt auch für Inhalte Dritter, die über dieses Angebot zugänglich sind.



4. Schottwien Bridge (Austria)

Client: ASAG Autobahnen- und Schnellstrassen AG

Engineer: Dipl.-Ing. Otto M. Vogler
Consulting Engineer, Vienna

Contractor: Joint venture STRABAG – Hofman & Maculan

Works' duration: 38 months

Service date: 1989

General

As part of the "Semmering"-highway (S 6), ASAG commissioned the construction of a viaduct at Schottwien, south of Vienna. Since the site of the structure, having a total length of 632.5 m and a maximum height above the valley bottom of 130 m, is an exposed location in an area of natural beauty and dominates the view afforded from Maria Schutz, a popular scenic resort, special attention was given to designing the configuration of the valley crossing.

The merits of the design, selected in the open competition and now under construction, are that the piers on both sides are located behind the projecting rocks, which are typical of Schottwien. As a result, the proportions between the two piers and the central span of 250 m are well balanced. As desired, the piers are fairly remote from the village in the valley and arranged at such sites as to provide for piers of almost equal height (max. 79 m). The piers 2 and 3 consist each of two single columns, which offers a number of structural advantages. In addition, they convey the impression of safety to the onlooker.

Foundation and slope stabilization

The abutments are hollow and dimensioned as small as possible; their ground plan is therefore a triangle. This reduces the size of the visible area and decreases the horizontal forces which require a load transfer via anchors.

The shaft foundations, proposed as pier footings, have elliptical cross-sections. For reasons of nature conservation, their dimensions were kept as small as possible (max. 15/21 m). As a result, base expansion is relatively large.

For geotechnical, static but also practical building considerations, the slope stabilizations are independent of the bridge piers and their footings.

Structural analysis and construction

The foundation was calculated for the entire system (bridge/subsoil). The building operations were assigned to 14 building phases and the so-called falsework phase, which cover the significant stresses. 42 building phases were calculated, in order to produce a detailed knowledge of the internal forces in the 154 elements, and mainly to determine deformation and the required superelevation. The main loading states were calculated according to second-order theory, taking account of the actual deformation behavior. In addition, the results were compared to the elasticity calculation and the dimensions derived by means of the omega method. Vibration and earthquake studies were made. A number of problems were solved by means of the finite element

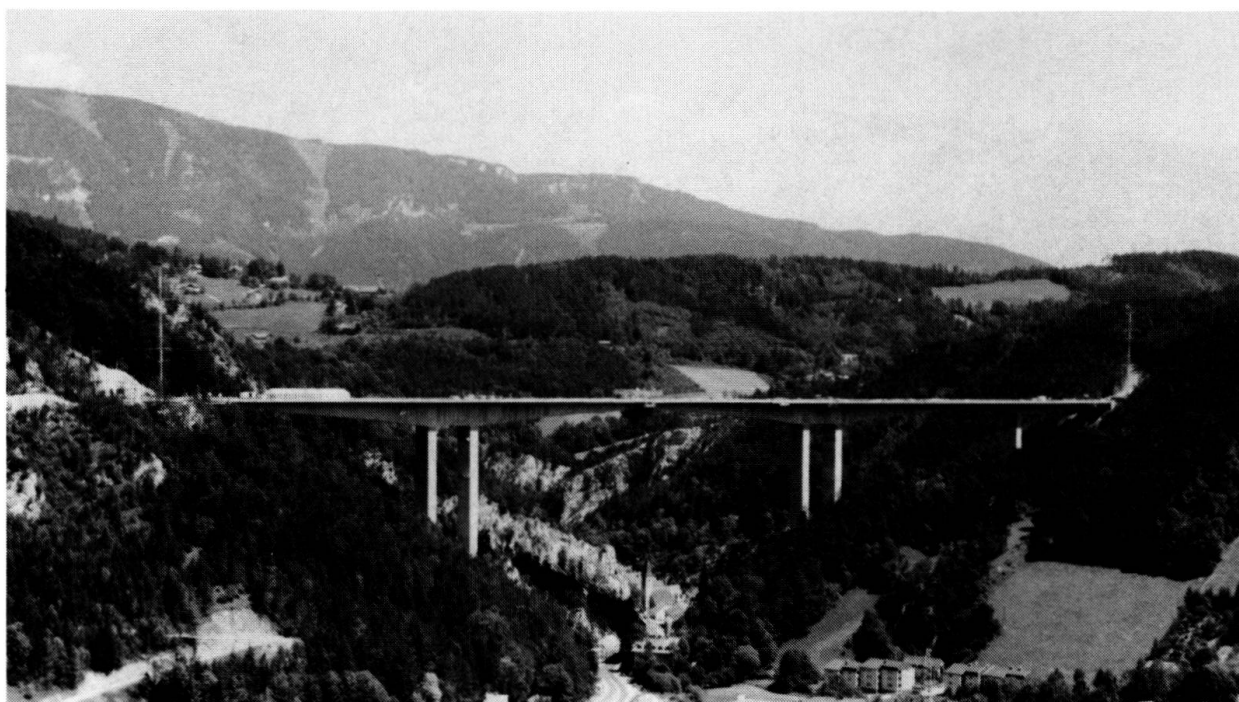

Fig. 1 Work Status, June 1989

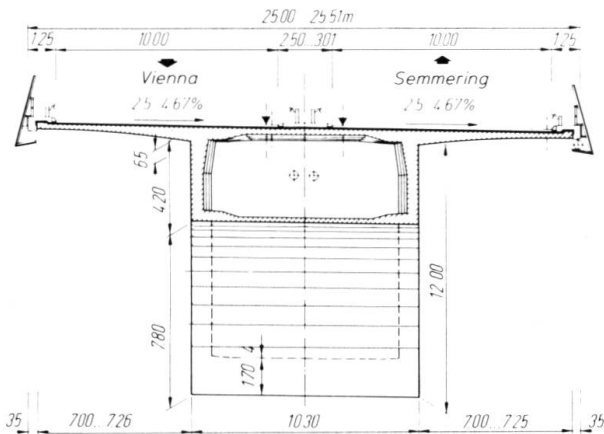

Fig. 2 Cross-section

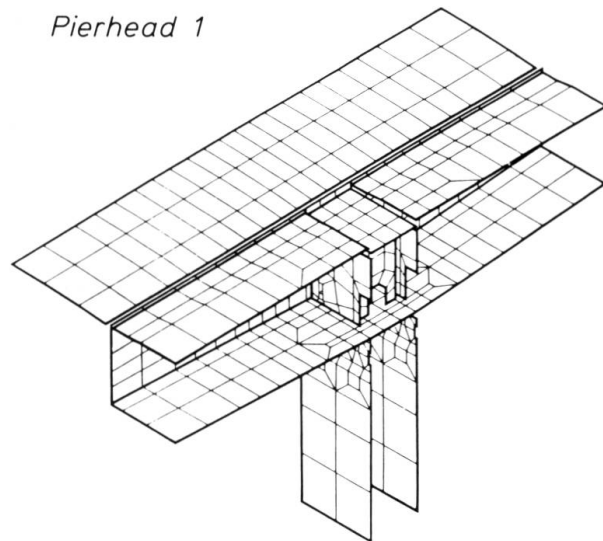

Fig. 3 FEM mesh

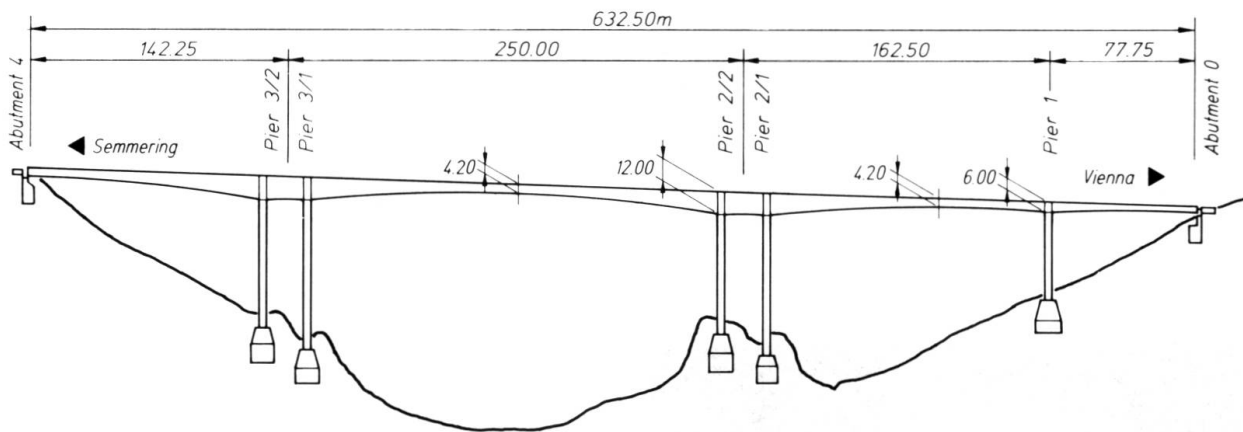

Fig. 4 Longitudinal section

method, such as internal-force determination for the deck structure, the three-dimensional system of the pierhead and many others.

The superstructure is a haunched beam made of prestressed concrete, grade B 500, by free-cantilevering. The cross-section is a single-cell hollow-box, with a lower width of 10.3 m. The roadway slab (cantilever slabs of 7.0 m) is slightly post-tensioned. The structure is restrained by the piers, which accounts for a high stiffness of the overall system. The piers are single-cell hollow-box shafts, made of concrete, grade B 500, by means of the slip-form construction method. Overall wall thickness amounts to 35 cm, expanding to a maximum of 60 cm. Pier dimensions were determined on the basis of second-order theory, to take account of actual dynamic and static stresses.

For the free-cantilevering operations altogether 222 cables, type VSL 5-19, having an admissible post-tensioning force of 2,018 kN, were located above the support. The mid-span accommodates 40 cables of the

same type, in addition to 18 cables, type VSL 5-31. VSL 5-7 cables are used for transverse post-tensioning; here, the distance varies between 61.5 and 66.5 cm.

Construction process

The superstructure consists of 139 sections, with each increment having a length between 2.75 and 5.10 m. The areas in front of the abutments (direction Vienna and direction Semmering) were produced by means of a conventional falsework, mounted on temporary concrete supports of up to 26 m height, which were removed later. The hammer-heads at piers 1, 2/2 and 3/1 were built first, using falsework. Then sections were cantilevered on either side, which accounts for a fair balance of the girders during construction. Eventually, piers 2/1 and 3/2 were reached and connected in a rigid manner. After completing the closure gaps, a continuous beam structure was obtained.

(Otto M. Vogler)