

Simplified criteria for the design of prestressed concrete structures

Autor(en): **Favre, Renaud**

Objektyp: **Article**

Zeitschrift: **IABSE proceedings = Mémoires AIPC = IVBH Abhandlungen**

Band (Jahr): **7 (1983)**

Heft P-63: **Developments in prestressed concrete structures: part II: Journées d'études AFPC-1982**

PDF erstellt am: **22.07.2024**

Persistenter Link: <https://doi.org/10.5169/seals-37494>

Nutzungsbedingungen

Die ETH-Bibliothek ist Anbieterin der digitalisierten Zeitschriften. Sie besitzt keine Urheberrechte an den Inhalten der Zeitschriften. Die Rechte liegen in der Regel bei den Herausgebern.

Die auf der Plattform e-periodica veröffentlichten Dokumente stehen für nicht-kommerzielle Zwecke in Lehre und Forschung sowie für die private Nutzung frei zur Verfügung. Einzelne Dateien oder Ausdrucke aus diesem Angebot können zusammen mit diesen Nutzungsbedingungen und den korrekten Herkunftsbezeichnungen weitergegeben werden.

Das Veröffentlichen von Bildern in Print- und Online-Publikationen ist nur mit vorheriger Genehmigung der Rechteinhaber erlaubt. Die systematische Speicherung von Teilen des elektronischen Angebots auf anderen Servern bedarf ebenfalls des schriftlichen Einverständnisses der Rechteinhaber.

Haftungsausschluss

Alle Angaben erfolgen ohne Gewähr für Vollständigkeit oder Richtigkeit. Es wird keine Haftung übernommen für Schäden durch die Verwendung von Informationen aus diesem Online-Angebot oder durch das Fehlen von Informationen. Dies gilt auch für Inhalte Dritter, die über dieses Angebot zugänglich sind.

Simplified Criteria for the Design of Prestressed Concrete Structures

Critères simplifiés pour concevoir des ouvrages en béton précontraint

Einfache Bemessungskriterien für den Entwurf von vorgespannten Bauwerken

Renaud FAVRE

Professor

Swiss Federal Institute of Technology
Lausanne, Switzerland

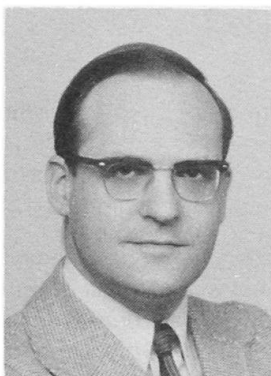

R. Favre has made his studies at the Swiss Federal Institute of Technology in Zurich where he received his diplomas in 1957. After activities in design offices and with a contractor in the field of concrete dams, bridges and buildings, he became partner of the consulting firm Schalcher and Favre. Since 1973, he is Professor of concrete structures at the Swiss Federal Institute of Technology in Lausanne.

SUMMARY

In order to stimulate an exchange of views we propose some criteria, for the design of prestressed concrete structures, which permit enormous simplification of the calculation of ultimate and service limit states, at least at the stage of preliminary design. These criteria are based on the observation of the behavior of real structures and sources of problems encountered in use. The basic guidelines are: minimum reinforcing guaranteeing small and well distributed cracks, a level of prestress eliminating or "balancing" practically all deformations of a structure resulting from permanent loads and, in addition, a simple application of plastic theory.

RÉSUMÉ

Pour susciter un échange de vues, nous proposons des critères pour la conception d'ouvrages en béton précontraint permettant de simplifier énormément les calculs de vérification des états limites ultimes et d'utilisation du moins au stade d'avant-projet. Ces critères se basent sur l'observation du comportement réel des ouvrages et des sources d'ennuis rencontrées in situ. Une armature minimale garantissant de petites ouvertures de fissures bien réparties, une précontrainte éliminant ou "balançant" pratiquement toutes les déformations d'une structure sous charge permanente ainsi qu'une application simple de la théorie de la plasticité en sont les lignes directrices.

ZUSAMMENFASSUNG

Um einen Gedankenaustausch anzuregen, schlagen wir für den Entwurf von vorgespannten Bauwerken Bemessungskriterien vor, welche die nötigen rechnerischen Nachweise für die Trag- und Gebrauchsfähigkeit zumindest im Vorprojektstadium drastisch vereinfachen. Diese Kriterien stützen sich auf die Beobachtungen über das wirkliche Verhalten von Bauwerken und auf den in situ festgestellten Sorgequellen. Eine Minimalarmierung, welche eng verteilte, kleine Rissbreiten garantiert, eine Vorspannung, welche sozusagen jegliche Verformung aus Dauerlasten eliminiert, sowie eine einfache Anwendung der Plastizitätstheorie bilden die Grundgedanken.



1. THE REPERCUSSION OF OBSERVATIONS OF STRUCTURES ON THEIR DESIGN

1.1. The necessity for simplification

For some time already there have been voices raised in order to reduce the volume of checks called for in codes, standards and regulations. The vast majority of design engineers realize that only a fraction of their hundreds or thousands of pages of calculations really contribute to the good design and performance of a structure. Many of these efforts are non productive and even damaging to a sound design.

However even if a large consensus of opinion exists on the necessity of simplification of criteria and calculation leading to the design and construction of a concrete structure, it is not going to be so on the choice of simplifications. One must remark that the willingness for simplification has not, so far, led to real proposals.

Fortunately the international associations are now beginning to debate these problems. In bringing together persons of very wide background and experience in the single purpose of advancing and unifying the rules of the art of construction, they are in a better position to work in an objective fashion than certain national commissions where passions might dominate.

In order to avoid that the engineer makes meaningless checks and to allow him a simplified, but at the same time, more efficient approach to his work in the design of a structure, it is necessary to begin by making the synthesis of observation of their real behaviour. One may thus, in summarizing at least for current forms of buildings and bridges, make the following principal points :

1.2. Sources of loss of carrying capacity

The failure or collapse of a structure, or part of a structure, generally arises from an error in the design concept or construction [1]. However only marginal errors may be covered by safety factors. It follows, therefore, that in order to avoid reaching the ultimate limit state, the engineer must make further efforts towards means enabling the avoidance of errors (initial design information, organisation of design and construction, lines of communication, quality control etc.) rather than over elaborate calculations of carrying capacity. It must never be forgotten that verifications of ultimate limit states given by regulations are both abstract and conventional. It is purely by convention that such and such a load or partial safety factor is decided upon. Whilst highly scientific considerations of the probability of having so many deaths or so many thousands of francs of damage may serve as guide-lines one must be honest enough to recognize that the choice of appropriate values is, in the end, rather arbitrary. Fortunately the CEB has largely contributed in making them more uniform. Although professional ethics obliges us to carry out these checks of prescribed safety margins we must do so simply and remember that big human errors are usually at the origin of failures.

1.3. Serviceability

The serviceability or quality of use and, in consequence, the durability of structures are, in general, not affected by the live but only by the long term loading. The majority of observations show, in effect, that a short term live load on a building or traffic load on a road bridge do not alter the serviceability. Even in the extreme case of a rail bridge, where the live load is of the same magnitude as the permanent load due to concrete and ballast, a satisfactory behaviour in the permanent state may only exceptionally be altered by the loading of trains.

There are clear reasons for this. The live loads are in effect abstract values that never, or very rarely appear with the magnitude prescribed in the codes and then never in such an unfavourable position as that given by the influence lines or surfaces. The dynamic amplification factor is a value resulting from the increase of static deflections by way of the vibration of the structure. However, in the case of usual prestressed concrete structures this pseudo-amplification of loads does not introduce any harmful consequences. At the most there could be fatigue problems but they are extremely rare. One should add here the often misunderstood fact that a structure constantly loaded by a permanent load cracks much further than if it had been loaded by the same load acting momentarily. First of all the cracks take time to appear. The cracking moment of a section resulting from the tensile strength of the concrete does not increase but decreases with time to achieve about 80 % of the initial value. It is, therefore, a mistake to think if a structure has not cracked during the application of an instantaneous load that the same will hold true with time. In reality cracks take time to appear in terms of months or years and their openings increase significantly with time (see fig. 1).

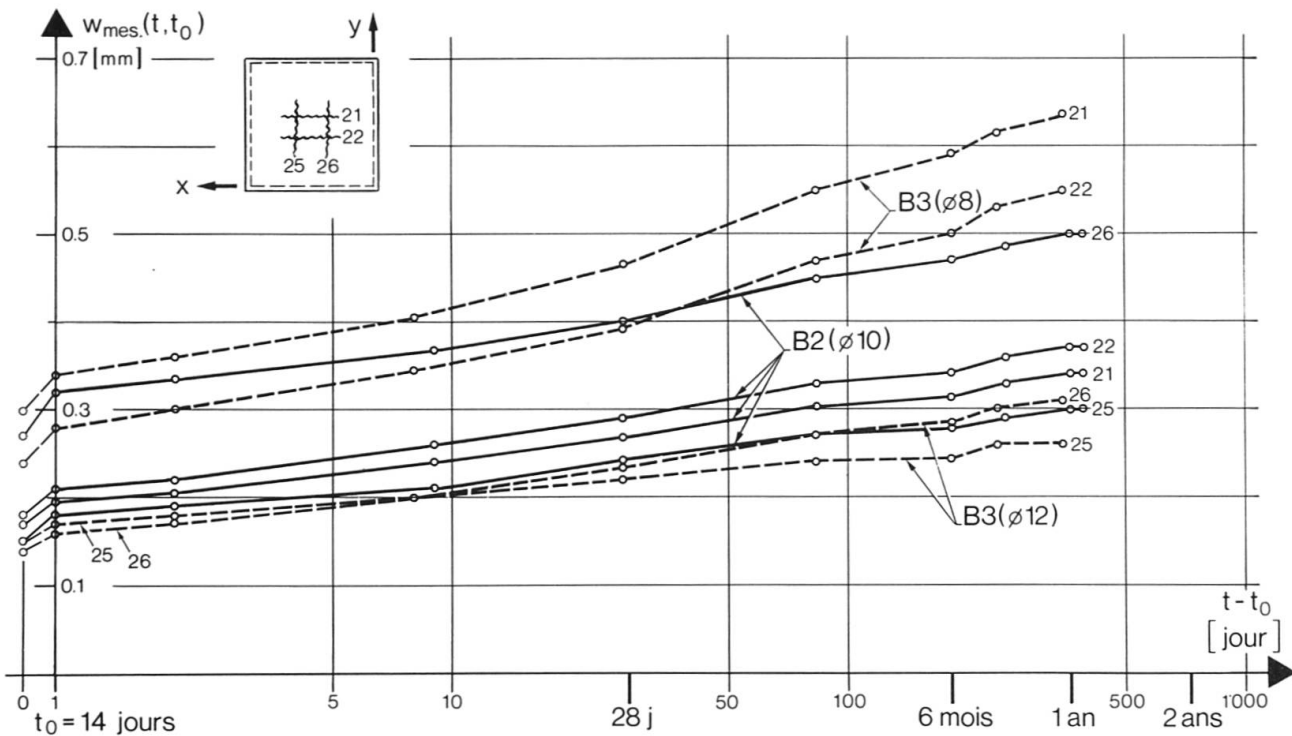

Fig. 1 - Crack growth w with respect to time measured on permanently loaded slabs [2].

2. THE DUCTIBILITY OF REINFORCED CONCRETE

There are fundamentally three possibilities for creating a structure in concrete, in so far as cracking is concerned.

- By the means of expansion joints spaced sufficiently close together, by moving bearings permitting expansion, by measures taken at construction, by a prestress etc., one is entitled to expect that the stresses in the concrete never reach the tensile strength. The structure will not therefore have any significant cracking.
- Some concentrated and important cracking is accepted from the first. Either this is neither harmful nor visible or it is later repaired by injection.
- Stresses exceeding the tensile strength are accepted but the spacing of cracks S_{rm} is controlled by means of minimum reinforcement creating ductility. This reinforcement limits the crack openings as it distributes them in a greater number. If one wishes to be more strict with respect to the mean crack opening $w_m = s_{rm} \cdot \epsilon_{sm}$, one must provide a higher degree of reinforcement based on the limitation of the mean steel strain ϵ_{sm} .

The following illustrate these possibilities .

- Take a building with balconies cantilevering out 2 m. Working on the principle of Saint-Venant one may expect that a joint in the balcony, perpendicular to the wall, will have an effect limited to a distance of 2 m either side of the joint. If, therefore, joints are placed every 4 m one may be satisfied with a light reinforcement, parallel to the wall, without risk of intermediate cracking.
- Consider the basement wall of a building with joints every 40 m. One accepts from the start important vertical cracking from restrained shrinkage which will appear perhaps every 5 m.
- In the case of a retaining wall, without joints but having a strong horizontal reinforcement little cracks will occur in a stabilised way and only visible with difficulty.

In future one will continue to make use of these three possibilities, although there is a significant trend towards the last one (c).



In the field of structures in prestressed concrete one is often tempted to believe in the first possibility. In fact this can exist for example in prestressed floor slabs of buildings, carried on moving bearings (e.g. in underground garaging) or on flexible columns (storeys of a building with a central core). Able to expand freely, sheltered from the weather and suitably prestressed these slabs run very little risk of cracking and a light passive reinforcement corresponding to 0,1 to 0,15 % of the working concrete area can be sufficient. Nevertheless care must be taken to avoid too much prestress for the permanent loads and if live load are high one will be obliged to use the third possibility.

In the case of bridges there is usually only the latter which may enter into the account. By way of the steps of construction, heat of hydration and differential shrinkage, temperature variations, stress redistribution by creep, in short all the deformations imposed on the structural system it is illusionary to believe in a total prestress where there could not be significant tensile stresses capable of attaining the concrete tensile strength.

The international trend is undoubtedly towards the third solution for many structures and bridges in particular. Clearly this signifies the necessity to provide a reasonable passive reinforcement in prestressed concrete structures in order to create a truly ductile material. The criteria necessary for the obtention of this ductility are still going to be the object of much short and long term research and testing. For the moment one must be satisfied with accepted reasoning as mentioned in § 15.2.4 of the CEB model code and take into account that the minimum reinforcement must be capable of carrying the internal force liberated by the cracking of the concrete :

$$R_s > R_r$$

with R_s : the strength of the cracked section

R_r : the strength of the homogenous section corresponding to the tensile strength of the concrete.

Accepting that the worst possible but always foreseeable internal force is pure tension then the choice of the minimum reinforcing for ductility stems from a reasoning based on a tensile element.

$$R_s = A_s \cdot f_{yk}$$

$$R_r = A_c \cdot f_{ctm}$$

with A_s : the area of the reinforcing

A_c : the cross sectional area of concrete

f_{yk} : the characteristic strength of the steel

f_{ctm} : the mean tensile strength of the concrete

Then the proportion of the minimum reinforcing ρ_{min} is obtained from the relationship :

$$R_s : A_s \cdot f_{yk} > R_r = A_c \cdot f_{ctm}$$

hence

$$\rho_{min} = \frac{A_s}{A_c} > \frac{f_{ctm}}{f_{yk}}$$

A_c represents the full concrete section for a concrete thickness ≤ 60 cm, because it is clearly the full concrete section which liberates a tensile force on cracking and if the stress thus exceeds the limit f_{yk} the reinforcement yields and creates a significant isolated crack.

We may take, by way of an example, the steel S 400 with $f_{yk} = 400$ MPa and concrete C 30 where $f_{ctm} = 2,8$ MPa. Note that f_{ctm} represents an instantaneous mean strength and that long term loading reduces it to about 80 %. To avoid reaching the yield point of the steel, we shall introduce a safety factor of $\gamma_s = 1,15$ and thus have :

$$\rho_{min} = \frac{0,8 f_{ctm}}{f_{yk}} \cdot \gamma_s = \frac{0,8 \cdot 2,8}{400} \cdot 1,15 = 0,65 \%$$

In order to illustrate this proportion of reinforcing some examples are presented in fig. 2.

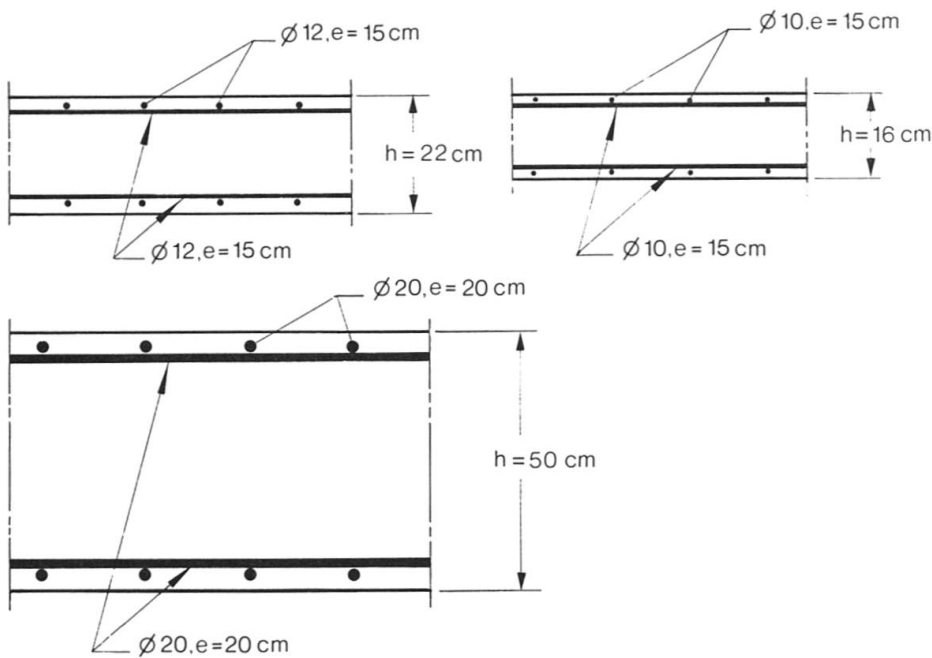

Fig. 2 - Examples of minimum reinforcing.

3. SIMPLIFIED CRITERIA FOR THE DESIGN OF PRESTRESSED CONCRETE STRUCTURES

3.1. Introduction

If we permit ourselves here to outrageously simplify design criteria it is with the view of provoking discussion and to motivate those who would like to see a more global approach to express themselves, in the international associations, by presenting real proposals. We are convinced that the following criteria lead to structures of excellent quality and that they take account of real behaviour and the observations made on structures. They enable an avoidance of many fastidious and often useless checks by clearly showing which are the important elements in a choice of dimensions. We are aware that they require more passive reinforcement and prestress. However, in so far as when they are in competition for a contract, all the tendering companies must apply the same criteria and thus will find themselves on an equal footing. The increase in cost for the client is not negligible but is generally fully compensated by economies in maintenance.

We should remember that the construction costs (without designers time, site supervision, cost of land, surveys) for a poured in situ, box section concrete bridge are roughly shared in the following manner [3]:

site installations	7 – 10 %
substructure (earthworks, abutments, foundations, piling)	20 – 33 %
superstructure	40 – 60 %
equipment and finishing	12 – 18 %

The passive reinforcing and prestress in the superstructure represents around 18 – 25 % of the total cost with the remainder being due to the falsework, shuttering and concrete.

The passive reinforcing in [3] was already high (90 - 160 kg per m^2 of deck). If in future one had to increase the passive reinforcement and prestress by 20 % this increase would only have effect on the percentage of 18 – 25 %. It would only result, therefore, in the price of the structure being increased by about 4 %.



3.2. Criteria

In addition to a study and in-depth checking to eliminate sources of errors and in order to assure a good structural behaviour during the phases of construction one may apply the following criteria for the design of prestressed concrete structures :

1st Criterion : The balancing of permanent loads :

$$a_p = -\alpha \cdot a_g$$

with a_p = midspan deflection calculated in the final system due to the mean prestress $P_m = 1/2 (P_0 + P_\infty)$

a_g = midspan deflection calculated in the final system due to all the permanent loads.

α = reduction factor, taken generally between 0,8 and 1,0.

A customer will be able to specify the value of α as he wishes. However $\alpha = 1$ is usually the best value to adopt as it indicates that the structure has no midspan deformation under permanent load and hence practically nowhere else. In addition there are neither the bending moments, M , nor the shear forces, V , from permanent loading but uniquely an axial load $N = P$. In the permanent state in order to face autostresses arising from imposed deformations (shrinkage, temperature etc.), the structure is better prepared as it is uniformly prestressed over the full height of every section. A value of $\alpha < 1$ may be appropriate when, during the prestressing operation, only a fraction of the permanent load is present or by concerns of economy.

2nd Criterion : The proportion of minimum reinforcing ρ_{min} : A customer may define a certain rate ρ_{min} valid for example for all the superstructure of a bridge. For a certain quality of concrete and steel he will be able to specify for example $\rho_{min} = 0,65\%$. In assuming a construction increase of 30 % for laps, bends, special details etc. and an orthogonal reinforcing this rate leads to the provision of reinforcing of :

$$1,30 \times 2 \times 0,65\% \times 7850 \text{ kg/m}^3 = 133 \text{ kg/m}^3$$

in the concrete. This reinforcement, which does not appear over-exaggerated, would be placed without further calculation in the structure. Only criterion 3) may lead to an increase in specific zones.

3rd Criterion : Verification of the ultimate strength : The safety check, with respect to collapse, is made by applying the plastic theory of systems either by means of the static method or the mechanism method.

As the structure is generally ductile ($x < 0,5 d$) one is permitted an arbitrary redistribution of moments. All forces arising from indirect actions, that is of deformations imposed on the system such as hyperstatic moments from prestressing, sinking of bearings, steps of construction, temperature variations, shrinkage, concrete creep and relaxation of prestressing steel do not enter into the calculation. The only forces that must be taken into consideration are those of direct actions that is to say the permanent and live loads. The simplest method is to calculate moments for a simple beam and then displace the fixing line in accordance with the resistance of the bearings (static method). For plane elements (slabs), one may apply an upper bound solution given by the mechanism method in the form of the yield line theory which is remarkable for its global approach to the resistance of an entire system.

3.3. Examples ($\alpha = 1$)

3.3.1. Bridge in the transverse sense

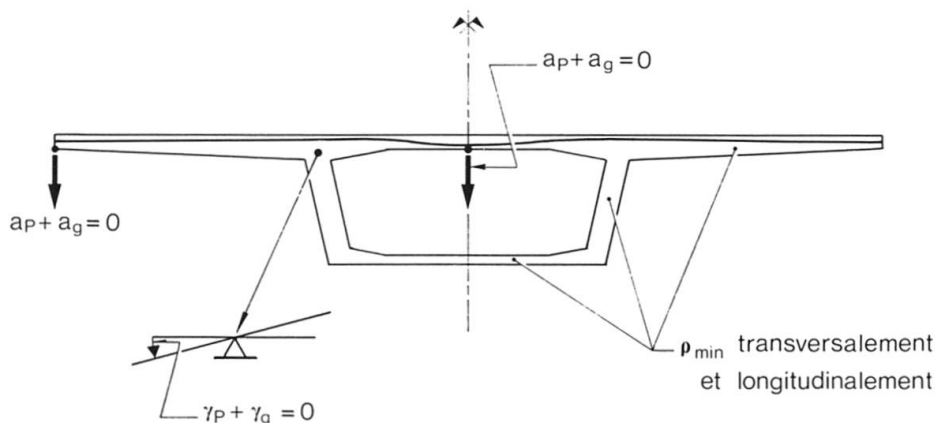

In the permanent state the deck slab does not deform vertically and therefore does not create permanent fixing moments in the webs (the effect of shortening being neglected). Verification of the passive reinforcing by means of criterion 3.

3.3.2. Bridge in the longitudinal sense

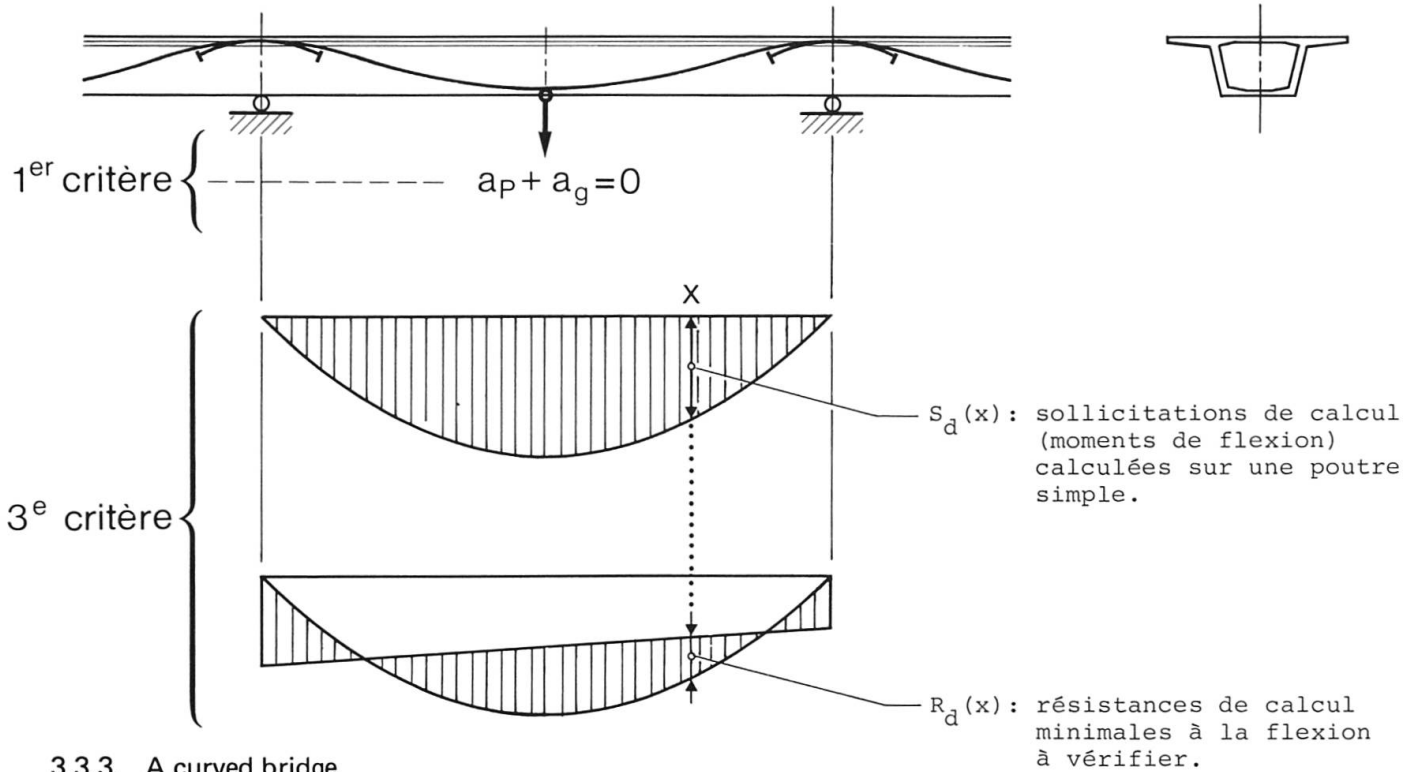

3.3.3. A curved bridge

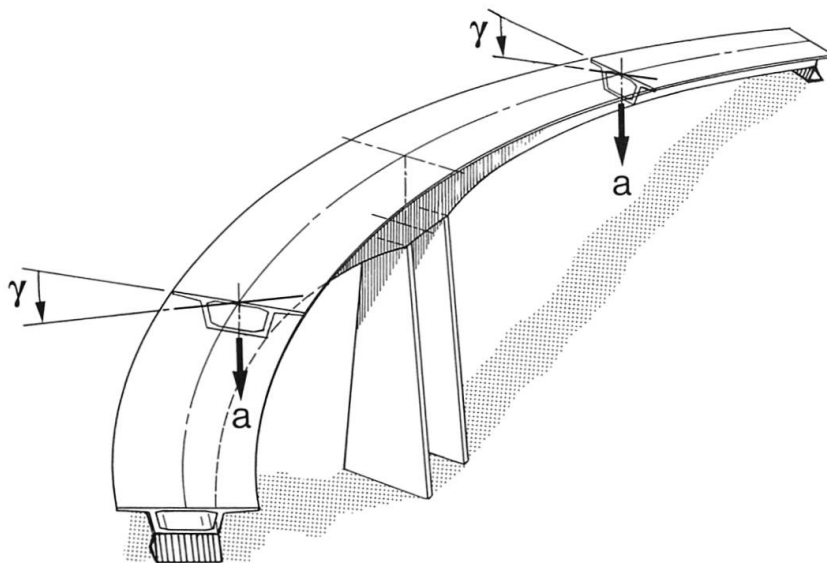

Déformation verticale $a_p + a_g = 0$

Déformation angulaire $\gamma_p + \gamma_g = 0$



3.3.4. Prestressed floor slab, g uniformly distributed

1st criterion : mid slab deflection $a_p + a_g = 0$ which may be obtained for example with the cable layout below by taking :

$$\frac{8f_1}{l_1^2} \cdot \frac{P_2}{l_2} = \frac{8f_2}{l_2^2} \cdot \frac{P_1}{l_1} = g$$

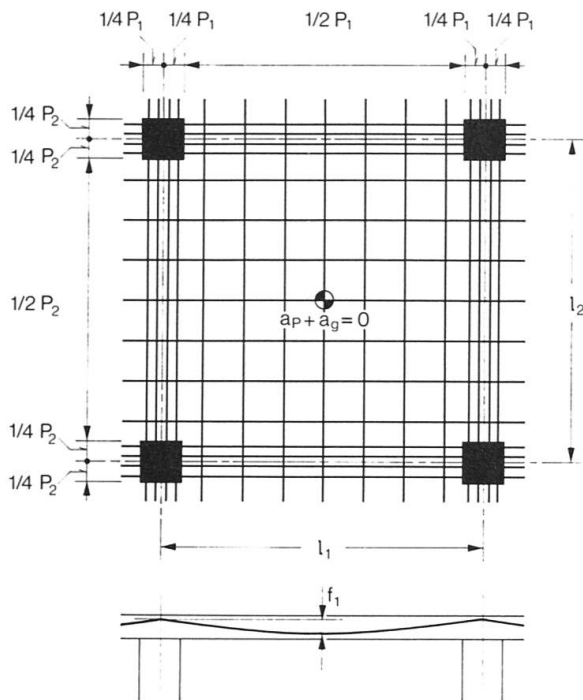

REFERENCES

1. KNOLL, F., Human Error in the Building Process – A research proposal, IABSE Journal J-17/82.
2. JACCOUD, J.-P. and FAVRE, R., Flèche des structures en béton armé, vérification expérimentale d'une méthode de calcul, Annales de l'Institut Technique du Bâtiment et des Travaux Publics, série béton 208, juillet-août 1982.
3. MENN, C., Kosten - und Massenvergleich für einige Autobahnbrücken in der Schweiz, publication "Béton précontraint en Suisse" éditée à l'occasion du congrès FIP 1982 à Stockholm.