

Zeitschrift: IABSE proceedings = Mémoires AIPC = IVBH Abhandlungen
Band: 14 (1990)
Heft: P-145: Methods of estimating the fatigue endurances of stud shear connections

Artikel: Methods of estimating the fatigue endurances of stud shear connections
Autor: Oehlers, Deric John
DOI: <https://doi.org/10.5169/seals-42837>

Nutzungsbedingungen

Die ETH-Bibliothek ist die Anbieterin der digitalisierten Zeitschriften. Sie besitzt keine Urheberrechte an den Zeitschriften und ist nicht verantwortlich für deren Inhalte. Die Rechte liegen in der Regel bei den Herausgebern beziehungsweise den externen Rechteinhabern. [Siehe Rechtliche Hinweise.](#)

Conditions d'utilisation

L'ETH Library est le fournisseur des revues numérisées. Elle ne détient aucun droit d'auteur sur les revues et n'est pas responsable de leur contenu. En règle générale, les droits sont détenus par les éditeurs ou les détenteurs de droits externes. [Voir Informations légales.](#)

Terms of use

The ETH Library is the provider of the digitised journals. It does not own any copyrights to the journals and is not responsible for their content. The rights usually lie with the publishers or the external rights holders. [See Legal notice.](#)

Download PDF: 30.01.2025

ETH-Bibliothek Zürich, E-Periodica, <https://www.e-periodica.ch>

Methods of Estimating the Fatigue Endurances of Stud Shear Connections

Méthodes d'estimation de la résistance à la fatigue de goujons

Abschätzung der Ermüdungsfestigkeit von Kopfbolzenverbindungen

Deric John OEHLERS

Senior Lecturer
University of Adelaide
Adelaide, Australia



Deric Oehlers is a graduate from the University of London. After seven years in industry he obtained his Ph.D. at the University of Warwick where he began research into composite structures.

SUMMARY

Methods of estimating the fatigue endurances of stud shear connections in composite bridge beams have been derived from the analysis of two hundred and eighty push tests. It was found that the range of the cyclic shear load, the maximum applied shear load and the static strength of the connection significantly affected the fatigue endurance of stud shear connectors. Guidelines are given for determining the strength and endurance of shear connections in composite beams from tests on shear connections in push specimens.

RÉSUMÉ

L'analyse de nombreux essais au cisaillement a permis de développer une méthode d'estimation de la résistance à la fatigue de goujons dans des poutres de ponts mixtes. La recherche a montré que la variation de la charge cyclique de cisaillement, la charge maximum appliquée et la résistance du connecteur ont une influence déterminante sur la résistance à la fatigue des goujons. L'auteur propose des directives pour la détermination de la résistance et de l'endurance des goujons dans des poutres composites.

ZUSAMMENFASSUNG

In Auswertung von zahlreichen Abscherversuchen an Kopfbolzenverbindungen, von Verbundbrückenträgern, wurden Methoden entwickelt, um deren Ermüdungsfestigkeit abzuschätzen. Es zeigte sich ein deutlicher Einfluss der Amplitude der Wechselschublast, der maximalen Schubbelastung und der statischen Festigkeit der Verbindung. Der Beitrag gibt Richtlinien zur Bestimmung der statischen Festigkeit und der Dauerfestigkeit von Schubverbindungen in Verbundträgern aus Tests der Verbindungen in Abscherprobekörpern.

1. INTRODUCTION

The fatigue endurances of stud shear connectors in composite beams are usually derived from push tests. The results from these push tests vary widely because of the different sizes and shapes of the push specimens, because of the variation in the number and positions of the studs, because of the various restraints that are applied to the specimens, and because of the various failure modes that can occur in push tests. The prediction equations that have been derived from these tests take various forms which depend on the choice of parameters that are assumed to control the endurance; furthermore, the form of these equations depends on whether connectors are assumed to fail in groups or individually. As these uncertainties have led to very wide differences between prediction endurance equations, the results on which they were based have been reanalysed as a whole in order to determine the best form and magnitude of a prediction equation for use with stud connectors in composite bridge beams.

The design of the shear connectors in composite steel and concrete bridge beams is generally based on the static and fatigue strengths of connectors in push tests, as the shear forces on the connections in push tests can be measured directly. However, the behaviour of connectors in push tests is not a good representation of the behaviour in composite beams because of the difference in the external restraints between the two systems[1]. Furthermore, large variations occur between the restraints on push specimens, as shown in Figs. 1-4, so that the

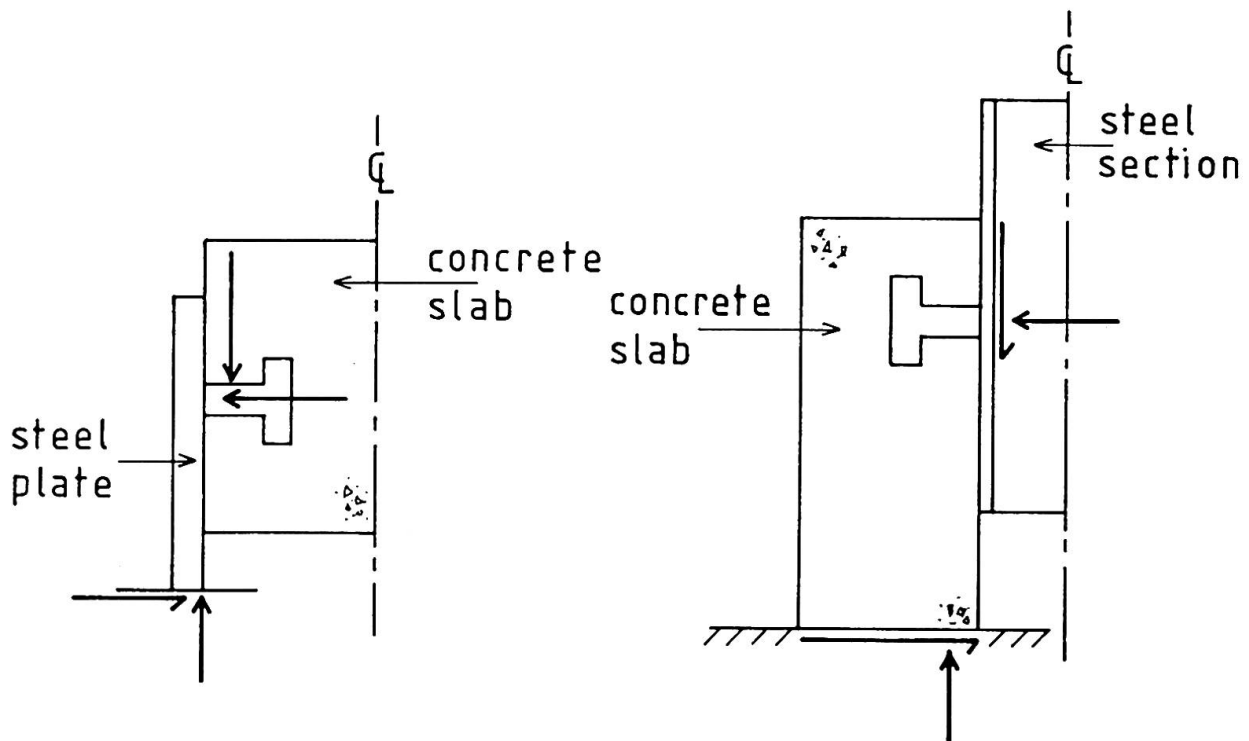

Fig. 1 Lo's push specimen.

Fig. 2 Standard push specimen.

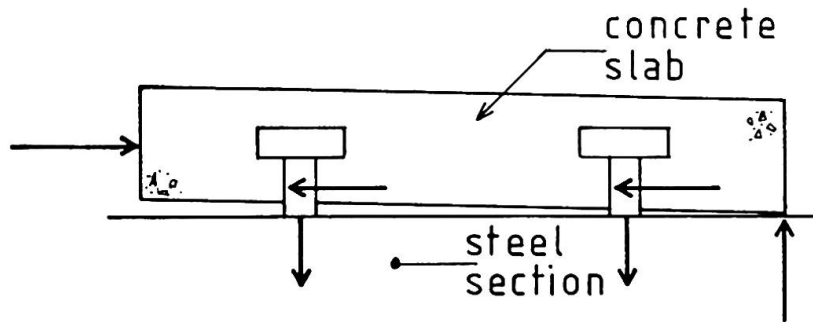

Fig. 3 Slutter & Fisher's push specimen.

endurances derived from push tests tend to have large variances between test series as well as the large variance due to 'experimental error' which is normally associated with fatigue tests. The scatter of results is further increased due to the fact that stud shear connectors can fail in five modes: dowel failure of the stud; failure of the steel flange adjacent to the stud; and shear, embedment or splitting failure of the concrete slab. This scatter is further compounded by the fact that present design techniques assume that different parameters affect the fatigue endurance.

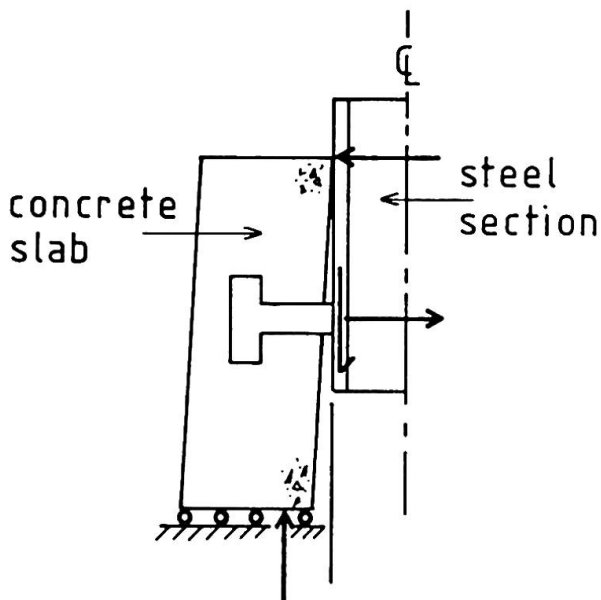

Fig. 4 Mainstone & Menzie's push specimen.

The scatter of results, the effect of the external restraints and the parameters that affect the endurance are determined in the following analysis of two hundred and eighty push tests. In this analysis, those specimens which may have failed by a mode other than dowel action were omitted from the statistical population, as it is suggested that the other failure modes can be designed against by good detailing. This research is therefore based on fatigue dowel failure, an example of which is shown in Fig. 5 where it can be seen that there is little damage to the concrete except in a zone immediately adjacent to the stud and that the stud itself shows distinct zones of fatigue cracking (the dull region) and rapid crack formation (the bright region). It was found that the range of the cyclic shear load, the maximum applied shear load and the static strength of the connectors significantly affected their endurances.

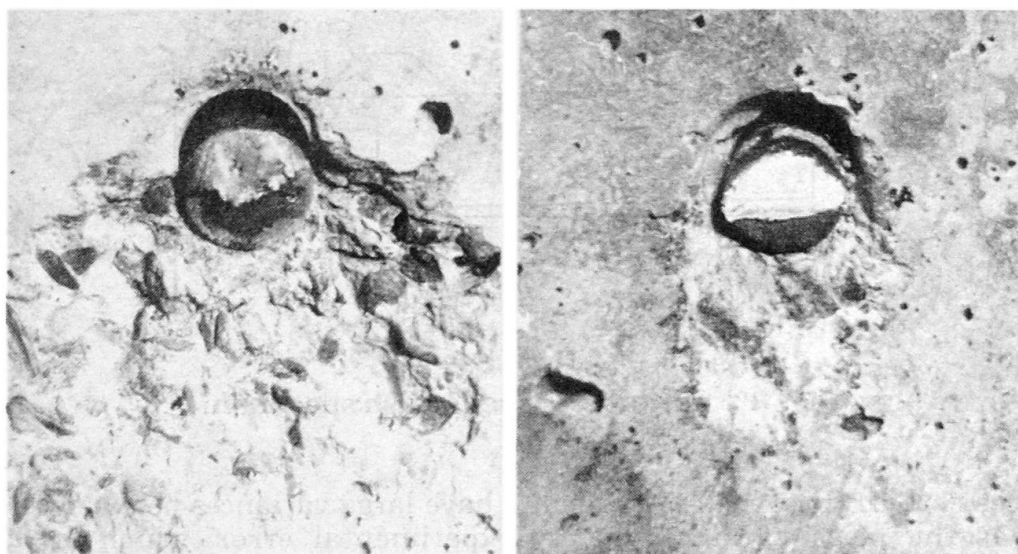

Fig. 5 Dowel failure of stud shear connectors.

2. PUSH TESTS

The data from two hundred and eighty push tests have been collected from research in the United States[2], the United Kingdom[3-6], Ireland[7], Australia[8-10], and Japan[11]. One hundred and twenty-four of these results were omitted from the following statistical analyses for one of the following reasons: the studs had not completely fractured at the end of the test; the full load history up to monotonic failure was not recorded; embedment, shear or splitting failure of the concrete slab may have occurred; the studs were stated to be badly welded; the studs were concreted in an inverted position which led to bad compaction at the base of the stud; fatigue failure occurred through the depth of the steel flange; and reverse cyclic loading had been applied. The statistics of the remaining one hundred and fifty-six results are given in Ref. 12. The push specimens used in these tests can be categorized into two types; those in which the external restraints induced a resultant compressive force across the steel-flange/concrete-slab interface as in Figs. 1 and 2, and those in which the resultant force is zero as in Figs. 3 and 4. In Maeda's tests, the static strengths of the connections in the push tests were determined experimentally, and in the other tests they were derived from a prediction equation[1] which was based on an analysis of one hundred and ten push tests, and which allowed for the number and position of the studs in the push tests and for the difference between the strengths of studs in push specimens and in composite beams. The data that is used in the following statistical analyses, full details of which are given in Ref 12, has the following range of variables: $1.4E4 < N_e < 2.4E7$; $25 < f_c < 70$ (N/mm²); $8 < R < 71$ (kN); $20 < P < 103$ (kN); $62 < F < 183$ (kN). All the specimens were subjected to constant unidirectional cyclic loads.

3. ANALYSIS OF PUSH TEST RESULTS

3.1 PARAMETRIC STUDY

The dependence of the endurance N_e on the four independent variables in the following equation was determined by subjecting the experimental results to multi-variable linear regression analyses of the logarithms of the variables.

$$N_e = f(A, R, f_c, P) \quad (1)$$

The variables were brought into the analysis in the sequence shown in Eqn. 1. The following results of the analysis with the first two variables is a prediction equation that is equivalent to the method used in the European Code[13], in which the endurance depends on the range of shear stress in the stud R/A .

$$N_e = 7.1 A^{4.1} R^{-3.4} \quad (2)$$

HS HS

$$\text{COV} = 9.1\% \ \& \ \text{SD} = 0.50$$

The significance of each variable was determined by considering the probability of the exponent of the variable being zero; in this case, both variables are highly significant HS i.e. the probability of the exponent being zero is less than 0.0001. As expected, the endurance is directly proportional to the cross-sectional area of the stud and inversely proportional to the range of the cyclic load. The standard deviation SD and the coefficient of variation COV are in terms of $\log_{10} N_e$. Including the cube strength of the concrete f_c gave the following results.

$$N_e = 0.44 \times 10^{-3} A^{4.8} R^{-3.8} f_c^{1.9} \quad (3)$$

HS HS HS

$$\text{COV} = 8.6\% \ \& \ \text{SD} = 0.48$$

The dependence of the endurance on f_c is in agreement with observations by Roik[14]. The high significance of A and f_c would suggest that the endurance depends on the static strength of the connectors. The following inclusion of the peak of the cyclic load P further reduces the scatter.

$$N_e = 0.27 \times 10^{-3} A^{5.2} R^{-3.1} f_c^{2.2} P^{-1.2} \quad (4)$$

HS HS HS S

$$\text{COV} = 8.4\% \ \& \ \text{SD} = 0.47$$

In this case the peak load is significant i.e. the probability of the exponent being zero lies between 0.01 and 0.0001 and the endurance is inversely proportional to the peak of the cyclic load.

The effect of the static dowel strength was determined by assuming that the endurance is a function of the strength that the connections would have had in



monotonic push tests[1], as well as being a function of the range and peak of the cyclic load. This gave the following results.

$$N_e = 0.63 F_p^{6.2} R^{-4.8} \quad (5)$$

HS HS

$$\text{COV} = 7.5\% \text{ \& } \text{SD} = 0.42$$

$$N_e = 1.25 F_p^{6.6} R^{-4.1} P^{-1.3} \quad (6)$$

HS HS HS

$$\text{COV} = 7.2\% \text{ \& } \text{SD} = 0.40$$

which further confirms the significance of the static strength on the endurance.

In Eqn. 6, the modulus of the sum of the exponents of R and P is close to the exponent of F_p ; this would suggest that N_e is a function of the parameters R/F_p and P/F_p . An analysis of this function gave the following results.

$$N_e = 800 (R/F_p)^{-4.6} \quad (7)$$

HS

$$\text{COV} = 7.9\% \text{ \& } \text{SD} = 0.44$$

$$N_e = 400 (R/F_p)^{-3.9} (P/F_p)^{-1.6} \quad (8)$$

HS HS

$$\text{COV} = 7.5\% \text{ \& } \text{SD} = 0.41$$

Equation 8 is an improvement over Eqn. 4 as the coefficient of variation is 11.5% lower, the number of independent variables has been reduced from four to two, and Eqn 8 is dimensionally correct whereas Eqn. 4 is dimensionally incorrect.

3.2 PREDICTION EQUATIONS

Equation 7 represents the method used in the British Code[15]. The following result of a parallel regression analysis of the variables used in deriving Eqn. 7 (a technique described in Ref. 16), gives a better estimate of the exponent, as it ignores the variance between series and hence the variation between external restraints, with only a small increase in the scatter.

$$N_e = 287 (R/F_p)^{-5.4} \quad (9)$$

$$\text{COV} = 8.1\%, \text{ SD} = 0.45 \text{ \& } \text{SD}_e = 0.35$$

where SD_e is the best estimate of the standard deviation due to the experimental error, as derived from each series of tests. The difference between SD and SD_e is due to the variance between series of tests which is caused by the variation in the external restraints between series of tests. Equation 9 is compared with the experimental results in Fig. 6 and its characteristic strength at 2SD is also shown.

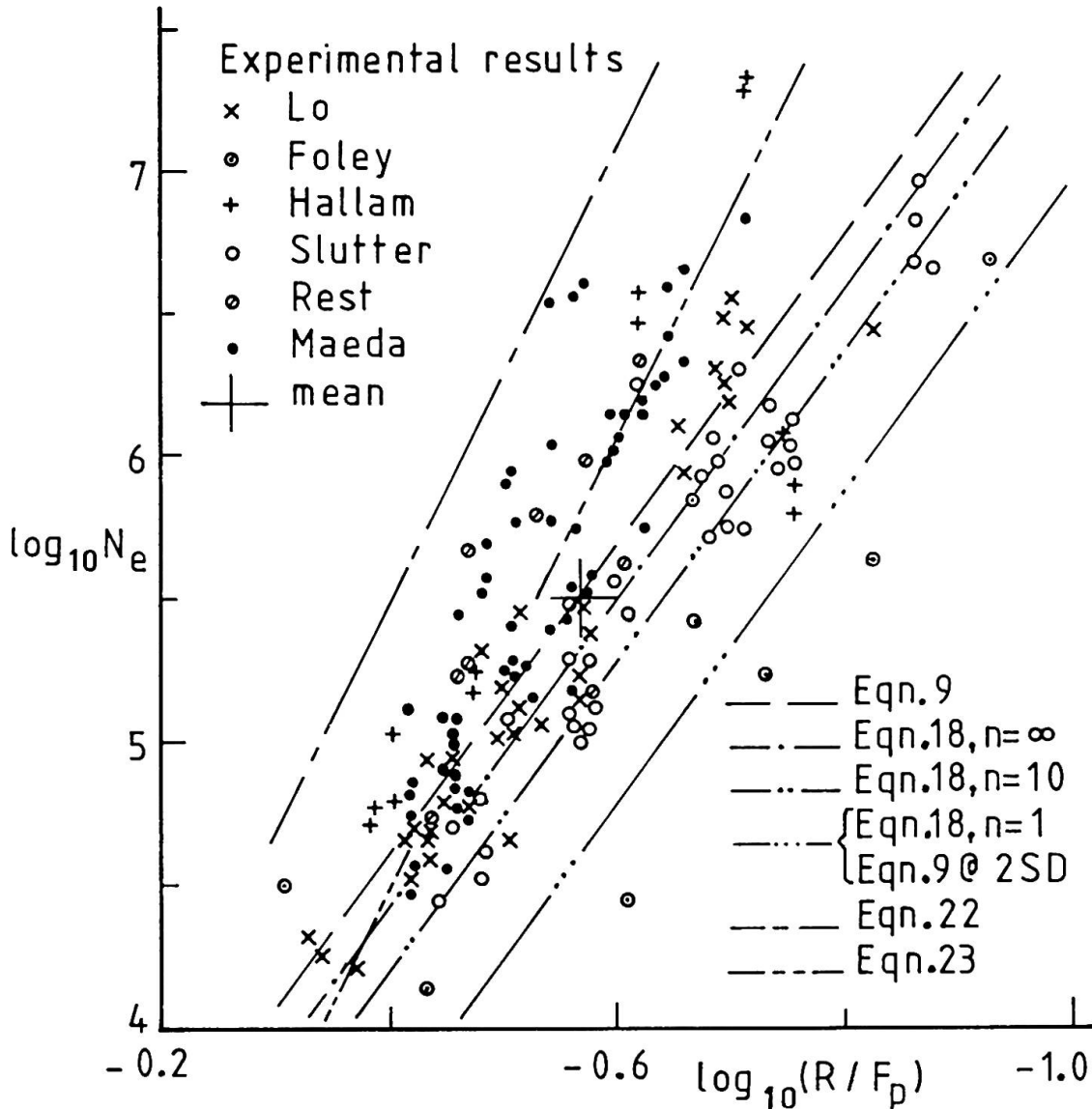

Fig. 6 Endurance as a function of the static strength

The modulus of the exponent of P/F_p in Eqn. 8 is reasonably close to unity to suggest that the following linear relationship [17] between N_e and P/F_p may be sufficiently accurate for design purposes.

$$N_f = N_e / (1 - P/F_p) = f(R/F_p) \quad (10)$$

A statistical analysis using the above function gave the following results.

$$N_f = 1660 (R/F_p)^{-4.4} \quad (11)$$

HS

$$\text{COV} = 7.4\% \text{ and } \text{SD} = 0.42$$

The coefficient of variation is slightly less than in Eqn. 8 and the endurance is now in terms of one independent variable.



The following result from a parallel regression analysis gives a more accurate estimate of the exponent with only a very slight increase in the scatter.

$$N_f = 670 (R/F_p)^{-5.1} \quad (12)$$

HS

$$\text{COV} = 7.5\%, \text{SD} = 0.43 \text{ \& } \text{SD}_e = 0.35$$

Equation 12 and its characteristic strengths are compared with the experimental results in Fig. 7. The results of the parallel regression analyses through the arithmetic means of each major series of tests are shown in Fig. 8, where it can be seen that the endurance of Maeda's specimens are four times those of Foley's. This variation between the series is due to the forces induced on the connections by the external restraints that are applied to the push tests. The results of an analysis based on the shear stress R/A , as used in the European Code [13] is given below.

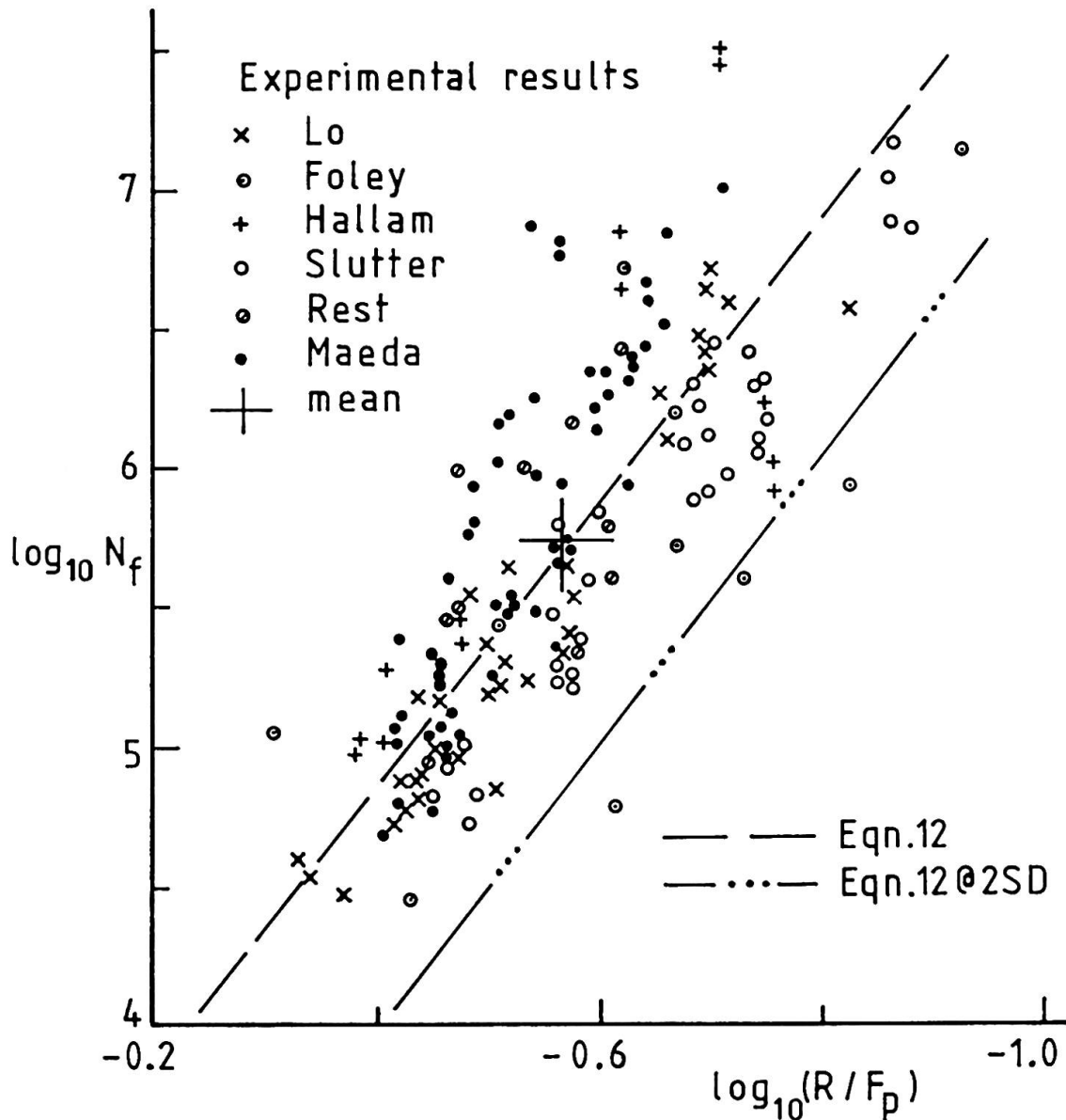

Fig 7 Endurance as a function of the maximum load

$$N_e = 0.89 \times 10^{13} (R/A)^{-3.5} \quad (13)$$

HS

$$\text{COV} = 9.0\% \quad \& \quad \text{SD} = 0.50$$

A parallel regression analysis gave the following results.

$$N_e = 2.09 \times 10^{16} (R/A)^{-5.1} \quad (14)$$

HS

$$\text{COV} = 10.0\%, \quad \text{SD} = 0.55 \quad \& \quad \text{SD}_e = 0.37$$

The overall scatter of this method is much greater than in the two alternative methods given in Eqns. 9 & 12. Equation 14 and its characteristic strength are compared with the experimental results in Fig. 9.

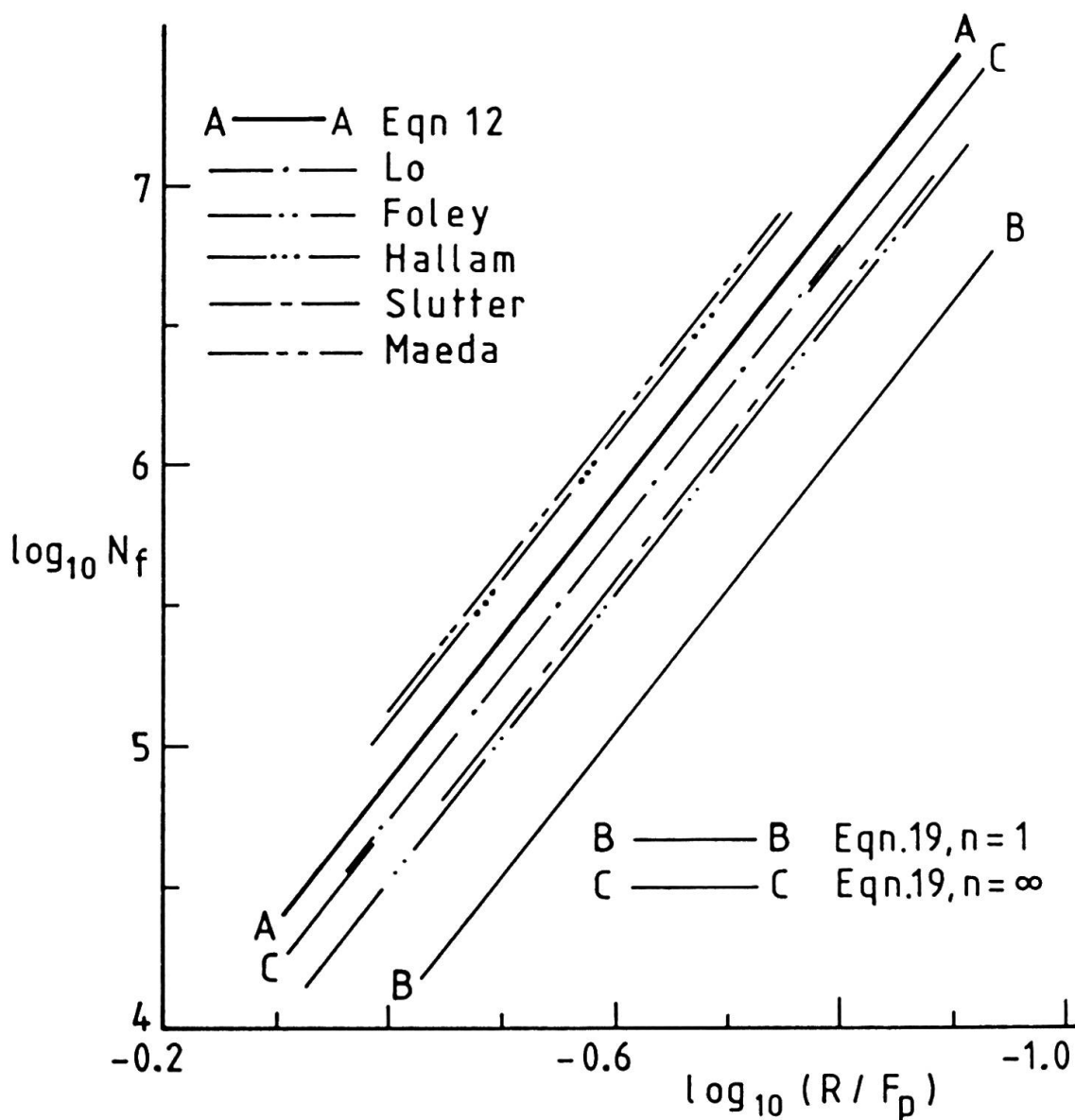

Fig. 8 Parallel regression analysis



The exponents from the different methods of analysis are listed in the first three columns of Table 1; from analyses with all the results, rows 1-2, and from analyses of the five major series of tests, rows 3-7. The exponent varies from 3.90 to 7.28 when each series of tests is considered separately (rows 3-7), this range reduces when all the results are included (rows 1-2) and the exponent then varies from 5.09 to 5.42 in the parallel regression analyses.

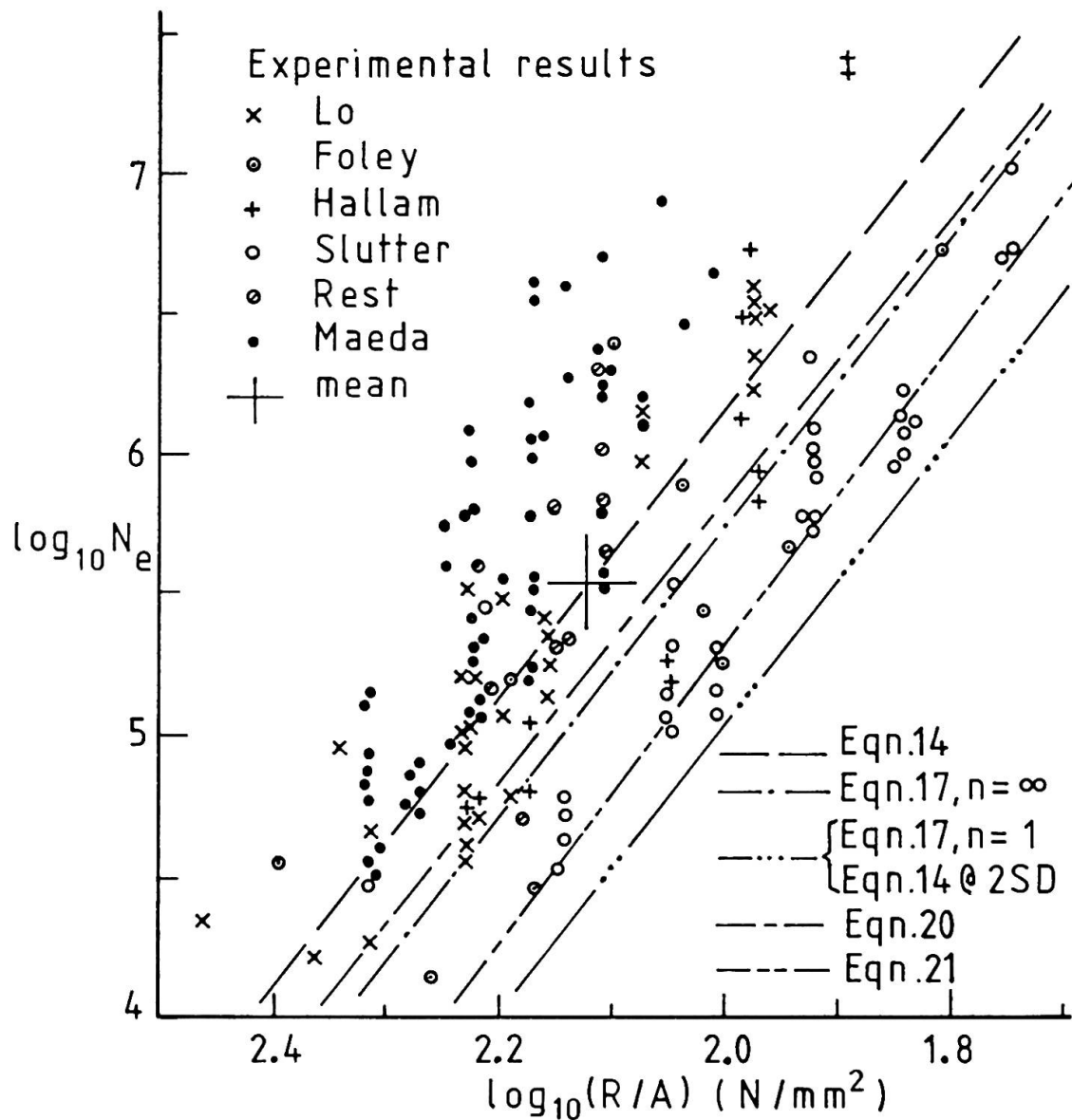

Fig. 9 Endurance as a function of the shear stress

TABLE 1. EXPONENT OF FATIGUE PREDICTION EQUATION

Reference (No. of results)	Exponent (-m)		
	$N_e = f(R/F_p)$	$N_f = f(R/F_p)$	$N_e = f(R/A)$
All[2-11] (156)	4.63	4.41	3.51
All[2-11] (parallel regression)	5.42	5.10	5.09
Lo[9] (34)	5.75	5.34	5.27
Foley[7] (10)	3.43	3.30	3.90
Hallam[8] (13)	4.86	4.45	7.17
Slutter[2] (32)	5.43	5.21	4.32
Maeda[11] (57)	7.28	6.83	6.57

4. DESIGN METHOD

The differences between the parallel regression analyses in Fig. 8 are mainly due to the variation between the external restraints that are applied to the push tests; these restraints are shown in Figs. 1-4.

When the base is fully restrained as in Figs. 1 & 2, the tendency to splay outwards induces frictional forces at the base which result in a compressive force through the steel/concrete interface and through the stud. Both of these resulting compressive forces increase the endurance of the push specimen; the compressive force in the stud increases its static strength[1] and hence endurance, and the force across the interface allows part of the shear force to be resisted by the friction across the interface and hence reduces the range of load on the connector. The effect on the endurance of the friction force across the interface is shown in the following equation.

$$N_e = 10^k(R/F_p)^{-m} (1-k)^{-m} \quad (15)$$

where k is the proportion of applied range of load that is resisted by friction. Hence friction does not affect the slope of the prediction equation but increases its magnitude.



When the base is not restrained, as in Figs. 3 & 4, then the total force across the interface is zero. Then the beneficial effect on the endurance of the shear that is transferred by friction is offset by the detrimental effect of the axial tensile loads on the connectors which reduce its static strength [1].

The stud shear connectors in composite bridge beams are not subjected to the same external restraints as those in push tests; there is a compressive force across the concrete/steel interface, but the shear transferred through this force can be shown to be very small when compared with the shear strength of the connectors. Therefore, in the design of beams, it can be assumed, with little conservatism, that there is no force across the interface and therefore the design equation should probably lie within the range of the experimental results shown in Fig. 8, i.e. below Maeda's, in which the base was restrained, and above Slutter's where there was little or no restraint. As the position within the range is not known, a design equation derived from the following lower bound procedure, which is based on present design philosophies, is proposed.

4.1 CHARACTERISTIC DESIGN STRENGTH

Considering Fig. 8, the mean for all the results (line A-A) is known accurately as well as the characteristic value for a single test at 2SD (line BB). It is this latter value which is normally used in design and which is taken to be the characteristic strength of an individual connection. Experimental research has shown that the static strength of stud shear connectors can be based on the characteristic strength of a group of connectors[1] because of a plastic plateau near failure, and furthermore the fatigue endurance can also be based on group failures because of the incremental slip which redistributes the shear load from weaker to stronger connectors[18]. Therefore, it is suggested that a more accurate allowance for reliability should be based on the characteristic endurance of groups of n connectors in which similar displacements occur, and not on the characteristic endurance of an individual connector, and hence the constant in the endurance equation should be a function of n .

The following 'lower bound' form of a design equation for the characteristic strength of a group of n connectors at two standard deviations is proposed.

$$\log_{10}N_d = \log_{10}N_e - 2(SD - SD_e) - 2 SD_e / \sqrt{n} \quad (16)$$

This prediction equation is used as : it has the same characteristic strength at $n = 1$ as in present design methods (such as line B-B in Fig. 8); the strength at $n = \infty$ (line C-C) is a lower bound to the mean strength from all the results; and furthermore the characteristic strength is based on the experimental error SD_e which is known accurately i.e. it does not include the variance between series. Prediction equations 9, 12 & 14 have been rearranged into the form of Eqn. 16 to give the following characteristic design strengths.

European Code method:

$$N_d = 10^K (R/A)^{-5.1} \quad (17)$$

$$\text{where } K = 15.922 - 0.704 / \sqrt{n}$$

and the shear stress is measured in N/mm^2

British Code Method:

$$N_d = 10^K (R/F_p)^{-5.4} \quad (18)$$

$$\text{where } K = 2.270 - 0.704 / \sqrt{n}$$

Maximum Load method:

$$N_d = 10^K (R/F_p)^{-5.1} (1 - P/F_p) \quad (19)$$

$$\text{where } K = 2.675 - 0.704 / \sqrt{n}$$

4.2 EXISTING DESIGN TECHNIQUES

The characteristic design strengths of Eqns. 17-19 are compared with the following existing design techniques in Figs. 6 and 9.

Eurocode[13] characteristic endurance:

$$N_e = 6.55 \times 10^{15} (R/A)^{-5} \quad (20)$$

$$\text{where the stress is measured in } N/mm^2$$

Slutter and Fisher[2] mean endurance :

$$N_e = 8.08 \times 10^{15} (R/A)^{-5.3} \quad (21)$$

$$\text{where the stress is measured in } N/mm^2$$

BS5400¹⁵ mean endurance :

$$N_e = 200 (R/F_p)^{-8} \quad (22)$$

BS5400¹⁵ characteristic endurance :

$$N_e = 19.5 (R/F_p)^{-8} \quad (23)$$

There is reasonable agreement with the European Code (Eqn. 21) and Slutter's method (Eqn. 22) in Fig. 9 and little agreement with the British Code (Eqn. 23) in Fig. 6. However, as suggested by Johnson [19], the total design package in Codes can only be compared. It is difficult to compare the individual techniques directly as they are often based on different parameters and even when the parameters are the same, the variables within the parameters are often derived using different techniques; an example of which is the parameter R/F_p where the value of the variable F_p varies according to the Code of Practice being used.

5. APPLICATION TO COMPOSITE BEAMS

There was a deliberate attempt in the above analysis to bring in as few assumptions as possible, and hence no quantitative allowance was made for the different types of push specimens. The design rules in Eqns. 17-19 were therefore derived using assumptions similar to those that have been used in the derivation of existing design rules and they could, therefore, be used to replace them. Eqns. 17-19 can be considered to be theoretically more accurate than existing design rules as they were derived from a much larger population and from specimens which only failed under dowel action.



The wide variation between each series of results, as shown in Figs.6-9, suggest that the fatigue lives of stud shear connectors depends on the type of push specimen. Furthermore, designers are not directly interested in the endurance of stud shear connectors in push tests but require the endurance of the shear connectors in composite bridge beams. A solution to these two problems can be determined from: a fundamental understanding of the dowel action of stud shear connectors; how this is affected by the various external restraints applied to push tests as shown in Figs.1-4; and how these restraints compare with those within composite beams. This problem is discussed in qualitative terms below and leads to a technique that uses push tests to determine the fatigue lives of shear connectors in composite bridge beams.

Consider the case of a shear connector that is cast into a concrete slab that has been designed not to fail due to splitting, shear or embedment failure. As a shear connector is simply a steel dowel that is embedded in a concrete medium, there are certain fundamental behaviours which are independent of the shape of the steel dowel. These behaviours [17] can be explained in qualitative terms by considering the elastic behaviour of a steel dowel, of fixed shape and size and yield strength f_y that is embedded in concrete of various stiffnesses, Fig.10.

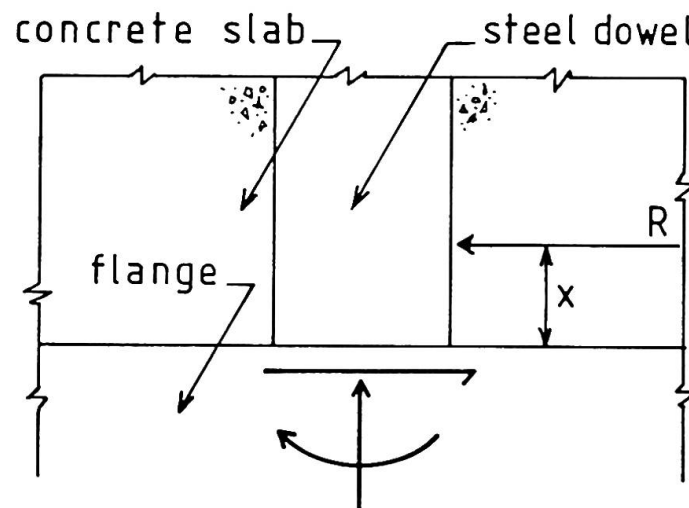

Fig. 10 Dowel Action

Applying a shear force to the shear connection in Fig.10, will induce a resultant force R across the steel/concrete interface at a distance x from the flange. This stress resultant will induce a shear force and moment at the base of the connector. Failure can be assumed to occur, in this hypothesis, when this combination of stress resultants causes f_y to be reached in the steel dowel. If the same dowel is embedded in concrete with a lower material stiffness, then the position of the resultant x will increase [1] and therefore the same shear load will induce a larger flexural stress at the base of the steel dowel and hence failure, at yield f_y , will be reached at a lower shear load. Both connectors therefore fail when f_y is reached but they fail at different shear loads which depends on the material stiffness of the concrete. This explains why increasing the strength and stiffness of the concrete surrounding the steel dowel increases the shear strength of the shear connector, as has been shown experimentally [1]. Fatigue damage in a steel section is governed by the range of stress in the steel, therefore shear connectors which are subjected to

the same R/F_p will be subjected to the same range of stress in the steel dowel and therefore would be expected to have the same fatigue endurance.

The variation in the external restraints, as shown in Figs.1-4, varies the axial forces in the steel dowel. This induces an axial stress which affects the shear force to cause monotonic failure [1]. Therefore different push-specimen geometries will cause variations in the shear strength of the connectors because of the variation in the external restraints and hence axial loads. However, even though the static strengths vary between push specimens with the same steel dowel and concrete properties, failure will occur in all cases when f_y is reached. Therefore the same range of stress can be applied to the steel dowel by applying the same R/F_p where F_p is the static strength of the shear connector in the push specimen.

The variations in the shape of the push specimens, in the external restraints to the specimens, in the size and shape of the steel dowels, in the number and position of the steel dowels within the concrete slab, and in the properties of the concrete are therefore allowed for when the range of shear load R is taken as a proportion of F_p . The scatter between series of tests can therefore be eliminated if the parameter R/F_p is used in analysing the endurance. It is therefore a question of determining experimentally the static dowel strength of the connectors in a push specimen. Very rarely has the static strength been determined experimentally for a series of fatigue tests. The one exception is by Maeda and Matsui [11] in which they tested 19mm diameter studs in concrete which varied in strength from 35 to 52 N/mm². The author has just completed a series of fatigue tests at the University of Adelaide which used 13mm diameter studs embedded in concrete of strength 60 N/mm² and in which the static strength was also determined experimentally (part of the results are given in Ref.20). By comparing the endurance as a function of R/F_p , the Adelaide results were found to be in very close agreement with Maeda's results; this confirms that the parameter R/F_p removes the scatter between series even though the above hypothesis is based on an elastic analysis and the real situation is much more complex. The external restraints that are induced in push tests do not occur in composite beams, so in order to apply the endurance that were derived from shear connectors in push tests to those in composite beams a correlation between the two systems has to be determined.

The main difference between the two systems is the normal force across the steel-flange/concrete-slab interface which can be assumed to be zero in composite beams [1]. The strength of shear connectors in composite beams can therefore be considered to be the same as the strength of shear connectors in push tests in which the external restraints induce zero axial load in the steel dowel F_b . This strength can be found from testing push specimens in which the axial loads can be measured directly [1], an example of which is shown in Fig.11. The reaction B in Fig.11 can be moved laterally to cause axial tensile or compressive forces T and hence the shear strength at zero axial load can be determined. This has already been done for stud shear connectors [1] and has led to the following design equation:

$$F_b = 4.1 f_u A (E_c/E_s)^{0.40} (f_c/f_u)^{0.35} \quad (24)$$

where f_u is the tensile strength of the stud material and E_c and E_s are the moduli of the concrete and stud steel; the latter can be taken as 206 kN/mm².

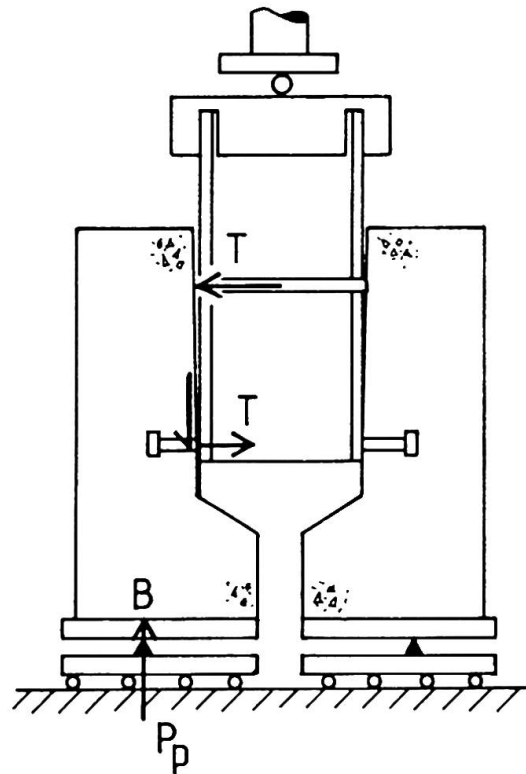

Fig. 11 Test rig for applying axial and shear loads

The endurance of the shear connectors in composite beams can therefore be derived from research that uses push tests. For example, Eqns.18&19 can be used to derive the endurance of stud shear connectors in beams by simply substituting the static strength of the stud shear connector in a composite beam (F_b in Eqn.24) for the static strength of the shear connector in the push test F_p .

5.1 GUIDELINES FOR DETERMINING ENDURANCE IN COMPOSITE BEAMS

Push tests are a simple and cheap method of directly determining the monotonic and fatigue strengths of shear connectors and therefore their use should be encouraged to allow the continual development of shear connections. The shape of push specimens and the external restraints that are applied to them vary throughout the world and this has led to wide variations in the experimentally measured endurances and strengths. However it is not necessary to standardise push specimens in terms of size, shape or restraints in order to determine the strength and endurance of shear connections in a composite beams. What is necessary, is to standardise the method of designing push specimens and to standardise the testing procedure; examples of which are given below.

Design of Push Specimen

The size and shape of the concrete slab, the reinforcing bars within the concrete slab, the number and position of the steel dowels within the slab, the steel section to which the dowels are welded and the restraints that are applied to the push specimens can all affect the shear strength of the connector. Each aspect is discussed below.

Concrete slab: Any shape of concrete slab can be used. However it is necessary to ensure that the concrete slab does not fail before the dowel strength of the shear connection is reached. There are three basic tensile failure modes by which the concrete slab can fail: splitting, which forms a tensile crack along the line of thrust of the connector and which is caused by the lateral dispersal of the concentrated dowel force; shear failure, which induces a herringbone formation of cracks which are inclined to the direction of thrust; and embedment failure of the concrete slab which is often associated with a cone of concrete being pulled out of the slab.

The most common form of slab failure is splitting because push specimen slabs are normally narrower than the slabs in composite beams. A method has been derived [21] for determining the load at which the concrete slab in push tests or in composite beams split. This method allows for combinations of shear connectors and can be used to design the concrete slab against splitting.

Shear failure of the concrete slab rarely occurs in push specimens as this failure mode is normally associated with lines of connectors. The steel dowel of most shear connectors are designed so that they do not pull out of the slab and therefore embedment failure also rarely occurs. So in general, shear and embedment failure can be ignored in designing the concrete slab in push tests.

Reinforcing bars: As the concrete slab is designed not to fail under tensile strength when subjected to concentrated dowel forces, there is no structural need for reinforcing bars.

The author usually places nominal longitudinal and transverse reinforcement in the top and bottom of the slab for handling purposes. Alternatively, the designer may wish to use the minimum requirement in the national code of practice or the reinforcement layout to be used in the composite beam. However, it is very important that the reinforcement is not placed close to the base of the steel dowel i.e. within the very localised concrete compressive failure zone which is always associated with dowel action [22]. Otherwise the dowel strength may be increased above that of the strength of the dowel in the composite beam. It is suggested that, in the case of stud shear connectors, the reinforcing bars should be placed more than three or four stud diameters from the base of the stud; equivalent values can be used for other types of shear connectors.

Steel dowels: There are several criteria for arranging the shear connectors within the push specimen. These criteria are required to prevent premature failure of the concrete slab, to minimise the scatter of results, and to determine the true mean strength.

As discussed in the design of the concrete slab, the steel dowels should be arranged so that the resulting concentrated dowel forces do not cause tensile failure of the concrete slab. Furthermore, the connectors should not be placed so closely together



that the concrete compression failure zones, that are associated with dowel failure, overlap. National codes of practice can be used as a guidance. For stud shear connectors a general requirement for minimum spacing [23] is that the connectors should be spaced at least four or five stud diameters apart; equivalent values can be used for other types of shear connectors.

When possible, the steel dowels should be placed in at least two rows [1] so that the connectors are able to redistribute their loads from one side of the push test to the other and hence fail as a single group of all the connectors within the push specimen. Otherwise, the failure load does not measure the mean strength of the shear connectors but measures the strength of the weakest side. Furthermore, as many connectors as possible should be tested in a single push specimen [1] as this reduces the scatter of results and hence fewer tests will be required to attain a specific degree of accuracy.

External restraint: The external restraints, as shown in Figs1-4&9, governs the axial force in the connectors.

Any system of restraints can be chosen for the fatigue tests. However it is worth bearing in mind that the systems in Figs.3&4 induce axial tensile forces which may cause embedment failure of the concrete slab and hence the restraints in Figs.1&2 may be considered better.

Testing Procedure

Two series of push tests will be required to derive the endurance of a new type of shear connector in a composite beam. One series of identically manufactured push specimens will be required to determine the static strength of the shear connection in a composite beam F_b from push tests. A further series of identically manufactured specimens will be required to determine the endurance N_e of shear connectors in the push tests and also to determine the static strength F_p of the shear connectors in the push tests.

Static strength in composite beam: One approach [1] is to vary the axial force in the shear connector as shown in Fig.11 and to assume that the static strength in a composite beam F_b is the same as that in the push test when the axial load in the connector is zero.

Endurance in push tests: Several push specimens, identical to the ones to be used in the fatigue tests, should be tested monotonically to failure to derive the static strength of the shear connection in the push specimen F_p . The endurance of the shear connectors N_e should then be determined experimentally by varying R/F_p .

Endurance in composite beams: The endurance of a shear connector in a composite beam is then given by substituting F_b for F_p in the prediction equation for N_e as derived in the previous section.

6. NOTATIONS

A	cross-sectional area of shank of stud
COV	SD as a proportion of the arithmetic mean of $\log_{10}N_e$ or $\log_{10}N_f$
E_c	Young's modulus concrete
E_s	Young's modulus stud material
F_b	static dowel strength in a composite beam
F_p	static dowel strength in a push specimen
f_c	cube strength of concrete
f_u	tensile strength of stud material
HS	highly significant
K	constant of fatigue prediction equation
k	proportion of applied load resisted by friction
m	exponent of fatigue prediction equation
N_d	characteristic endurance
N_e	endurance of uni-directionally loaded specimen
N_f	$N_e/(1-P/F_p)$
P	peak cyclic shear load; maximum shear load
R	range of cyclic load
S	significant
SD	standard deviation of $\log_{10}N_e$ or $\log_{10}N_f$
SD_e	standard deviation due to experimental error

7. REFERENCES

1. OEHLERS, D.J. and JOHNSON, R.P. The strength of stud shear connections in composite beams. *The Structural Engineer*, Vol, 65B, No. 2, June 1987, 44-48.
2. SLUTTER, R.G. and FISHER, J.W. Fatigue strength of shear connectors. *Highway Research Record No. 147*, 1966.
3. MAINSTONE, R.J. and MENZIES, J.B. Shear connectors in steel-concrete composite beams for bridges. 1: Static and fatigue tests on push out specimens. *Concrete*, 1967, 1, Sept., No. 9, 291-302.
4. TERASZKIEWICZ, J.S. Static and fatigue behaviour of simply supported and continuous composite beams of steel and concrete. Ph.D. thesis, University of London, 1967, Sept.
5. MENZIES, J.B. CP117 and shear connectors in steel-concrete composite beams made with normal-density or lightweight concrete. *Struct. Engr.*, 1971, 49, Mar., No. 3, 137-154.
6. GOSLING, P.A. Fatigue of shear connectors in composite beams. M.Sc. thesis, University of London, 1966, Sept.
7. FOLEY, L. The fatigue strength of stud shear connectors in push specimens. M.Eng.Sc. thesis, University College, Cork, 1983, August



8. HALLAM, M.W. The behaviour of stud shear connectors under repeating loading. University of Sydney, School of Civil Engineering, 1976, Aug., Research Report 281.
9. LO, K.K. Fatigue testing of stud shear connectors. M.Eng. thesis. University of Melbourne, 1978.
10. RODERICK, J.W. and ANSOURIAN, P. Repeated loading of composite beams. School of Civil Engineering, University of Sydney, 1976, Feb.. Research Report R280.
11. MAEDA, Y. and MATSUI, S. Effects of concrete placing direction on static and fatigue strengths of stud shear connectors. Technical reports of the Osaka University, Vol. 33, No. 1733, Oct., 1983, 397-406.
12. OEHLERS, D.J. The derivation of the fatigue endurance of stud shear connections in composite steel and concrete bridge beams. University of Adelaide, Department of Civil Engineering Report No. R81, November 1988.
13. EUROCODE NO. 4 Common unified rules for composite steel and concrete structures, (draft), Commission of the European Communities, Brussels, 1986.
14. ROIK, K. Composite road and railway bridges in Germany. Engineering Foundation Conference on Composite Construction. ASCE Conference Proceedings edited by Viest and Buckner, June 1987, 286-301.
15. BS5400, Steel, concrete and composite bridges: Part 10: Fatigue, 1980. British Standards Institution, London.
16. DAVIES, L.D. and GOLDSMITH, P.L. Statistical methods in research and production. Longman Group Limited. ISBN 0-582-03040-4, Fourth edition, 1980
17. OEHLERS, D.J. and FOLEY, L. The fatigue strength of stud shear connections in composite beams. Proc. Instn. Civ. Engrs., Part 2, 1985, 79, June, 349-364.
18. OEHLERS, D.J. and SINGLETON, W.M. The simulation of simply supported composite beams tested under fatigue loads. Proc. I.C.E. Part 2, 1986, 81, Dec. 647-657.
19. JOHNSON, R.P. Steel-Concrete Composite Structures - Stability and Strength - Composite Structures : A Preview. Edited by R. Narayanan, Elsevier Applied Science, London & New York, 1988.
20. OEHLERS, D.J. A new approach to the design of stud shear connectors in composite bridge beams: University of Adelaide, Department of Civil Engineering Report No. R81, November 1988.
21. OEHLERS, D.J. Splitting induced by shear connectors in composite beams: ASCE, Journal of Structural Engineering, Vol. 115, No. 2, Feb. 1989, 341-362.
22. JOHNSTON, R.P. and OEHLERS, D.J. Analysis and design for longitudinal shear in composite T-beams. Proc. Instn. Civ. Engrs., Part 2, 1981, 71, Dec., 989-1021.
23. JOHNSTON, R.P. and OEHLERS, D.J. Design for longitudinal shear in composite L-beams. Proc. Instn. Civ. Engrs., Part 2, 1982, 73, Mar., 147-170.