

# The Functura House - a factory fabricated one-family house of sheet steel construction

Autor(en): **Wallin, Lars**

Objektyp: **Article**

Zeitschrift: **IABSE reports of the working commissions = Rapports des commissions de travail AIPC = IVBH Berichte der Arbeitskommissionen**

Band (Jahr): **9 (1971)**

PDF erstellt am: **25.07.2024**

Persistenter Link: <https://doi.org/10.5169/seals-10367>

## **Nutzungsbedingungen**

Die ETH-Bibliothek ist Anbieterin der digitalisierten Zeitschriften. Sie besitzt keine Urheberrechte an den Inhalten der Zeitschriften. Die Rechte liegen in der Regel bei den Herausgebern.

Die auf der Plattform e-periodica veröffentlichten Dokumente stehen für nicht-kommerzielle Zwecke in Lehre und Forschung sowie für die private Nutzung frei zur Verfügung. Einzelne Dateien oder Ausdrucke aus diesem Angebot können zusammen mit diesen Nutzungsbedingungen und den korrekten Herkunftsbezeichnungen weitergegeben werden.

Das Veröffentlichen von Bildern in Print- und Online-Publikationen ist nur mit vorheriger Genehmigung der Rechteinhaber erlaubt. Die systematische Speicherung von Teilen des elektronischen Angebots auf anderen Servern bedarf ebenfalls des schriftlichen Einverständnisses der Rechteinhaber.

## **Haftungsausschluss**

Alle Angaben erfolgen ohne Gewähr für Vollständigkeit oder Richtigkeit. Es wird keine Haftung übernommen für Schäden durch die Verwendung von Informationen aus diesem Online-Angebot oder durch das Fehlen von Informationen. Dies gilt auch für Inhalte Dritter, die über dieses Angebot zugänglich sind.

**The Functura House – A Factory Fabricated One-Family House of Sheet Steel Construction**

La maison Functura – Villa en tôle d'acier produite en fabrique

Das Functura Haus – Ein in der Fabrik hergestelltes Einfamilienhaus aus Stahlblechkonstruktion

**LARS WALLIN**

Swedish Institute of Steel Construction  
Stockholm, Sweden

The Functura House is a factory fabricated one-family house of sheet steel construction developed and put into series fabrication of Junga Verkstäder in Sweden.

The Functura House is built entirely of cold-formed, trapezium-profiled galvanized sheet steel as a frameless building. The roof is free spanning over the width of the house to the load-bearing outer walls. The house is built of a number of similar sections with a floor area of 9 x 3 m or 27 m<sup>2</sup>. The sections are complete factory fabricated in series.

The roof structure consists of an outer A-shaped roof, a W-shaped reinforcing structure and a horizontal bottom plate, all made of trapezium-profiled sheet steel. The load-bearing outer walls, the floor and the outer roof consist of a sandwich-type structure of trapezium-profiled sheet steel with heat insulation in between.



All sheet steel is galvanized to 30  $\mu\text{m}$  zink thickness and all outer surfaces are plastic coated with 200  $\mu\text{m}$  Organosol. The plate thickness is 0,9 mm and the height of the trapezium-profile pattern is 45 mm.

The outer walls, the outer roof and the floor are built up in the same way consisting of from outside: plastic-coated trapezium-profiled sheet steel, insulating paper, heat insulation, and galvanized trapezium-profiled inner sheet steel. The heat insulation consists of mineral wool, 12 cm for walls and roof and 17 cm for the floor. The wall, roof and floor structure is kept together in the right position with wood spacers. The wall, roof, and floor design gives, besides a very good heat insulation, also a good acoustic insulation. Inner walls and ceilings are made of 13 mm plasterboard and the inner floor is made of 22 mm chipboard. Partitions are also made of plasterboard on a light steel frame, and partitions can be put into any position depending on the desired internal lay-out.

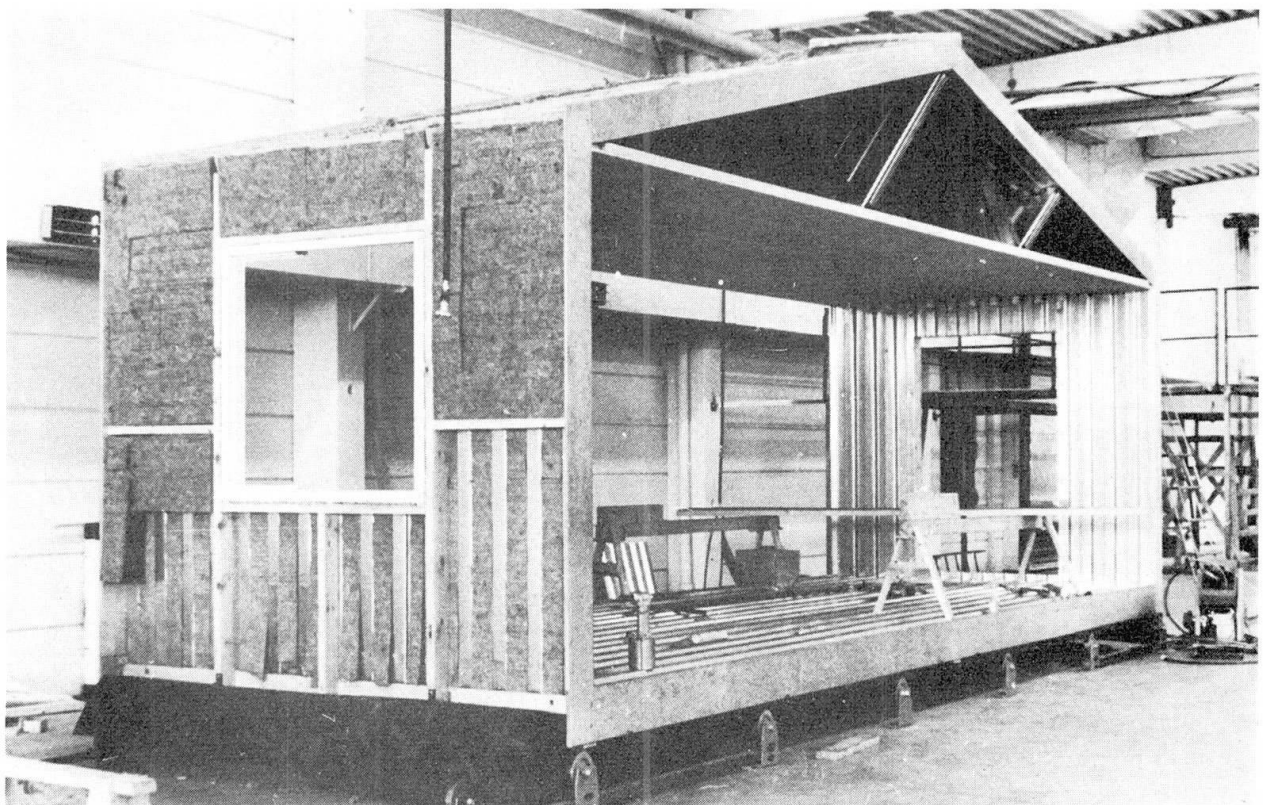
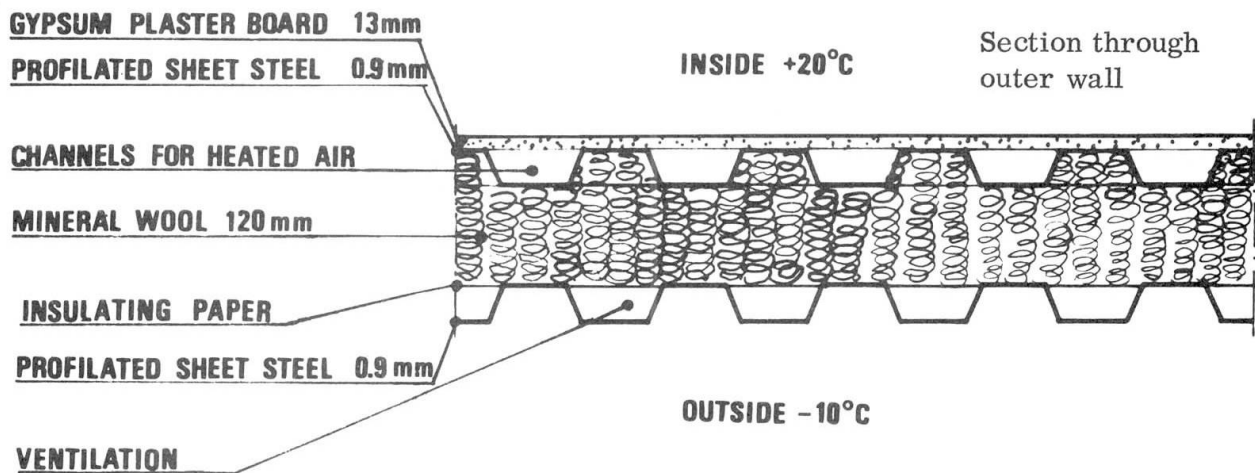

The house is built up of four, five, six or more similar sections, each of 27 m<sup>2</sup> floor area. Two of the sections are gable sections and one section is a wet section comprising kitchen, bathroom, toilette and heating unit. The different sections are all prized. An ordinary gable section costs appr. 17 500 Sw Cr (3 500 US \$) and an ordinary middle section costs appr. 13 500 Sw Cr (2 700 US \$). The wet section is the most expensive one with a price of appr. 42 000 Sw Cr (8 500 US \$). These prices include erection but of course not the lot, ground work and the freight. The price for an ordinary five section house of 135 m<sup>2</sup> floor area is thus appr. 104 000 Sw Cr (21 000 US \$). This price is much competitive in Sweden, especially as the house is made to a very high standard of equipment and installations.

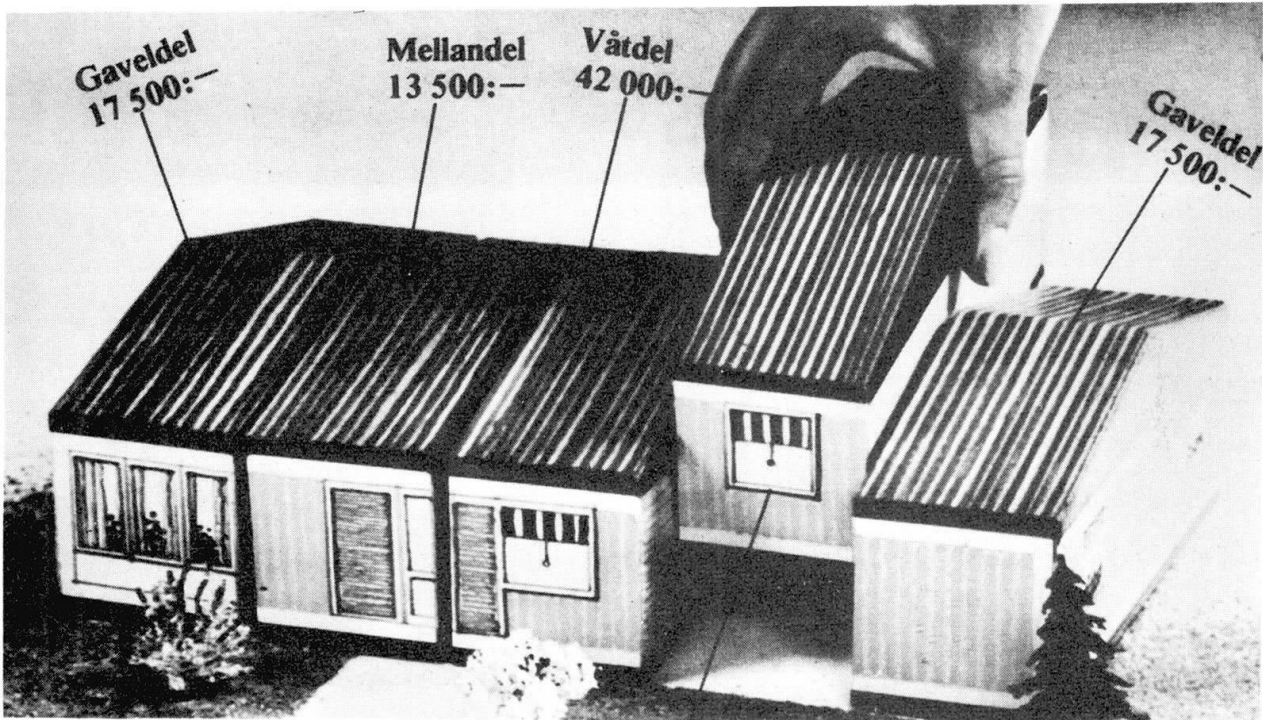



The house sections are delivered quite complete from the factory. Inner walls, partitions and wall papers, ceilings, inner floors and floor covers, cupboards and kitchen equipments, dishing and washing machines, heating, ventilation, sanitary and electrical equipment are all installed on the assembly line in the factory. All sections are structurally the same and made in the same way but furnished with different equipment.

The steel house is a light-weight structure. An ordinary middle section weights about 3 500 kg, a gable section 4 000 kg and the wet section with all its equipment 5 500 kg. The total weight of a five section house of 135 m<sup>2</sup> is thus about 20 500 kg. The steel weight is about half that total weight.

The house sections are delivered quite complete to the site and erected with a light mobile crane. Erection time is about two days. Erection is made with bolted joints.

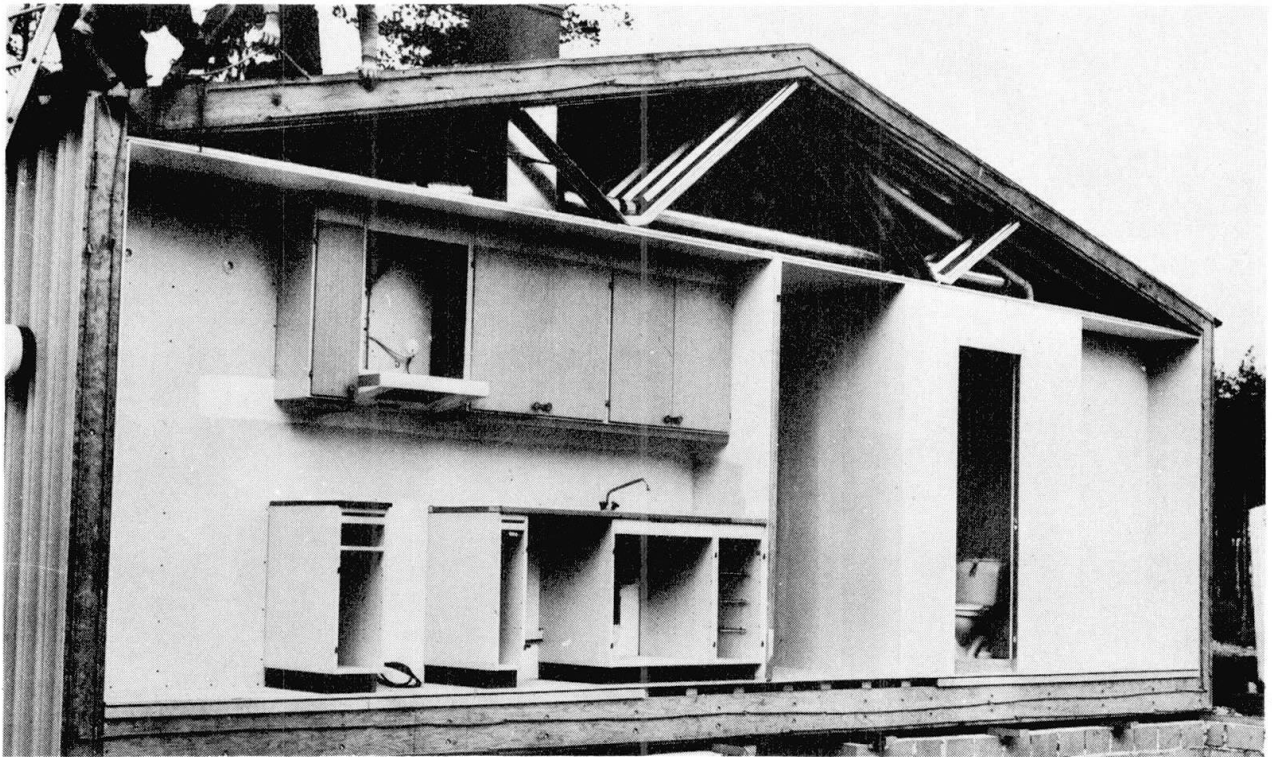

Wet section with kitchen, bathroom and WC

Heating of the Functura House is made in a quite unconventional way with heated air flowing in the channels between the trapezium-profiled sheet steel and the inner walls and floor. The air is heated in an electrical heating unit situated in the wet section. From there the heated air flows down into the floor, through the floor to the walls, up the walls to the roof, and back into the circulation. Some air can also enter the rooms beneath the windows. Some air is ventilated out and new fresh air is taken in and preheated by the circulating air in the roof. This heating system gives a very comfortable internal climate with even temperature, warm floors and walls, no draft, and clean air. The heating system is also very economical in operation. In a hot climate or during summer time the same system can also be used for circulating cooled air. Merely circulating air without cooling or heating gives actually a natural cooling effect.

## THE FUNCTURA STEEL HOUSE

Heating and ventilating system

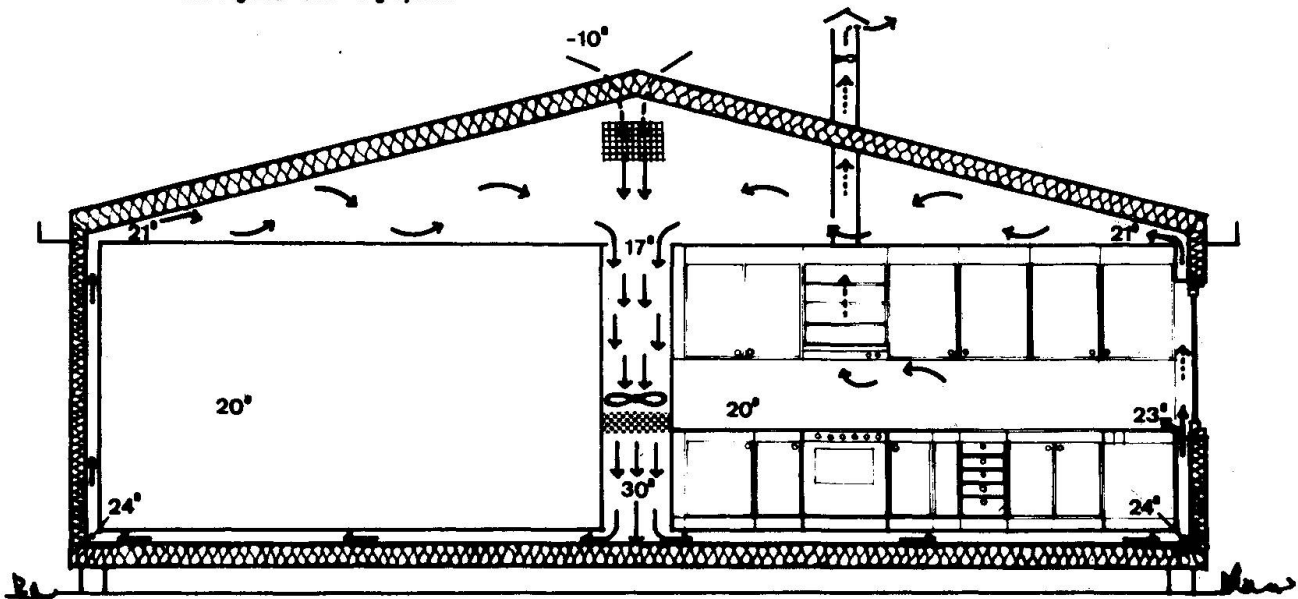

The Functura House can be delivered in different sizes, different colors, different shapes, and with different internal lay-out. A smaller house can later on very easily be enlarged by inserting another middle section. Garage and storage can be supplied with the house. Several Functura Houses can also be built together in a long row.

The Functura House can besides homes also be used as school buildings, smaller office buildings, and smaller commercial buildings.

The Functura House has proved quite competitive. The economy lies in the series fabrication with more than 85 % of the whole work being made on the assembly lines. The new heating system also contribute favourably to the over all economy.

## THE FUNCTURA STEEL HOUSE

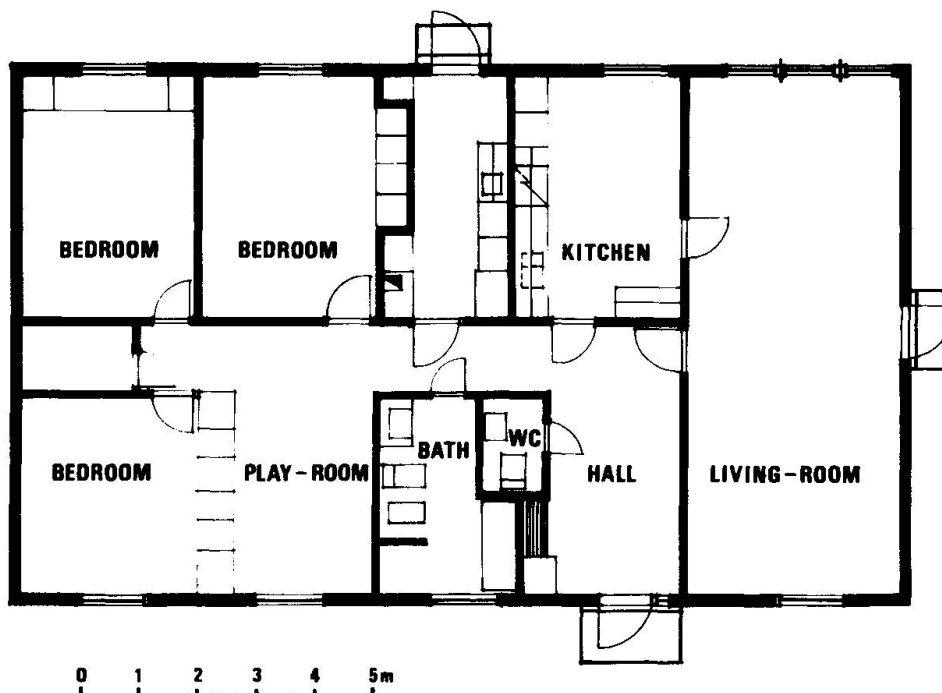

THE FUNCTURA STEEL HOUSE

Five section house

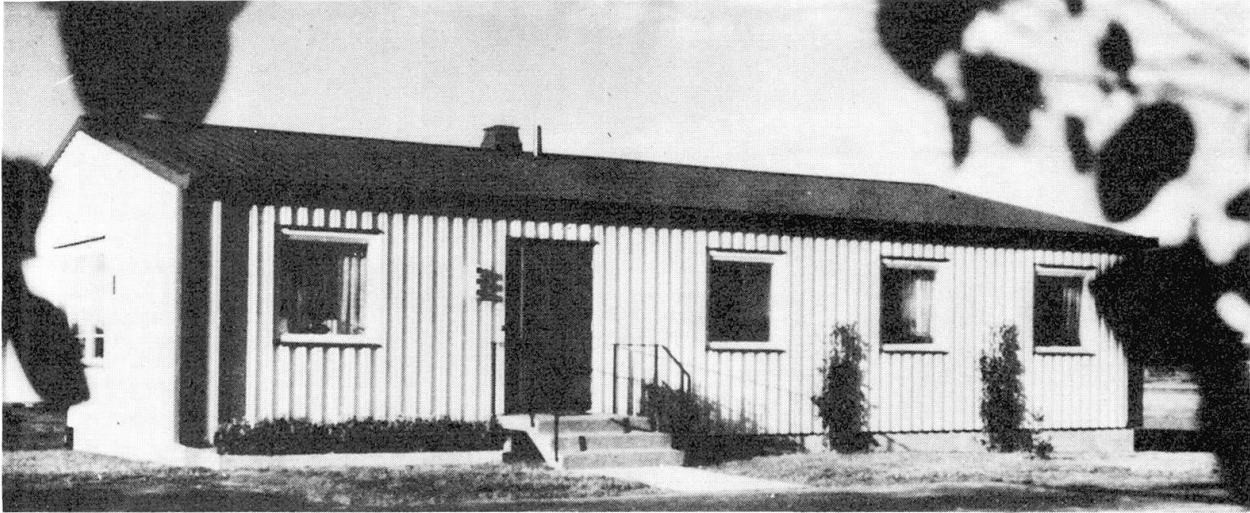

Six section house

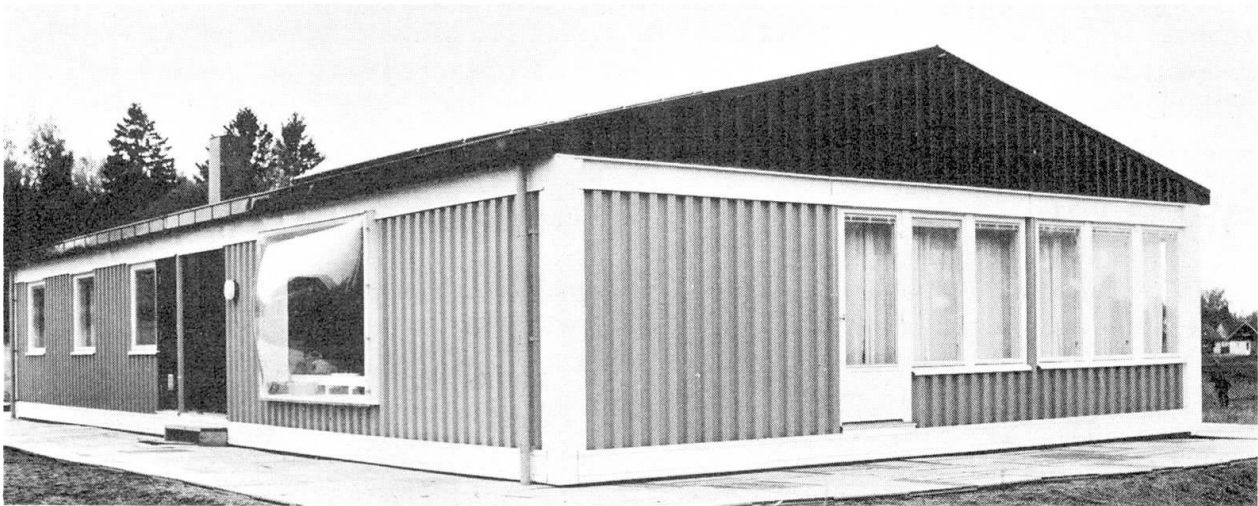

Six section house in angle



## SUMMARY

The Functura Steel House is a factory fabricated one-family house of sheet steel construction. The house is built entirely of cold-formed, trapezium-profiled sheet steel as a frameless building. The house consists of a number of structurally equal sections fabricated in series and delivered quite complete to the site.

## RESUME

La Maison Functura est une petite villa en tôle d'acier, produite en fabrique. La maison est composée uniquement de tôles pliées à froid en section trapézoïdale, sans squelette. Elle est divisée en un certain nombre d'éléments semblables, fabriqués en série et livrés sur place complets.

## ZUSAMMENFASSUNG

Das Functura-Haus ist ein in der Fabrik hergestelltes Einfamilienhaus aus Stahlblechkonstruktion. Das Haus ist durchwegs aus kaltgeformtem trapezprofilierem Stahlblech als gerippelose Einheit gebaut. Es besteht aus einer Anzahl strukturell gleicher Sektionen, die in Serien hergestellt und komplett auf den Platz geliefert werden.



Leere Seite  
Blank page  
Page vide