

Steel structures for composite bridge construction in the USSR

Autor(en): **Ghitman, E.M.**

Objektyp: **Article**

Zeitschrift: **IABSE reports of the working commissions = Rapports des commissions de travail AIPC = IVBH Berichte der Arbeitskommissionen**

Band (Jahr): **9 (1971)**

PDF erstellt am: **25.07.2024**

Persistenter Link: <https://doi.org/10.5169/seals-10376>

Nutzungsbedingungen

Die ETH-Bibliothek ist Anbieterin der digitalisierten Zeitschriften. Sie besitzt keine Urheberrechte an den Inhalten der Zeitschriften. Die Rechte liegen in der Regel bei den Herausgebern.

Die auf der Plattform e-periodica veröffentlichten Dokumente stehen für nicht-kommerzielle Zwecke in Lehre und Forschung sowie für die private Nutzung frei zur Verfügung. Einzelne Dateien oder Ausdrucke aus diesem Angebot können zusammen mit diesen Nutzungsbedingungen und den korrekten Herkunftsbezeichnungen weitergegeben werden.

Das Veröffentlichen von Bildern in Print- und Online-Publikationen ist nur mit vorheriger Genehmigung der Rechteinhaber erlaubt. Die systematische Speicherung von Teilen des elektronischen Angebots auf anderen Servern bedarf ebenfalls des schriftlichen Einverständnisses der Rechteinhaber.

Haftungsausschluss

Alle Angaben erfolgen ohne Gewähr für Vollständigkeit oder Richtigkeit. Es wird keine Haftung übernommen für Schäden durch die Verwendung von Informationen aus diesem Online-Angebot oder durch das Fehlen von Informationen. Dies gilt auch für Inhalte Dritter, die über dieses Angebot zugänglich sind.

IV

Steel Structures for Composite Bridge Construction in the USSR

Ponts à section mixte acier-béton en URSS

Stahlbauten für Verbundbrücken in der USSR

E.M. GHITMAN

Engineer

The All-Union Scientific
Research Institute of
Transport Construction
Moscow

There is a wide-spread application of composite superstructures in the USSR: these are simply supported in the railway bridges and both continuous and simply supported in the highway and urban bridges. This type of superstructure makes it possible to span 18 to 140-m gaps.

The application of the industrial techniques in bridge engineering practice necessitated the development of the composite spans that should be quite serviceable and simple in fabrication and erection. To satisfy these requirements, the typical highway and railway composite structures have been developed.

The typical highway composite spans are designed as a simply supported deck span type with span lengths of 42 m and 63m, and a continuous deck span type with span lengths of 3 x 42m; 42 + 63 + 42 m; 3 x 63 m; 63 + 84 + 63m; 63 + 2 x 84 + 63 m and 63 + 3 x 84 + 63 m. The typical cross-section of such a span is illustrated in fig.1.

The steel portion of the span consists of two main welded I-girders and an intermediate beam supported by the cross bracing. The main girders made of low-alloyed grade C-35 steel have the constant web depth (h_w) throughout the span lengths; the web depth for the span lengths of 42m; 42 + 63 + 42m and 3 x 42 m is equal to 2.48 m; for 63 m; 3 x 63 m and 63 + 84 + 63 m $h_w = 3.16$ m; for 63 + 2 x 84 + 63 m and 63 + 3 x 84 + 63 m $h_w = 3.60$.

The main steel girders are divided along the span into 21.0-m or 10.5 segments (for certain spans the length of the end segment is 16.05m). The web of each segment is reinforced against buckling with vertical and horizontal stiffening ribs.

The intermediate beam is also divided into 10.49 m long segments (the web depth of this is 0.40 m for all spans).

Field connections between the segments are carried out using high-strength bolts.

The steel portion of a superstructure is placed in position

FIG 2

Typical cross-sections

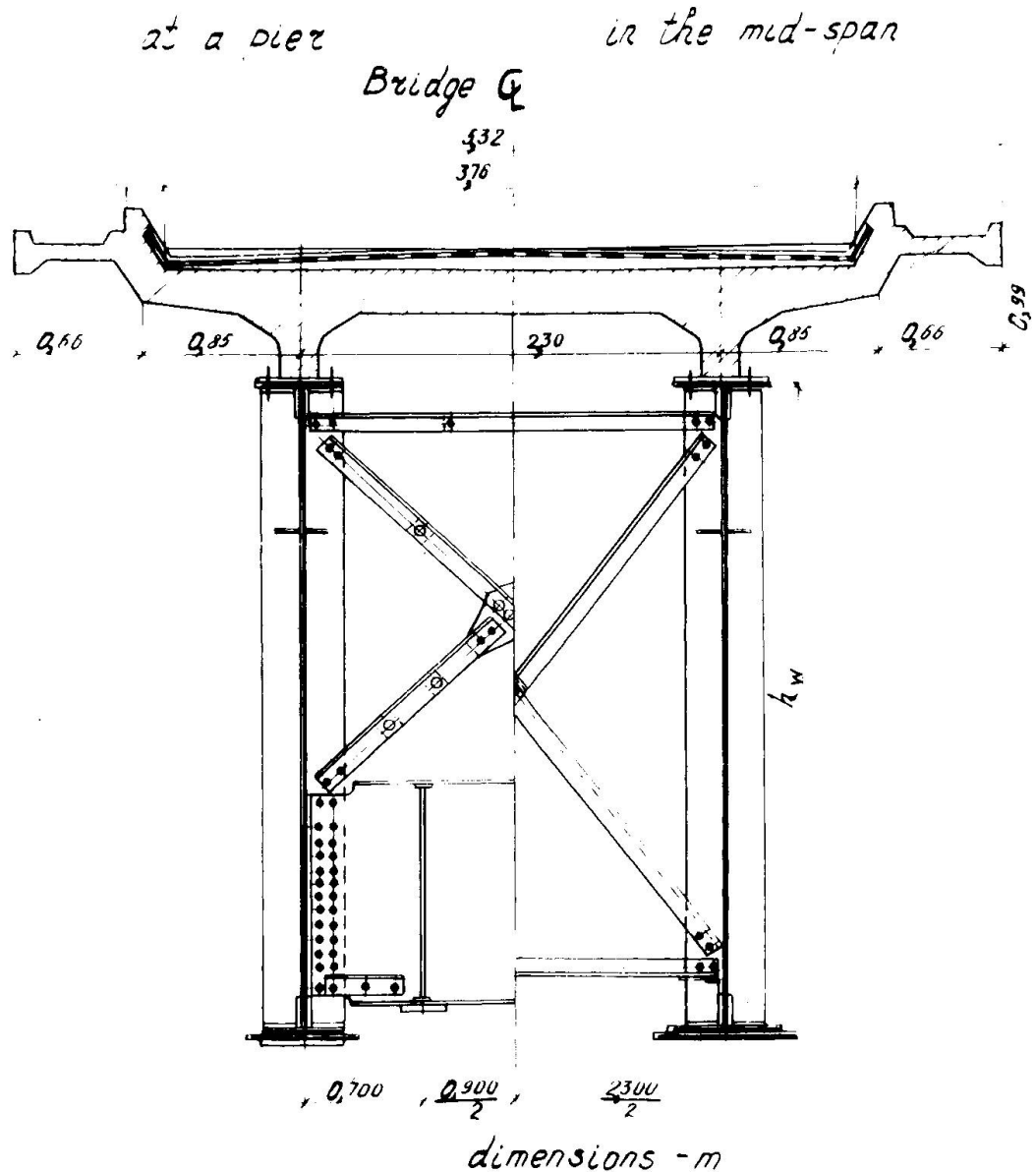

deck slabs. These are connected to the steel girders either using rigid studs, or high-strength bolts and epoxy-resin based glue; the latter being recognised in the USSR as the most efficient technique as much in terms of providing the connection reliability of the structure in service conditions as in terms of the convenience of including the precast deck slab into composite action with the steel girders during the cold seasons.

Along with the typical composite steel structures there are individual structures used in the USSR for the urban bridges (usually continuous).

The steel portion of these structures is formed either by plate girder of the constant or variable depth, or by single or multiple steel box girders.

An example of application of the individually designed, continuous, composite structure is the bridge recently built in Moscow with the spans of 81 + 135 + 81 m. A cross-section within the region of action of the negative bending moments is shown in fig.3.

*Typical cross-section
at a pier.*

Bridge G

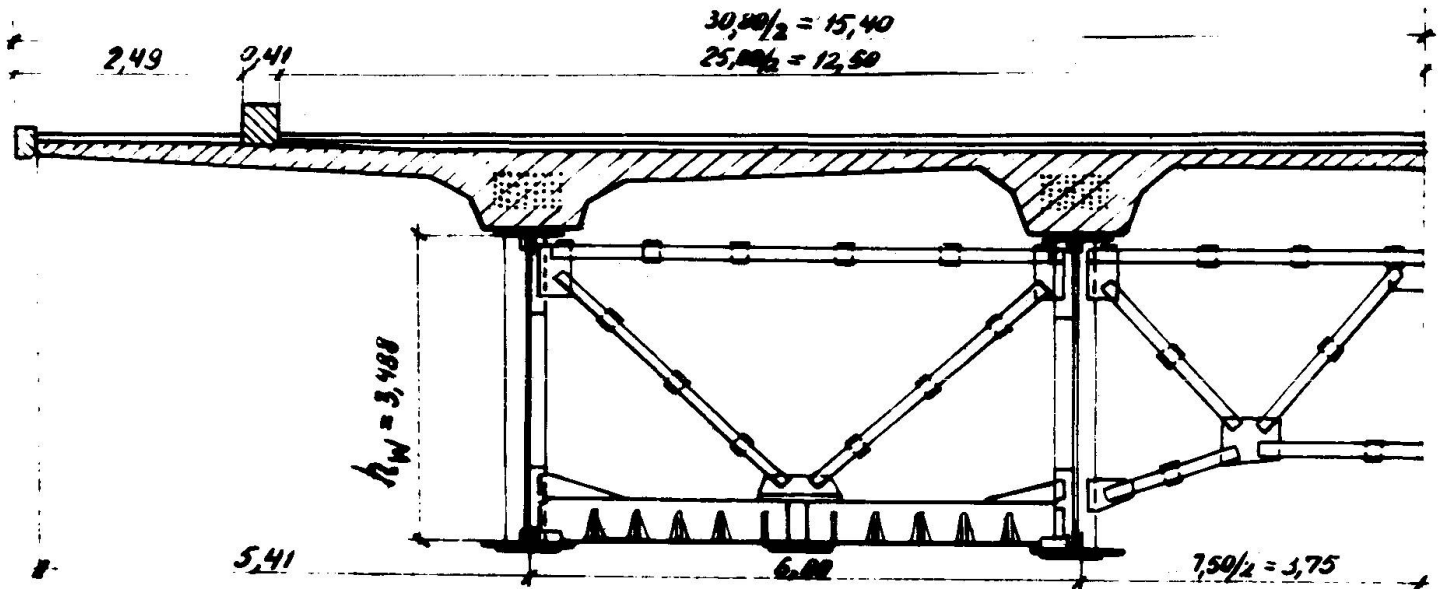

dimensions - m

FIG. 3

The steel portion of the bridge structure consists of four welded I-beams with the constant web depth ($h_w = 3.488\text{m}$). The beams are coupled at the bottom along the most part of their length by a ribbed metal plate with the thickness varying along the span from 0.040 to 0.010m. The combining is carried out in such a manner that there are two 6.0 m - wide boxes with 13.5 m between centers appearing in the cross-section. The girders and the bottom ribbed plate are made of low-alloyed high-strength C-40 grade steel.

The erection started with installing the pier diaphragms, followed by the installation of the steel girders fabricated in 13.1 to 15.5 m - long segments and connected to each other by the automatic welding process. Simultaneously, the bottom ribbed metal plates, also divided into segments, were placed and butt-welded to each other and, in a lapped manner, to the bottom flanges. And after all, the transverse ribs of the bottom plate and the cross-bracing inside the boxes were installed and welded.

The precast/cast-in-place reinforced concrete deck slab of the above superstructure was prestressed by tendons in the regions of the negative bending moments.

At the present time, the development of typical composite superstructures with steel boxes is under way in the USSR. For example, for the railway simply-supported composite structures with the 45.0 and 55.0 m - long spans the steel portion is formed by two vertical webs with a constant depth throughout the span and placed 1.8 m apart from each other, the bottom ribbed 2.4 m - wide plate and the top horizontal 0.48 m - wide plates.

The turn over to the production of the steel boxes for, say, the simply-supported span structures of 45.0 m, will permit to deliver these in a ready-to-erection state and avoid the intermediate operations in placing them in position.

The elimination of the cross-bracing results in simplifying the prefabrication procedure and the saving of metal amounting to 10 percents.

SUMMARY

Typical highway and railway composite bridges as well as an urban highway bridge with the superstructure having an individually fabricated steel portion, are described in this paper. For typical composite spans in the USSR welded I-girders are used with the unified web depth and lengths of the segments, which permits their serial production; for urban bridges steel girders of both open and box section are used without unification of the general dimensions and produced individually for every site.

RESUME

On décrit dans cet article des ponts-routes et des ponts-raills typiques ainsi qu'un pont d'une autoroute urbaine, où la superstructure est composée d'éléments en acier fabriqués individuellement.

On dispose, pour plusieurs portées différentes de ponts mixtes en URSS de profils soudés en I avec une hauteur d'âme et des longueurs de segments unifiés, ce qui permet une exécution en série. Pour les ponts urbains, on utilise des sections ouvertes aussi bien que des sections en caisson, sans aucune standardisation des dimensions principales, avec une exécution individuelle.

ZUSAMMENFASSUNG

Im vorliegenden Beitrag werden typische Strassen- und Eisenbahnbrücken sowie eine Stadtstrassenbrücke mit einem aus einzelnen Stahlteilen fabrizierten Oberbau beschrieben. Für typische Verbundöffnungen werden in der USSR geschweisste I-Träger mit vereinheitlichter Steghöhe und Länge der Segmente verwendet, was Serienanfertigung erlaubt; für Brücken im Stadtbereich werden Stahlträger sowohl mit offenem wie mit Kastenquerschnitt ohne Vereinheitlichung der Hauptabmessungen benutzt und für jede Baustelle individuell angefertigt.

Leere Seite
Blank page
Page vide