

# An experimental study on the hysteretic behaviour of steel braces under repeated loading

Autor(en): **Morino, Shosuke**

Objektyp: **Article**

Zeitschrift: **IABSE reports of the working commissions = Rapports des commissions de travail AIPC = IVBH Berichte der Arbeitskommissionen**

Band (Jahr): **14 (1973)**

PDF erstellt am: **21.07.2024**

Persistenter Link: <https://doi.org/10.5169/seals-14472>

## **Nutzungsbedingungen**

Die ETH-Bibliothek ist Anbieterin der digitalisierten Zeitschriften. Sie besitzt keine Urheberrechte an den Inhalten der Zeitschriften. Die Rechte liegen in der Regel bei den Herausgebern.

Die auf der Plattform e-periodica veröffentlichten Dokumente stehen für nicht-kommerzielle Zwecke in Lehre und Forschung sowie für die private Nutzung frei zur Verfügung. Einzelne Dateien oder Ausdrucke aus diesem Angebot können zusammen mit diesen Nutzungsbedingungen und den korrekten Herkunftsbezeichnungen weitergegeben werden.

Das Veröffentlichen von Bildern in Print- und Online-Publikationen ist nur mit vorheriger Genehmigung der Rechteinhaber erlaubt. Die systematische Speicherung von Teilen des elektronischen Angebots auf anderen Servern bedarf ebenfalls des schriftlichen Einverständnisses der Rechteinhaber.

## **Haftungsausschluss**

Alle Angaben erfolgen ohne Gewähr für Vollständigkeit oder Richtigkeit. Es wird keine Haftung übernommen für Schäden durch die Verwendung von Informationen aus diesem Online-Angebot oder durch das Fehlen von Informationen. Dies gilt auch für Inhalte Dritter, die über dieses Angebot zugänglich sind.

## DISCUSSION LIBRE • FREIE DISKUSSION • FREE DISCUSSION

**An Experimental Study on the Hysteretic Behaviour of Steel Braces under Repeated Loading**

Etude expérimentale sur le comportement hystérique de parois en acier sous charge répétée

Eine experimentelle Studie über das Hysterese-Verhalten von Stahlblech-wänden unter wiederholter Belastung

Shosuke MORINO

Ph. D.

Disaster Prevention Research Institute  
Kyoto University, Japan

**INTRODUCTION** It is well known that braces provide the sufficient strength and rigidity to the structure under the horizontal loading. In Fig. 1, hysteretic load-deflection curves of unbraced and braced frames are shown. In spite of the obvious difference in the shapes of hysteretic loops observed from Fig. 1, the dynamic analysis carried in the present design practice often assumes the multi-linear type of hysteretic load-deflection model for both unbraced and braced frames. This difference is mainly caused by the unique feature of the hysteretic load-deflection characteristics of the brace itself, and it is thus essential to know the real behavior of a bar under repeated axial tension and compression, which should simulate the behavior of the brace involved in a real braced frame.

Investigations on the post-buckling behavior of a bar was initiated in order to obtain the ultimate strength of the truss. Masur<sup>(1)</sup> carried out a theoretical study on the ultimate strength of a simple indeterminate truss. Murray<sup>(2, 3)</sup> described the behavior of a bar with residual deflection under eccentric loading by the elastic action and a plastic mechanism curve, and compared his results with test results of triangular and Warren type trusses. Tests of triangular and Warren type trusses were conducted by Nutt<sup>(4)</sup>, and Neal and Griffiths<sup>(5)</sup> reported an approach to obtain the ultimate strength of a truss. Analysis and test of a simply supported column under pure compression were reported by Paris<sup>(6)</sup>.

Experimental investigations on the behavior of braced frames were done by Wakabayashi, et al<sup>(7)</sup>. Fujimoto, et al.<sup>(8)</sup> showed the results of finite element type numerical analysis of behaviors of braces and braced frames. Igarashi, et al.<sup>(9)</sup> derived the relation between the increments of applied force and deformation of a brace based on a yield condition for a rectangular cross section and flow rule, and analysed the behavior of a brace and braced frame. Nonaka<sup>(10)</sup> obtained an analytical solution for the hysteretic behavior of a centrally loaded steel bar, introducing a plastic hinge at the center which was defined by a linear yield condition of the cross section. Shibata, et al.<sup>(11)</sup> took an approach to the problem in which the deformation distributed along the longitudinal axis of a bar is assumed to be concentrated within a flexural

portion located at the center with a certain length, so that the effect of the partial yield of the cross section could be taken into account. Higginbotham and Hanson<sup>(12)</sup> conducted the analysis including the nonlinear term of the curvature. Yamada and Tsuji<sup>(13)</sup> analysed a bar under repeated axial loading, assuming bi-linear type stress-strain curve and simplifying the section into 3-point model. Very similar experimental study to the one presented in this paper was already conducted by Wakabayashi, et al<sup>(14)</sup>.

**TESTS** Shape and size of a specimen manufactured by shapering SS41 mild steel sheet are shown in Fig. 2. All specimens have square cross section with nominal size 15mm x 15mm, and the value of the length  $\ell$  (Fig. 2) divided by the radius of gyration varies from about 40 to 160. When a specimen is fixed in the loading apparatus described later, rotation axes of the apparatus are to lie at both ends of the length  $\ell$ . Measured dimensions and slenderness ratio are shown in Table 1.  $N_{cr}$  in Table 1 is observed buckling load. Each specimen name listed in Table 1 is composed of two alphabets and numerals. First letter denotes the loading condition; repeated (R) or monotonic (M). Second denotes the position of the load; centric (C) or eccentric (E). Numerals indicate an approximate value of the slenderness ratio. The specimens with the letter R at the end of their names are tested under the different loading program from others, as described later. The eccentricity is given by the formula,  $i/20 + \ell/500$ , where  $i$  is the radius of gyration. Mean values of mechanical properties of the steel material used are shown in Table 2, and a typical stress-strain curve in Fig. 3.

Figure 4 shows the loading apparatus with a deflected specimen. The apparatus is mainly composed of two frames; inner and outer frames. The outer frame is fixed to the cross head or the bed of Autograph universal testing machine, and the inner frame supporting the specimen can freely rotate about the rotation axis at which two frames are connected with no rotational friction by means of thrust and radial bearings.

Starting from the virgin compression, all specimens except RC40R and RC100R are first subjected to a few cycles of alternately repeated axial loading, with relative axial displacement amplitude being controlled at a prescribed value ( $\Delta/\ell = 0.005$ ). After hysteresis loops stabilize, the controlling displacement amplitude is increased by the amount of 0.5% of the specimen length  $\ell$ , and another few cycles of loading are applied. RC40R is first subjected to the virgin tensile loading, and subsequent repeated loading is so applied that only tensile axial displacement occurs. The loading program for RC100R shown in Fig. 23, is determined to investigate the stabilization of the hysteresis loops under the repeated loading with small displacement amplitude, after the specimen experiences the large displacement.

**TEST RESULTS** In Figs. 5-22, test results of the load (N) - relative axial displacement ( $\Delta$ ) and the load (N) - midpoint lateral deflection (V) relationships are shown, referring to Fig. 24. Buckling behaviors of specimens tested under the monotonic loading are shown in Figs. 5-11. Euler loads computed for the specimens which buckled elastically show a good agreement with the experimental buckling loads, and this is believed to guarantee the supporting pin in Fig. 4 worked ideally.

Test results under repeated loading are shown in Figs. 12-22. General behavior of a steel bar under repeated centric axial loading observed from the test can be explained referring to the schematically drawn hysteresis loops in Fig. 25. Under the virgin compression, the bar is shortened keeping its straightness from point O. When it buckles at point A, the sustained load decreases to point B with a very rapid increase of both the axial displacement

and the lateral deflection (point B'). After the loading direction is reversed at prescribed turning point B, the slope of the hysteresis curve at point B is much smaller than the initial elastic slope due to the existence of the lateral deflection. The curve, then, once shows still smaller slope, and proceeds to point D, the slope being steeper. The plastic elongation occurs at point D and the plateau between points D and E corresponds to the plateau of the stress-strain curve of the material. A point which should be noted is that the lateral deflection does not decrease much (points D' to E') even when the load-axial displacement curve shows the plateau, and thus the small lateral deflection remains at the turning point E. Because of this residual lateral deflection, the maximum compressive strength of the bar in the second cycle attained at point G is much smaller than the first one at point A, and sudden buckling action does not appear. After the loading direction is again reversed at point H, the curve goes to point I following nearly the same path with B-C-D. But, the plateau does not appear this time and the maximum tensile strength attained at point I is much smaller than that at point E. The loop in the third cycle is similar to that in the second cycle, and the loop stabilizes after a few cycles of loading.

Regardless the number of the loading cycle, the end of specimen under central loading rotates about the pin axis always in the same direction which is determined at the time of the buckling under the virgin compression. However, in case of eccentrically loaded specimens, the direction of the rotation at the end is reversed when the first tension load is applied right after the buckling occurs under the virgin compression. This phenomenon is exaggerated when the slenderness ratio becomes large.

A test result for RC100R in Fig. 22 under the loading program in Fig. 23 demonstrates the rapid stabilization of the hysteresis loops within the small displacement amplitude ( $\Delta/l = \pm 0.5\%$ ), after the specimen experiences the repeated loading within the large amplitude ( $\Delta/l = \pm 1.0\%$ ).

EXPERIMENTAL OBSERVATIONS The following observations are made.

1. Regardless the axial displacement amplitude, the hysteresis loop stabilizes after 5 to 10 cycles of loading. It seems that the loop of a specimen with larger slenderness ratio stabilizes faster. The loop stabilization of an eccentrically loaded specimen is slightly delayed in comparison with centrally loaded one.

2. When the repeated loading with the small displacement amplitude is applied on a specimen which has already experienced the larger displacement, the hysteresis loop promptly stabilizes (Fig. 22).

3. Once the plastic deformation occurs in a specimen due to the buckling, the lateral deflection does not disappear even when the specimen is subjected to considerable amount of the elongation. The residual lateral deflection measured at zero load tends to gradually increase as the number of loading cycle becomes larger, and thus both maximum tensile and compressive strengths obtained in each cycle of loading under the prescribed displacement amplitude become smaller.

4. The centrally loaded specimen keeps the single-curvature deflected shape resulted from the buckling, during the whole history of loading. On the other hand, two inflection points of the curvature appears near ends of the eccentrically loaded specimen, when the first tensile load is applied after the buckling occurs. This deflected shape is exaggerated in the long specimens.

5. The slope of N- $\Delta$  hysteresis loop at the point at which the load is changed from compression to tension (for example, point C in Fig. 25) becomes smaller, as the number of loading cycle, slenderness ratio and controlling displacement amplitude become larger. The slope of the loop when the load changes from tension to compression is nearly equal to the initial elastic slope, since the effect of the lateral deflection is small.

6. The phenomenon described in the above items 1, 3, 4 and 5 are also observed in the test of RC40R, subjected to the cyclic loading causing only tensile axial displacement (Fig. 21).

7. General observation of the stabilized hysteresis loops of each specimen may derive the conclusion that the compressive load carrying capacity and the hysteretic energy absorbing capacity are not much expected in the case of the long specimen. The most critical point may be that the maximum tensile strength appearing in the stabilized hysteresis loop obtained under a prescribed displacement amplitude is much less than the yield load obtained from the usual tension test.

ACKNOWLEDGEMENT The study presented in this paper was done as a part of the project entitled "Studies on the Elastic-Plastic Behavior of the Steel Braces under Repeated Axial Loading" sponsored by the Ministry of Education, Japan. The head of the project is Prof. Minoru Wakabayashi, Kyoto University. Principal investigators involved in the experimental study are Prof. Chiaki Matsui, Kyusyu University, Messrs. Takeshi Nakamura and Nozomu Yoshida, Kyoto University, including the author. Theoretical investigations are taken part in mainly by Prof. Taijiro Nonaka, Kyoto University, and Prof. Michio Shibata, Osaka Institute of Technology. The author wishes to express his sincere appreciation for the advice, comments and criticisms received from them.

References 10 and 11 have been published in relation to this project, and preliminary investigations prior to this project was reported in Ref. 13.

Acknowledgements are also due Prof. Tsuneyoshi Nakamura, Kyoto University, and Prof. Ryoichi Sasaki, Osaka Technical High School, who kindly offered testing facilities.

#### REFERENCES

1. Masur, E. F.: POST BUCKLING STRENGTH OF REDUNDANT TRUSSES, Proc. ASCE, Vol. 79, No. 332, Oct. 1953, pp. 332-1-14.
2. Murray, N. W.: THE DETERMINATION OF THE COLLAPSE LOADS OF RIGIDLY JOINTED FRAMEWORKS WITH MEMBERS IN WHICH THE AXIAL FORCES ARE LARGE, Proc. ICE, Vol. 5, April 1956, pp. 213-232.
3. Murray, N. W.: FURTHER TESTS ON BRACED FRAMEWORKS, Proc. ICE, Vol. 10, Aug. 1958, pp. 503-516.
4. Nutt, J. G.: THE COLLAPSE OF TRIANGULATED TRUSSES BY BUCKLING WITHIN THE PLANE OF TRUSSES, The Structural Engineer, Vol. 37, May 1959, pp. 141-149.
5. Neal, B. G. and Griffiths, D. M.: THE COLLAPSE OF RIGIDLY JOINTED SINGLY REDUNDANT LIGHT ALLOY TRUSSES, The Structural Engineer, Vol. 41, Dec. 1963, pp. 399-406.
6. Paris, P. C.: LIMIT DESIGN OF COLUMNS, J. Aeronautical Sciences, Vol. 21, No. 1, 1954, pp. 43-49.
7. Wakabayashi, M. and Tsuji, B.: EXPERIMENTAL INVESTIGATION ON THE BEHAVIOR OF FRAMES WITH AND WITHOUT BRACING UNDER HORIZONTAL LOADING, Bulletin, Disaster Prevention Research Institute, Kyoto University, Vol. 16, Part 2, Jan. 1967, pp. 81-96.
8. Fujimoto, M. et al.: NONLINEAR ANALYSIS FOR K-TYPE BRACED STEEL FRAMES,

- Transaction, Architectural Institute of Japan, No. 209, July 1973, pp. 41-51(in Japanese).
9. Igarashi, S., et al.:HYSTERETIC CHARACTERISTICS OF STEEL BRACED FRAMES, Transaction, Architectural Institute of Japan, No. 196, June 1972, pp. 47-54(In Japanese).
  10. Nonaka, T.:AN ELASTIC-PLASTIC ANALYSIS OF A BAR UNDER REPEATED AXIAL LOADING, Int. Jour. Solids and Structures, Vol. 9, No. 5, May 1973, pp. 569-580.
  11. Shibata, M., et al.:ELASTIC-PLASTIC BEHAVIOR OF STEEL BRACES UNDER REPEATED AXIAL LOADING, Preprint, 5th WCEE, Rome, 1973, No. 100.
  12. Higginbotham, A. B. and Hanson, R. D.:INELASTIC CYCLIC BEHAVIOR OF AXIALLY-LOADED MEMBERS, Presented at Annual Meeting of CRC in Chicago, Mar. 1972.
  13. Yamada, M. and Tsuji, B.:ELASTO-PLASTIC BEHAVIOR OF BRACINGS UNDER THE CYCLIC AXIAL FORCES (PART I), Transaction, Architectural Institute of Japan, No.205, March 1973, pp. 31-35 (in Japanese).
  14. Wakabayashi, M., et al.:AN EXPERIMENT ON THE BEHAVIOR OF A STEEL BAR UNDER REPEATED AXIAL LOADING, Annuals, Disaster Prevention Research Institute, Kyoto University, No. 14A, April 1971, pp. 371-381 (in Japanese).

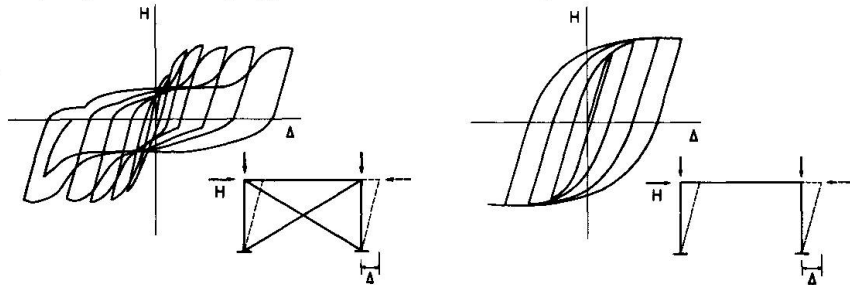
**FIGURES AND TABLES**

**Table 1 Size of Specimens**

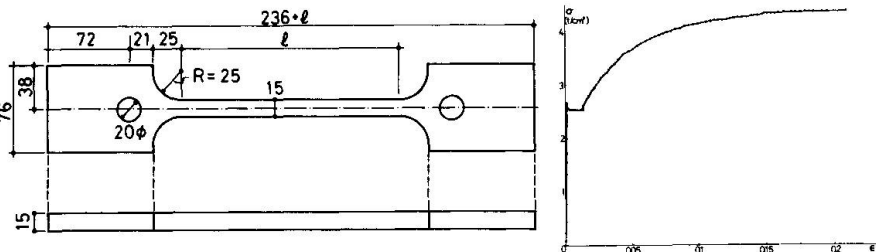
| SPECIMEN NAME | LENGTH (cm) | WIDTH (mm) | DEPTH (mm) | SLENDERNESS RATIO | $N_{cr}$ (t) |
|---------------|-------------|------------|------------|-------------------|--------------|
| MC 40         | 19.37       | 14.97      | 15.01      | 44.70             | 5.82         |
| MC 80         | 36.78       | 15.01      | 15.05      | 84.67             | 5.22         |
| MC 120        | 54.01       | 14.97      | 15.03      | 124.48            | 3.17         |
| MC 160        | 71.39       | 14.95      | 15.02      | 164.64            | 1.93         |
| ME 40         | 19.39       | 14.97      | 15.04      | 44.65             | 5.10         |
| ME 80         | 36.70       | 15.00      | 15.03      | 84.47             | 3.67         |
| ME 120        | 54.01       | 15.00      | 15.03      | 124.48            | 2.29         |
| RC 40         | 19.50       | 15.06      | 15.08      | 44.80             | 6.23         |
| RC 40R        | 19.33       | 14.96      | 15.09      | 44.43             | 5.25         |
| RC 60         | 27.99       | 14.99      | 15.03      | 64.51             | 5.94         |
| RC 80         | 35.65       | 15.05      | 14.95      | 85.43             | 5.49         |
| RC 100        | 45.32       | 15.01      | 15.06      | 104.26            | 3.60         |
| RC 100R       | 45.29       | 15.01      | 15.04      | 104.31            | 2.60         |
| RC 120        | 54.05       | 14.99      | 15.02      | 124.65            | 3.72         |
| RC 160        | 71.33       | 15.01      | 15.03      | 164.39            | 2.32         |
| RE 40         | 19.29       | 14.98      | 15.06      | 44.38             | 5.29         |
| RE 80         | 36.67       | 15.01      | 15.03      | 84.51             | 3.81         |
| RE 120        | 54.01       | 14.99      | 15.03      | 124.48            | 2.58         |

**Table 2 Mechanical Properties**

|                         |                                   |
|-------------------------|-----------------------------------|
| YOUNG'S MODULUS         | $2.18 \times 10^3 \text{ t/cm}^2$ |
| YIELD STRESS            | $2.55 \text{ t/cm}^2$             |
| ULTIMATE STRENGTH       | $4.37 \text{ t/cm}^2$             |
| STRAIN-HARDENING STRAIN | 1.3 %                             |
| EXTENSIBILITY           | 31.8 %                            |
| STRENGTH OF RUPTURE     | $3.15 \text{ t/cm}^2$             |

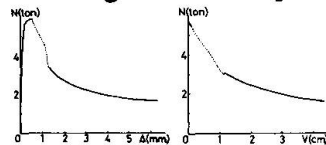


**Fig. 1 Hysteresis Loops of Braced and Unbraced Frames**



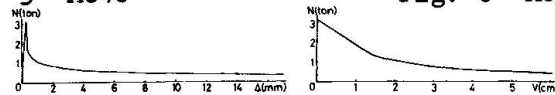
**Fig. 2 Test Specimen**

**Fig. 3 Stress-Strain Curve**

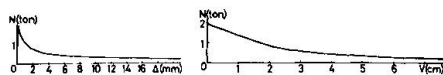


**Fig. 5 MC40**

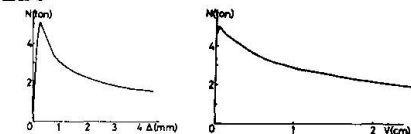
**Fig. 6 MC80**



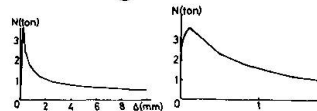
**Fig. 7 MC120**



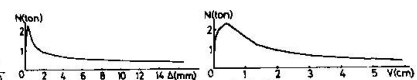
**Fig. 8 MC160**



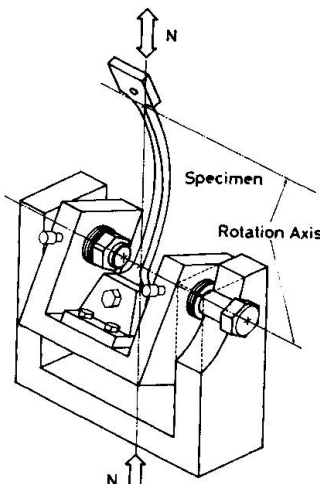
**Fig. 9 ME40**



**Fig. 10 ME80**



**Fig. 11 ME120**



**Fig. 4 End Support**

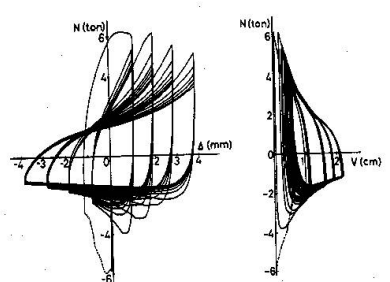


Fig. 12 RC40

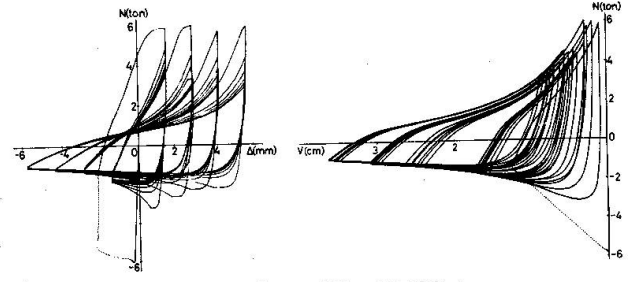


Fig. 13 RC60

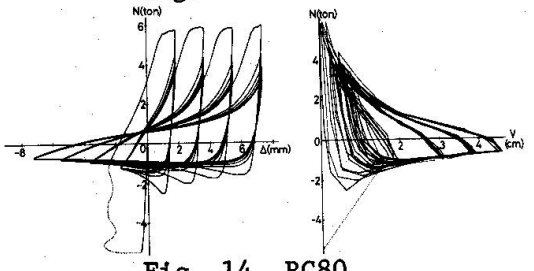


Fig. 14 RC80

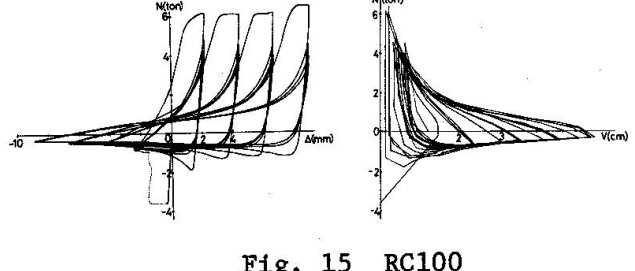


Fig. 15 RC100

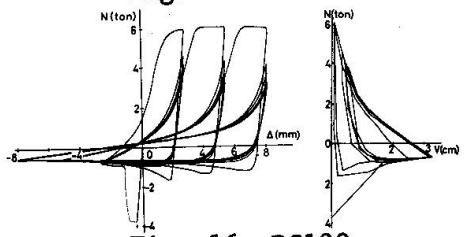


Fig. 16 RC120

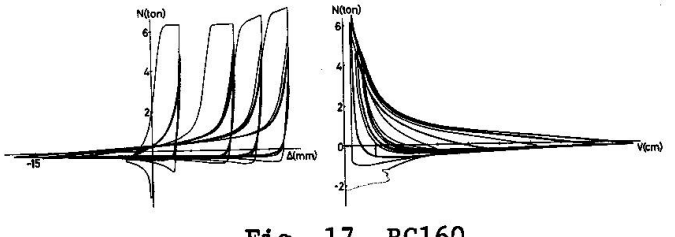


Fig. 17 RC160

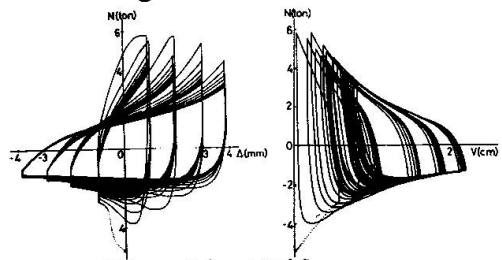


Fig. 18 RE40

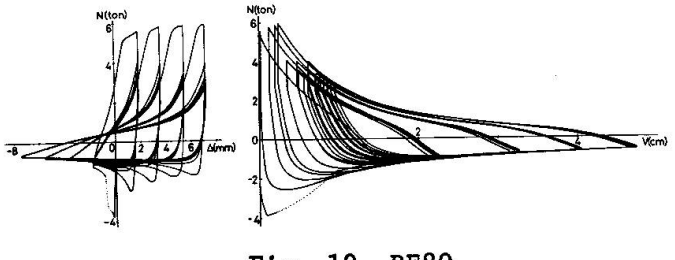


Fig. 19 RE80

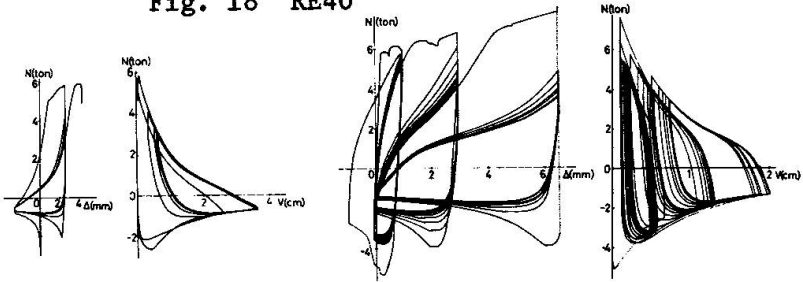


Fig. 20 RE120

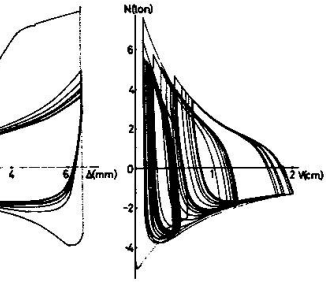


Fig. 21 RC40R

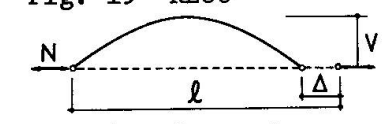


Fig. 24 Deformations

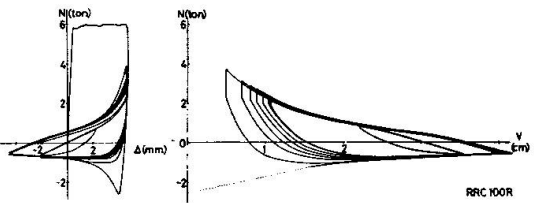


Fig. 22 RC100R

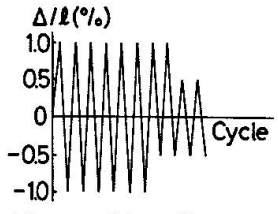


Fig. 23 Loading Program for RC100R

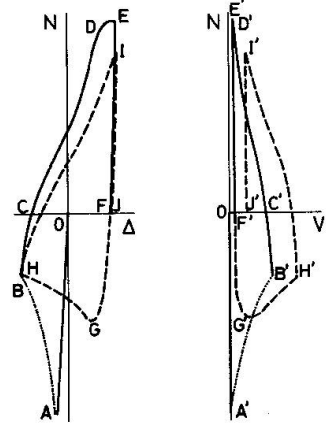


Fig. 25 Schematic Hysteresis Loops

## SUMMARY

An experimental study is carried out in order to investigate the hysteretic behavior of steel braces subjected to repeated axial tension and compression. In the test program, all specimens of SS41 mild steel bar simply supported at both ends have an identical cross section with a nominal dimension 15 mm x 15 mm, and slenderness ratio varies from about 40 to 160. The repeated axial load is applied centrally or eccentrically on the specimen through the loading apparatus which assures free rotation at both ends of the specimen, under the loading program that controls the relative axial displacement at a prescribed value until the hysteresis loop stabilizes after a few cycles of loading. The loop stabilization, effects of slenderness ratio on the shape of the loop and effects of residual deformation on the load carrying capacity of the bar are discussed based on the experimental results.

## RESUME

On étudie par voie expérimentale le comportement de l'hystérésis de parois minces en acier soumises à des tensions et compressions axiales. Dans le programme d'essai toutes les éprouvettes en acier doux SS41 appuyées aux deux extrémités ont la même section de 15 x 15 mm et un degré d'allongement d'environ 40 à 160. La charge axiale répétée est appliquée centriquement et excentriquement sur l'éprouvette moyennant l'appareil de charge permettant la rotation libre aux deux extrémités de l'éprouvette. Elle est exercée sous le programme de charge contrôlant le déplacement relatif axial à une valeur prescrite jusqu'à stabilisation de la boucle d'hystérésis après quelques cycles de charge. La stabilisation de la boucle, l'effet d'allongement sur la forme ainsi que l'effet de la déformation résiduelle sur la capacité de charge de l'éprouvette sont discutés sur la base des résultats expérimentaux.

## ZUSAMMENFASSUNG

Es wird eine experimentelle Studie zur Erforschung des Hysterese-Verhaltens von Stahlblechwänden durchgeführt, die wiederholter axialer Spannung und axialem Druck ausgesetzt sind. Im Versuchsprogramm besitzen alle, an beiden Enden einfach gelagerte Probestäbe aus Flusstahl SS41 gleichen Querschnitt von 15 x 15 mm und einen Schlankheitsgrad von ca. 40 bis 160. Die wiederholte axiale Belastung wird zentrisch oder exzentrisch auf den Probestab mittels des Belastungsapparates ausgeübt, der die freie Drehung an dessen Enden gestattet. Sie erfolgt unter dem Belastungsprogramm, welches die relative Axialverschiebung bei einem vorgeschriebenen Wert kontrolliert, bis sich die Hystereseschleife nach einigen Belastungszyklen stabilisiert. Die Schleifenstabilisierung, die Wirkung des Schlankheitsgrades auf die Form der Schleife sowie der Effekt von Restdeformation auf die Belastungskapazität des Stabes werden aufgrund der experimentellen Ergebnissen diskutiert.



Leere Seite  
Blank page  
Page vide