

**Zeitschrift:** IABSE reports = Rapports AIPC = IVBH Berichte  
**Band:** 40 (1982)

**Artikel:** Evaluation methods for design alternatives  
**Autor:** Schwarz, Heinz / Steiger, Friedrich  
**DOI:** <https://doi.org/10.5169/seals-30886>

### **Nutzungsbedingungen**

Die ETH-Bibliothek ist die Anbieterin der digitalisierten Zeitschriften. Sie besitzt keine Urheberrechte an den Zeitschriften und ist nicht verantwortlich für deren Inhalte. Die Rechte liegen in der Regel bei den Herausgebern beziehungsweise den externen Rechteinhabern. [Siehe Rechtliche Hinweise.](#)

### **Conditions d'utilisation**

L'ETH Library est le fournisseur des revues numérisées. Elle ne détient aucun droit d'auteur sur les revues et n'est pas responsable de leur contenu. En règle générale, les droits sont détenus par les éditeurs ou les détenteurs de droits externes. [Voir Informations légales.](#)

### **Terms of use**

The ETH Library is the provider of the digitised journals. It does not own any copyrights to the journals and is not responsible for their content. The rights usually lie with the publishers or the external rights holders. [See Legal notice.](#)

**Download PDF:** 07.02.2025

**ETH-Bibliothek Zürich, E-Periodica, <https://www.e-periodica.ch>**

## Evaluation Methods for Design Alternatives

Méthodes d'évaluation des solutions alternatives d'un projet de construction

Bewertungsmethoden für Bauentwürfe

### Heinz SCHWARZ

Professor Dr.-Ing.  
TH Darmstadt  
Darmstadt, Fed. Rep. of Germany

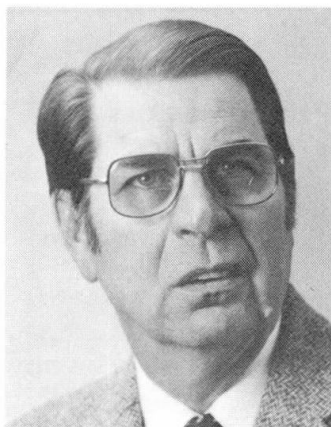

Heinz Schwarz born 1923, Civil Engineer since 1949. Different positions in structural engineering till 1969. Doctorate in 1962. Since 1970 Professor of Information Processing in Building and Civil Engineering Organisations.

### Friedrich STEIGER

Dipl.-Ing.  
TH Darmstadt  
Darmstadt, Fed. Rep. of Germany

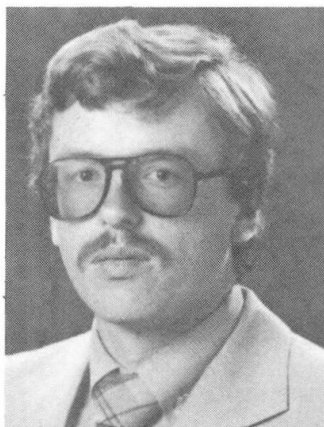

Friedrich Steiger born 1953, got his civil engineering degree at the Technische Universität Berlin in 1977. In different positions with Bilfinger + Berger Bau AG, Frankfurt. Since 1980 scientific assistant at the TH Darmstadt.

### SUMMARY

Computers may support the (structural) design engineer's work far more than simply proving safety against failure and drawing the plans. Selecting the most favourable among several competing shapes of a design object (e.g. of a structure) is one of a creative engineer's most important jobs. There are methods to support decision making under risk conditions, appropriate to this purpose, which can be easily made available by computer programs. Some fundamentals of these methods are presented and their application is illustrated by examples.

### RESUME

Le rôle de l'ordinateur dans le processus de travail de l'ingénieur dépasse largement le contrôle de la sécurité à la rupture et le dessin de plans. L'activité créatrice de l'ingénieur débouche sur l'élaboration et la confrontation de solutions concurrentes pour un même projet. Le recours, grâce à l'ordinateur, aux méthodes d'aide à la décision dans un contexte de risques est précieuse au niveau de l'évaluation. Les principes fondamentaux de ces méthodes sont présentés et leur application illustrée par des exemples.

### ZUSAMMENFASSUNG

Computer können die Arbeit der (Tragwerk-)Entwurfsingenieure erheblich weitergehend unterstützen als durch Nachweisrechnungen für die Standsicherheit und Zeichnen von Plänen. Das Auswählen der geeignetsten unter mehreren konkurrierenden Gestaltungslösungen eines Entwurfsobjekts (z.B. eines Tragwerks) gehört zu den wichtigsten Aufgaben schöpferisch tätiger Ingenieure. Es gibt Methoden zur Unterstützung des Entscheidens unter Risiko, die für diesen Zweck geeignet sind und durch Rechnerprogramme leicht verfügbar gemacht werden können. Einige Grundlagen dieser Methoden werden dargestellt und ihre Anwendung wird an Beispielen erläutert.



## 1. UNCERTAINTIES IN DESIGN DECISIONS AND THEIR REASONS

### 1.1 Introductory remarks

Computer aided design often is understood only as the generating process of geometric data which describe a three dimensional model and/or two dimensional images of the design object. Thus the design work is merely reduced to drafting. When regarding engineering work that way, structural analysis appears to be a separated task and the "structural analyst" to be the scientific trained partner of an intuitively acting "designer". From our point of view however, designing is the whole creative process of shaping and dimensioning an engineering object, and the computer should support more than the analytic and the drafting part of it.

The design process as a whole might be structured to four phases:

- Searching for appropriate solutions, which includes clarifying the requirements of the client or user
- proving the suitability of those solutions, which are going to be evaluated
- selecting the most useful solution
- preparing the construction documents

In each phase the computer may assist the designing engineer. In the first one this could be done by retrieval processes in documented material, which contains information on experiences of the engineer's organization with similar projects and/or published constructions. In the second one calculations of the design object's properties - in case of structures of its safety against failure - and drawings, which prove its suitable performance might be produced by help of computers. The third phase can be supported by computer assisted procedures of optimal decisions, if the engineer has knowledges in this field. And in the fourth phase once again drawings, but also documents in the form of texts and lists might be produced by help of computers. If computer assistance is organized optimally, the engineer might use data processing equipment to store and to manage all the data which he receives, produces and interchanges with his partners, the design process in most cases being an interactive one.

So far there exists a lack of knowledge with designing engineers in general and with structural engineers especially concerning the methodology of the first and the third phase as well as of the structuring and management of data bases. For this reason the discussions in meetings like the one to which this paper is presented should not be reduced to problems of computer usage in a narrow sense. "Informatics" should rather be understood in a broader sense. This should include methods of information processing (which means more than data processing) in all those phases of the - structural - design process, systematically ordered knowledge of which civil engineers regularly do earn neither by education nor by professional experience.

This paper as well as another contribution to this colloquium [1] present dedicated proposals to supply the want of evaluation and selection methods for competing design solutions. For this purpose we need a certain taxonomy of concepts to order the "data material" which engineers use in the process of design. This will be supplied in the following subchapter. An instrument to document and to retrieve information in the "know-how data base" of engineering organisations has been developed at our Fachgebiet Informationsverarbeitung im Bauwesen an der Technischen Hochschule Darmstadt [2, 3]. We hope that there will be an opportunity to report on this important and interesting part of engineering tools at another time.

1.2 Fundamentals of a taxonomy of design variables

In order to give as exact a description as possible of the evaluation and selection procedures' embedding in the design process we arrange the variables which the designer has to deal with, in four classes, which we term as follows:

Design variables	$h_i$
Environment-describing variables	$w_i$
Behaviour-describing variables	$e_i$
Evaluating variables	$q_i$

Design variables are those whose values describe the design object ready for construction. These include, above all, geometrical characteristics such as lengths and angles, but also material, processing and type specifying characteristics. The designer determines them in two steps. The first of these steps we term the *shaping*, the second the *dimensioning* of the design object. If we take each design variable  $h_i$  as one axis of a system of coordinates, then we can say that shaping means "spanning" an n-dimensional design space (see fig. 1) since the values of n measures and specifications have to be indicated in order to describe the object ready for constructions. This space contains a set H of points, each representing a particular combination of measure and specification values, i.e. a specific design object conceivable within the frame of the selected shape. Dimensioning then means selecting exactly one of these objects for construction.

However not every point of the design space is accorded a useful design which fulfils the established minimum requirements. Unfortunately, only in rare special cases can these requirements be expressed in the form of constraints which immediately limit the useful area in the design space. Generally they limit the permissible behaviour of the design object in its application. The characteristics for the behaviour of the design object in the application process we call *behaviour-describing variables*  $e_i$  and we attach each of them to an axis of coordinates in a so called behaviour space E. Constraints then will be represented by surfaces  $q_i(e^j) = 0$ , which limit the permissible area in the behaviour space.

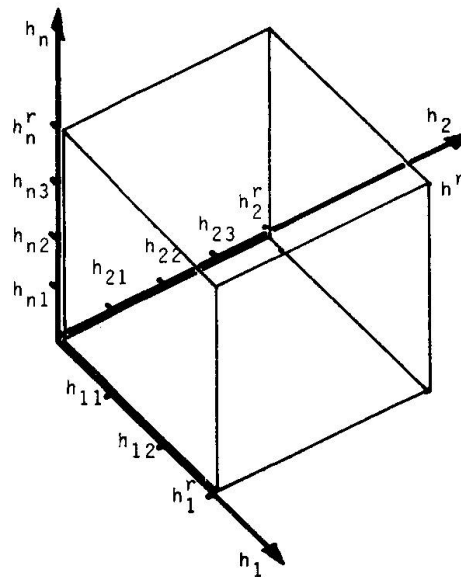

$$H_k = \{ h_{k1}, h_{k2}, \dots, h_{ks} \}$$

$$H = \{ h^i \mid h^i = (h_1^i, h_2^i, \dots, h_n^i) \} \cong \prod_{k=1}^n H_k$$

Fig. 1: Design Space

Now, the behaviour of the design object in its application does not only depend on its shape, on the material from which it is constructed, and on its dimensions, but, not least of all, on extrinsic effects to which it is subjected. We call the characteristics of these effects *environment-describing variables*  $w_i$ , whose values we attach to scales at the axes of coordinates of an environment-describing space W. Each point  $w^j = (w_1^j, w_2^j, \dots)$  in this space therefore represents a combination of environment effects which the object might be subjected to.

Systematically, each pair of points, one  $h^i$  in the design space and one  $w^j$  in the environment-describing space, is then mapped into one point  $e^j$  in the beha-

viour-describing space, which can either be situated inside the permissible region or outside of it.

We now want to illustrate the relations of concepts described up to this point by means of an example taken from structural design. Let us consider the main girder of a steel railway bridge which spans over a medium-wide opening, to be our design object. Then there is one main alternative of shapes: a welded web girder or a truss. In the case of a truss there are additional possibilities for its shape and for the framework pattern. To each of these possibilities another design space has to be attached.

To describe the shape of a web girder, the coordinate axes of the design space have to be labelled with the possible values of variables like: total girder height, thickness of chord, web plate and welding seam, dimensions and positions of stiffeners, steel grade etc. For each shape of a truss and for each framework pattern, the distances of the nodes, the specifications of the rolled profiles of the members, measures of connecting means have to be dimensioned as design variables. In any case we have to consider the specifications of rust prevention as additional design variables.

Environment-describing variables are, in this example, the dead load from the track and from the secondary girders, the live load from traffic and wind, amplitudes of temperature changes as well as characteristics of meteorological and other effects influencing corrosion. In addition to the "external" environment we have to consider the design variables of other members of the structure, which we have previously designed and which have to be compatible with the member under design, as "inner" environment. In this example the inner environment includes the elements of the track and the secondary girders with their connections to the main girder, as well as the bearings of the latter.

The variables which describe the external environment have, in contrast to the design variables, largely stochastic rather than determined values. In the case of live loads and meteorological effects this is immediately clear. Moreover in practical design processes it is usual to consider deterministic models of the environment rather than the complex and probabilistic reality. Those deterministic models are used especially for the approval of structural safety. In most countries quasi-deterministic environments of structures have been laid down in technical building codes in the form of design loads and of provisions concerning their simultaneous or alternative consideration. In our example, provisions for railway bridge loads are given for the Federal Republic of Germany by the "Vorschrift für Eisenbahnbrücken und sonstige Ingenieurbauten" (DV 804/1) of the Deutsche Bundesbahn.

From the design variables and the environment-describing variables the designer determines values of the behaviour-describing variables of his design object. In our example these include inner forces, stress and strain due to the load as well as characteristics for maintenance requirements. In the case of determined environmental effects the designer receives, for each designed solution he examines, just one set of behaviour-describing variables. Or, put another way: each solution is made up of one point  $h^i$  in the design space and one point  $w^j$  in the environment-describing space, both of them having as a common mapping one point  $e^{ij}$  in the behaviour-describing space. However, the behaviour description thus obtained is generally not exactly that, which one could observe if it were possible to apply the model environment to the structure. This is because, even in cases as simple as our own, the designer can only determine the behaviour of a further simplified model. To calculate the bearing behaviour of a structure he uses its so-called statical system as his model. Depending on the quality of the model and on that of the algorithm he uses, the behaviour of the object model will correspond more or less closely to that of the real object. The point

he has determined in the behaviour-describing space is therefore more or less far removed from that indicating the behaviour of the real object under the influence of the model environment. Normally he cannot give any exact information on size and direction of this discrepancy. It is usual to choose models which make sure, that the object behaviour will be estimated on the "safe side" but it is impossible to say how far.

When taking into account the influences of a probabilistic environment, one gets not only one point in the environment-describing, space but a "cloud of points". The probability of the appearance of each point in the cloud should be given in this case. Since each pair of points in the design space and the environment-describing space has one mapping point in the behaviour-describing space, in the latter we have a cloud of points too. In our example this situation occurs when we evaluate the behaviour-describing variables of the maintenance requirement. Only stochastic indications can be given about the influences by weather and corroding agents. When making a selection between a truss and a web-girder, the amount of maintenance requirement is relevant since these two differ not only in their different surface areas, but also in the different expenditure of maintenance work per square unit and, more importantly, in the higher risk of corrosion in the edges and corners of the connecting points of a truss.

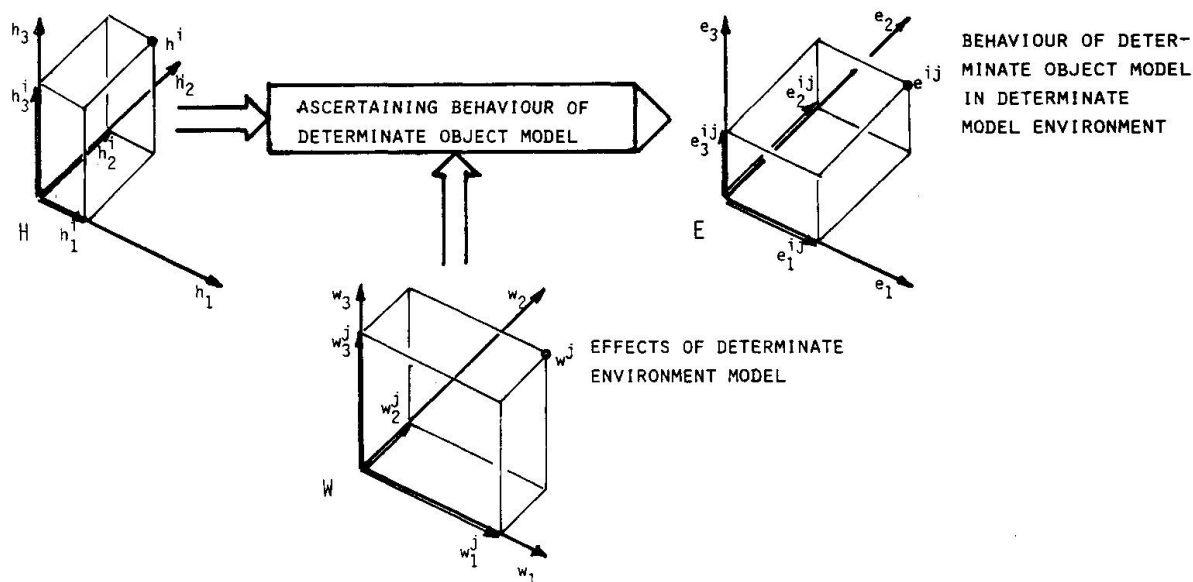

Fig. 2: Ascertaining behaviour of determinate object model in determinate model environment

The idea of mapping into the behaviour describing space in the cases of deterministic and probabilistic environment descriptions, shall be illustrated by fig. 2 and 3 respectively. In both of the two figures isometric representation and three-dimensional examples of design space, environment- and behaviour-describing spaces are used for the sake of clarity. Fig. 2 illustrates the mapping of one pair of points into one behaviour point which is shifted due to the estimating by means of an object model. Fig. 3 on the other hand is meant to show the mapping of the stochastic environment 'point cloud' into behaviour-describing point cloud, which is once again shifted.

For the comparative evaluation of alternative designs we need characteristics of those behaviour-describing variables, the values of which are relevant to evaluation. These we call *evaluating variables*. In a realistic evaluating approach more than one of these variables have to be included. Besides the price of the object - if the contractor does the evaluation on his own, the production costs respective - evaluating variables have to be defined,

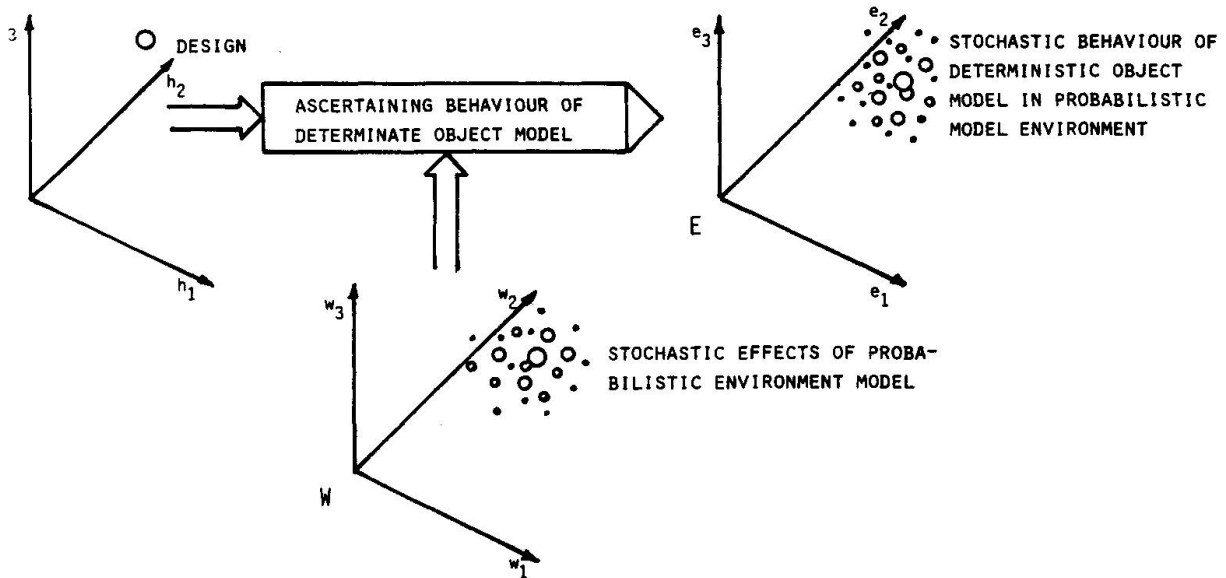

Fig. 3: Ascertaining behaviour of determinate object model in probabilistic model environment

which describe the quality of the object. With constructions the primary function of which is the bearing of load such as the railway bridge in our example, once their reliability in this function is established, mainly secondary characteristics of behaviour may be used as quality describing evaluating variables. This could be, for instance, the volume of noise due to vibrations or the intensity of elastic reactions to impulses.

To compare buildings and other constructions, the employment processes of which are more complex, construction costs and characteristics of operating quality have to be considered as competitive evaluating variables. These include in any case the maintenance and running costs, in buildings often climatic properties of rooms and envelopment, finally aesthetic features and other effects of the construction on its environment. In most cases the values of these different variables cannot be totaled by simple addition, to get a basis of comparison. This cannot be done even with construction costs on the one hand and maintenance and running costs on the other since, in the designing stage, all prices and expenses are stochastic variables. Even if the design is done by the engineering office of a contractor, the construction cost can only be roughly estimated, since local and organizational peculiarities of the construction process cannot be predicted in all details.

If the client himself, a consulting engineer or an architect does the design, they have to take into account the uncertainty of the construction market at the time of placing the orders. Besides that, the maintenance and running costs are affected by other risks as well. The maintenance costs are influenced by the construction's susceptibility to trouble and by the level of repair costs during the life time. The running costs are influenced by price developments in the energy and service market. Because of the uncertain development of the operating process these risks do not allow one to summarise expected values or other parameters of the probability distributions of the different price and cost items, if different usable design solutions differ significantly regarding their maintenance and running expenses. As to those evaluation variables which cannot be transformed directly into monetary terms, it is quite clear that it is impossible to summarize them to prices and costs in order to get one single evaluation unit.

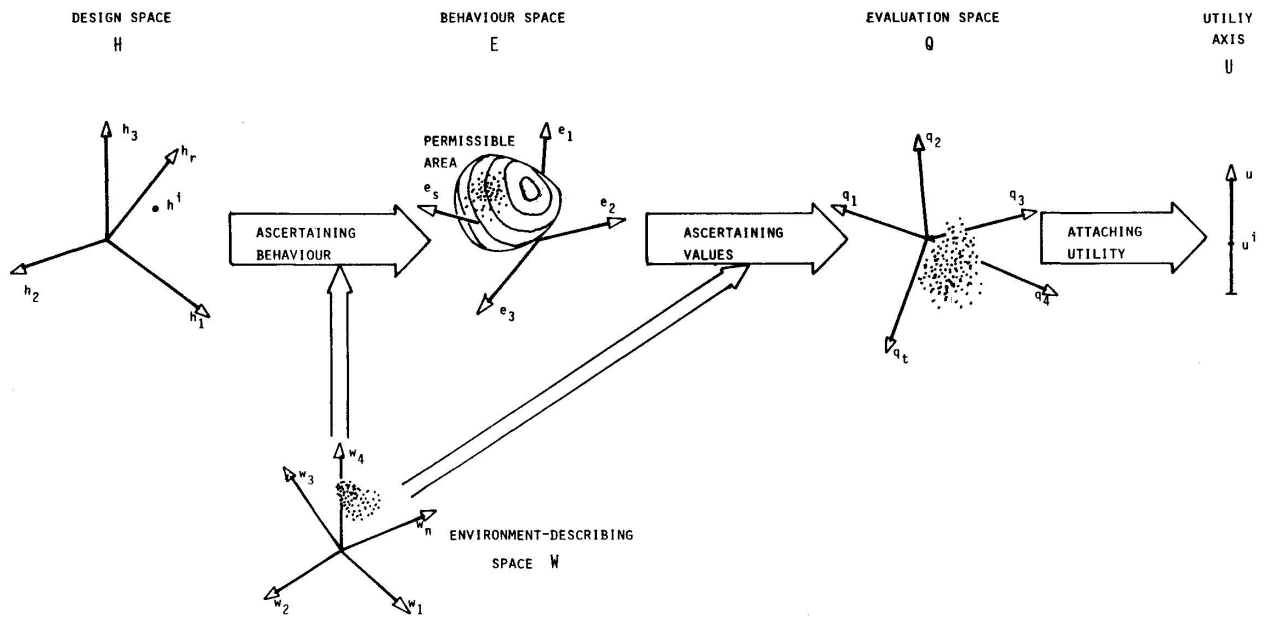

Fig. 4: Synoptical illustration of the design procedure variables' taxonomy





At first we therefore regard the different evaluation variables again as different dimensions of an evaluation space  $Q$ . To each design object  $s$  one single point  $q^s = (q_1^s, q_2^s, \dots)$  of this space is attributed, if all evaluation-variables have determined values. If at least one of them has stochastic values, we get again a cloud of points with a probability of its appearance attached to everyone.

The principles of the treatment of the evaluation problem have been prepared in the theory of rational decision-making under risk conditions in connection with the utility theory. The task is to compare a number of spatial probability distributions, i.e. to attribute each of them with a single value of a utility functional  $u(q_i, P(q_i))$ . This functional should give the highest value to that solution which holds the highest rank in the preference of the deciding subject. This rank depends on the "location" of the point cloud in the evaluation space, as well as on its density distribution. The utility functional can therefore only be formulated if the deciding subject is able to weigh up the evaluation variables against each other and if this subject additionally is willing to make mathematically convertible statements on his risk attitude.

Fig. 4 gives a synopsis of the previously presented taxonomy of design variables including the mapping from the evaluation space to the utility axis.

### 1.3 Shaping decisions and optimal dimensioning - a pair of dual problems

As we pointed out at the beginning of the previous subchapter and in the railway bridge example, *shaping* of a design object means to choose one of several competing sets of design variables - each of which spans one design space - for realization. To select one point in the chosen space - that means to assign a specific value to each design variable - we call *dimensioning*. The latter task may be supported by the use of optimization algorithms, especially if we are allowed to ignore the stochastic influences. In this case the utility functional is reduced to a determinate objective function. The problem then is to find an algorithm or a strategie which is suitable to search within the multidimensional design space. This problem is complicated by the fact, that as we already pointed out the constraints in regular cases are given by functions of the behaviour describing variables and cannot easily be mapped "back" to the design space. The mathematical definition of an optimization problem always presumes the constraints to be functions of the decision variables themselves. In the already mentioned second contribution to this symposium we describe a strategy which is suitable to dimension the members of a certain class of building systems optimally.

Neglecting the stochastic aspects will never be suitable during the shaping phase which precedes the dimensioning, especially as long as the whole design object or large parts of it are subject of the work. At this state the consequences of a shaping decision can only be roughly estimated. Thus, if we want to rationalize the evaluation and selection procedure we urgently need tools which enable us to cope with uncertainties.

We can say, that shaping decisions and optimal dimensioning are dual problems, not in a strict mathematical sense, but regarding the conditions under which these problems have to be solved. When we have to select one of different shapes we must not go into the quantitative details of the object's properties as long as we are sure that there is at least one feasible point in the respective design space. But we need a basis to estimate parameters of the relevant evaluation variables' probability distributions attached to that space. In other words we have to concentrate on the rightmost of the "mappings" shown in fig. 4. When on the other hand searching for that point in a design space which delivers the

highest value of the utility function we must be able to establish an appropriate quantitative model of the objects behaviour. If possible we try to divide the object into small parts - to decompose the optimization problem as we say. Thus we can hope that in most cases only one of the evaluation variables depend on variations of the regarded part's design variables and that we are prepared to establish a determinate objective function describing this interdependence. So we concentrate on the mappings shown in the left part of fig.4.

## 2. A FEW BASIC CONCEPTS OF UTILITY THEORY AND DECISION ANALYSIS

In this chapter we just report some assumptions, ideas and proposals, given by distinguished authors in the field of decision making. Especially we use the concepts of Ronald A. Howard and the school of thought at Stanford Research Institute [4, 5]. An excellent tutorial is given by John W. North in [6].

Usually there is no -or only an insufficient- data-base to derive a probability distribution of evaluating variables. The importance of uncertainty is revealed when we realize that decisions in situations where there is no random element can usually be made with little difficulty. Only when we are uncertain about which of a number of possible outcomes will occur do we find ourselves with a real decision problem.

One of the key-factors in the decision making process is the establishment of the value to be attached to each of the various outcomes of a decision. When faced with two completely specified future sequences of profits, costs or other consequences, the decision maker must be able to say which he prefers and to state his preference in quantity terms. In business problems the desirability of any outcome will usually be measured in terms of money, either directly in costs or implicitly assigned as valuing customer's goodwill and employee's satisfaction.

The mathematical theory concerned with assessment of value is called the utility theory. Although this theory is not so widely known as probability theory, it is based on probability theory and on some additional axioms. The first of these axioms, for example, is the axiom of transitivity. This axiom states that if the decision maker prefers outcome A to outcome B and if he prefers outcome B to outcome C, then he must prefer outcome A to outcome C. The theory will not be useful to a person who does not subscribe to this tenet.

Since the domain of utility theory is evaluating decision alternatives with uncertain outcomes, most of the axioms deal with the handling of probability distributions of outcomes. Usually propositions with uncertain outcomes are called "lotteries". A user of decision analysis must be willing to compare different lotteries with each other. Furthermore he has to assign to each lottery his personal "certain equivalent". This is the value of a certain outcome, which he regards equivalent to the participation in the lottery. The possible outcomes of a lottery are called "prices".

We shall soon show that an individual whose preferences satisfy the utility axioms may encode those preferences in a utility function that assigns a utility number to every price. This utility function has two important properties:

- The utility of any lottery is the expected utility of its prices.
- If the decision maker prefers one lottery to another then it must have the higher utility.

A so called Bernoulli Utility Function, which realizes these properties enables



the decision maker to express his risk preferences exactly and logically. We can think of the utility function as a "preference thermometer". The utility numbers have no meaning in themselves; they serve only to compare the desirability of lotteries. Because of the linear properties of expectation, we can multiply the utility function by any positive number and add constants to all utilities without changing the preference they express. If all the prices are measured in terms of a commodity, then the utility function can be expressed by a curve that assigns a utility number to every value of the commodity. If, furthermore, this commodity is such that more ( or less ) is always better, for example money ( or costs ) then the utility curve will be monotonically increasing.

How can an individual establish a utility curve of the Bernoulli type for himself or for his organisation? This we shall show by an example.

Let us suppose that we wish to assess some individual's utility curve for amounts of the order of less than hundred DM. We might begin by assigning the utility 0 to the amount zero and the utility 1 to the amount of 100 DM,

$$u(0) = 0 ; u(100) = 1$$

We may now use the so called equiprobable lottery method and investigate the shape of the curve within the ( 0, 100 ) region. We could ask him : "What is your certain equivalent to an equiprobable lottery on zero and 100 DM ?" and he might answer: "25 DM". This causes

$$\begin{aligned} u(25) &= 1/2 u(100) + 1/2 u(0) \\ u(25) &= 0.5 \end{aligned}$$

Next we ask him for his certain equivalent for an equiprobable lottery on 0 and his answer to the first question, 25 DM. If he replies, "10 DM" then there follows

$$\begin{aligned} u(10) &= 1/2 u(25) + 1/2 u(0) \\ u(10) &= 0.125 \end{aligned}$$

At last we ask him for his certain equivalent to an equiprobable lottery on 25 DM ( his first answer ) and 100 DM. He then might set his certain equivalent at 40 DM and we state

$$\begin{aligned} u(40) &= 1/2 u(100) + 1/2 u(25) \\ u(40) &= 0.75 \end{aligned}$$

These figures will allow us to determine a rough path of the curve. It is plotted in figure 5, curve 1. We see that this utility curve is generally concave downward, indicating that the individual is risk averse ( in this region of values ). Curve 2 and 3 in figure 5 show the utility curves of a risk indifferent and a risk friendly decision maker respectively. With the described method we also will be able to value different lotteries. For example:

$$\begin{aligned} L1 &: ( 0.3, 80 \text{ DM}; 0.2, 70 \text{ DM}; 0.5, 0 \text{ DM} ) \\ L2 &: ( 0.1, 90 \text{ DM}; 0.3, 50 \text{ DM}; 0.6, 20 \text{ DM} ) \end{aligned}$$

describe two lotteries, the first of which offers 80 DM with a probability of .3 70 DM with a probability of .2 and nothing with a probability of .5, the second one may now be interpreted by the reader. In case that the decision maker is risk indifferent the utilities are equal to the expected values:

$$\begin{aligned} u(L1) &= 0.3 \times 80 + 0.2 \times 70 + 0.5 \times 0 = 38 \text{ DM} \\ u(L2) &= 0.1 \times 90 + 0.3 \times 50 + 0.6 \times 20 = 36 \text{ DM} \end{aligned}$$

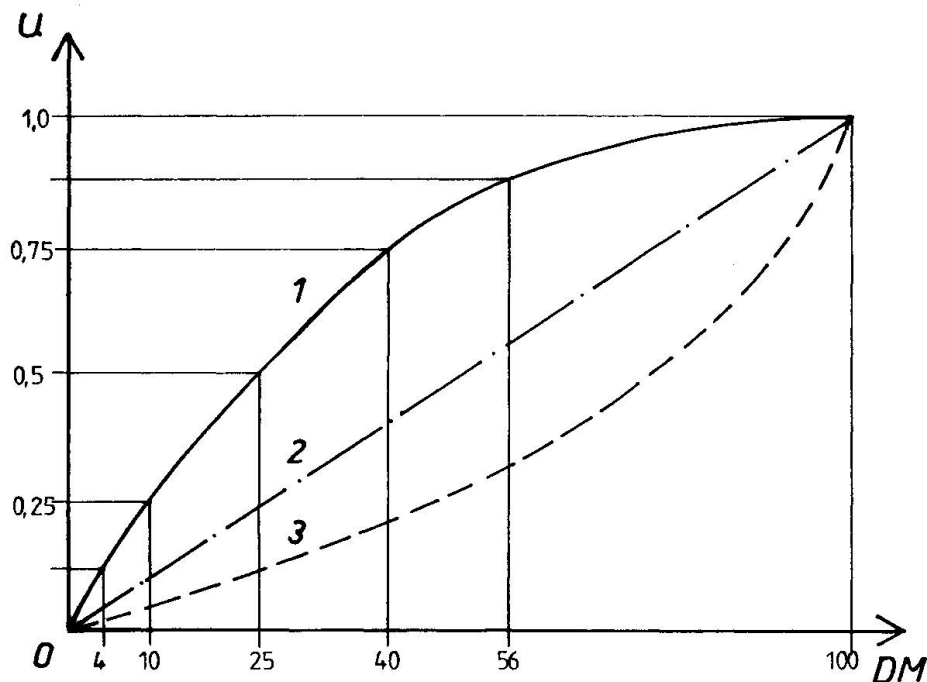

Fig. 5: Examples of utility curves

and consequently he would prefer the first one. Should he not be indifferent, but risk averse according to curve 1 in fig. 5, then his preferences follow from the different utility values of the prices:

$$\begin{aligned} u(80 \text{ DM}) &= 0.92; & u(70 \text{ DM}) &= 0.875; & u(0 \text{ DM}) &= 0 \\ u(90 \text{ DM}) &= 0.96; & u(50 \text{ DM}) &= 0.79; & u(20 \text{ DM}) &= 0.39 \end{aligned}$$

Hence

$$\begin{aligned} u(L1) &= 0.3 \times 0.92 + 0.2 \times 0.875 + 0.5 \times 0 = 0.44 \\ u(L2) &= 0.1 \times 0.96 + 0.3 \times 0.79 + 0.6 \times 0.39 = 0.55 \end{aligned}$$

and now the decision maker prefers L2 to L1.

An objection to the demonstrated method might be, that there is a significant difference between answering questions on certain equivalents and making momentous business decisions. But the method will have an important learning effect. At least it may show the sensitivity of a decision to the risk attitude of the decision maker, when it will be applied repeatedly with changing utility curves. For this purpose a quadratic interpolation between 3 values as demonstrated in the examples of chapter 5 might be a sufficient approximation of utility curves.

It shall be emphasized that it is principally possible to establish a utility function concerning other continuous varying measures of evaluation variables' outcomes, e.g. load bearing reserves of a structure. By this means we can produce a certain equivalent of each evaluation variable in a multi dimensional evaluation space and thus reduce the "point cloud", attached to each shape of a design object to one representative point. But we have to admit that this reduction implies several problems concerning the question in what cases a spatial probability distribution may be represented by the union of its axial distributions. Here is not the place to deal with these questions and therefore we shall reduce the following considerations to the case of one single evaluation variable, which in most cases will be the price or the production costs of the object.



### 3. ESTIMATING THE RISK IN EVALUATING VARIABLES BY BETA DISTRIBUTIONS

Utility function and decision analysis can only be employed successfully to shaping decision problems if we have at hand adequate probability distributions of evaluating variables. In most practical cases data bases from which those distributions could be derived are not yet available. We therefore have to estimate the outcome of the evaluating variables like we are used to do all the time, whenever we make a decision.

But instead of estimating just one value of every variable which we could assume to be a determined one in a deterministic evaluation model we have to estimate as much parameters as necessary to define a probability distribution of the type we want to use. In case we want to describe the possible outcome of a variable by a continuous symmetric normal distribution we need two establish two parameters, e.g. the mean and the variance. But this will not be easy to do if we are not very experienced in the matter of statistical estimation.

Perhaps a designer will rather be able to estimate a lower and an upper limit as well as the most probable value of an evaluating variable. In this case he might establish the so called  $\beta$ -distribution, which is well known from PERT (program evaluation and review technique, a special method of network planning technique) [7]. This distribution has several important advantages for practical purposes as we are going to show.

We call the three previously mentioned values of an evaluating variable

- q pes - the most unfavourable value
- q med - the most probable value
- q opt - the most favourable value

To the  $\beta$ -distribution a density function is attached which is defined by

$$f(q) = \frac{1}{F} (q - q \text{ pes})^\alpha (q \text{ opt} - q)^\gamma$$

within the range

$$q \text{ pes} < q < q \text{ opt}$$

This function fulfils the presuppositions of the probability arithmetic with

$$F = \int_{q \text{ pes}}^{q \text{ opt}} (q - q \text{ pes})^\alpha (q \text{ opt} - q)^\gamma dq$$

Furthermore

in case  $\alpha \neq 0$  and  $\gamma \neq 0$

we have  $f(q \text{ pes}) = f(q \text{ opt}) = 0$

and in case

$$\frac{\alpha}{\alpha + \gamma} = \frac{(q \text{ med} - q \text{ pes})}{(q \text{ opt} - q \text{ pes})} = \frac{\delta q}{\Delta q} \quad \left. \frac{df}{dq} \right|_{q \text{ med}} = 0$$

We may use then  $\alpha + \gamma$  as a parameter to vary the "slimness" of the density curve.

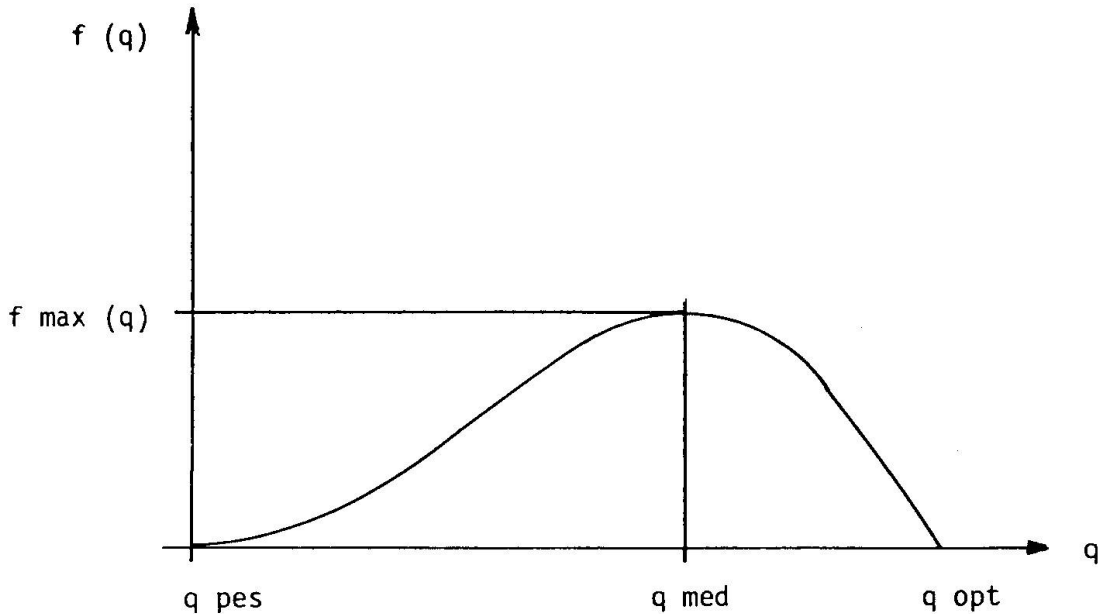

Fig. 6: A typical density curve of a  $\beta$ -distribution

Fig. 6 shows a typical image of a density function of that type. For practical applications the fact is interesting, that the expected value of such a distribution may easily be calculated by

$$\frac{q \text{ exp} - q \text{ pess}}{\Delta q} = \frac{\alpha + 1}{\alpha + \gamma + 2}$$

From the point of view of utility theory now such a density function attached to the values of an evaluating variable represents a lottery with a continuous spectrum of prices. Hence its certain equivalent may be obtained by integrating the product of the density ordinates and the respective utility ordinates

$$U(f(q)) = \int_{q \text{ pes}}^{q \text{ opt}} f(q) u(q) dq$$

With this type of calculation structural engineers are quite familiar. It is very easy to write a small computer program which evaluates a utility function, a density functions of the  $\beta$ -type, multiplies the respective values and integrates numerically over the range from  $q \text{ pes}$  to  $q \text{ opt}$ .

This can be done with the of the evaluating variables' density functions of all the competing shapes of a design object, using a utility function, which attaches "zero" to the most unfavourable of all pessimistic and "one" to the most favourable of all optimistic outcome estimations. Figure 7 gives a flow diagram which orders the designer's and the computer's actions together.

Obviously this procedure will not bring additional information in cases where all of the three estimated values of one distribution are better than the respective ones of an other. Every risk attitude will come up with the first mentioned solution having a higher rank in the preference order than the second one. But there are many practical cases where the most probable values of several shapes are equal or at least adjoining. If there are larger differences in the optimistic and/or pessimistic estimations, these will be the cases in which the proposed method will be most helpful. Two examples will show similar cases and may illustrate the advantages of the procedure.

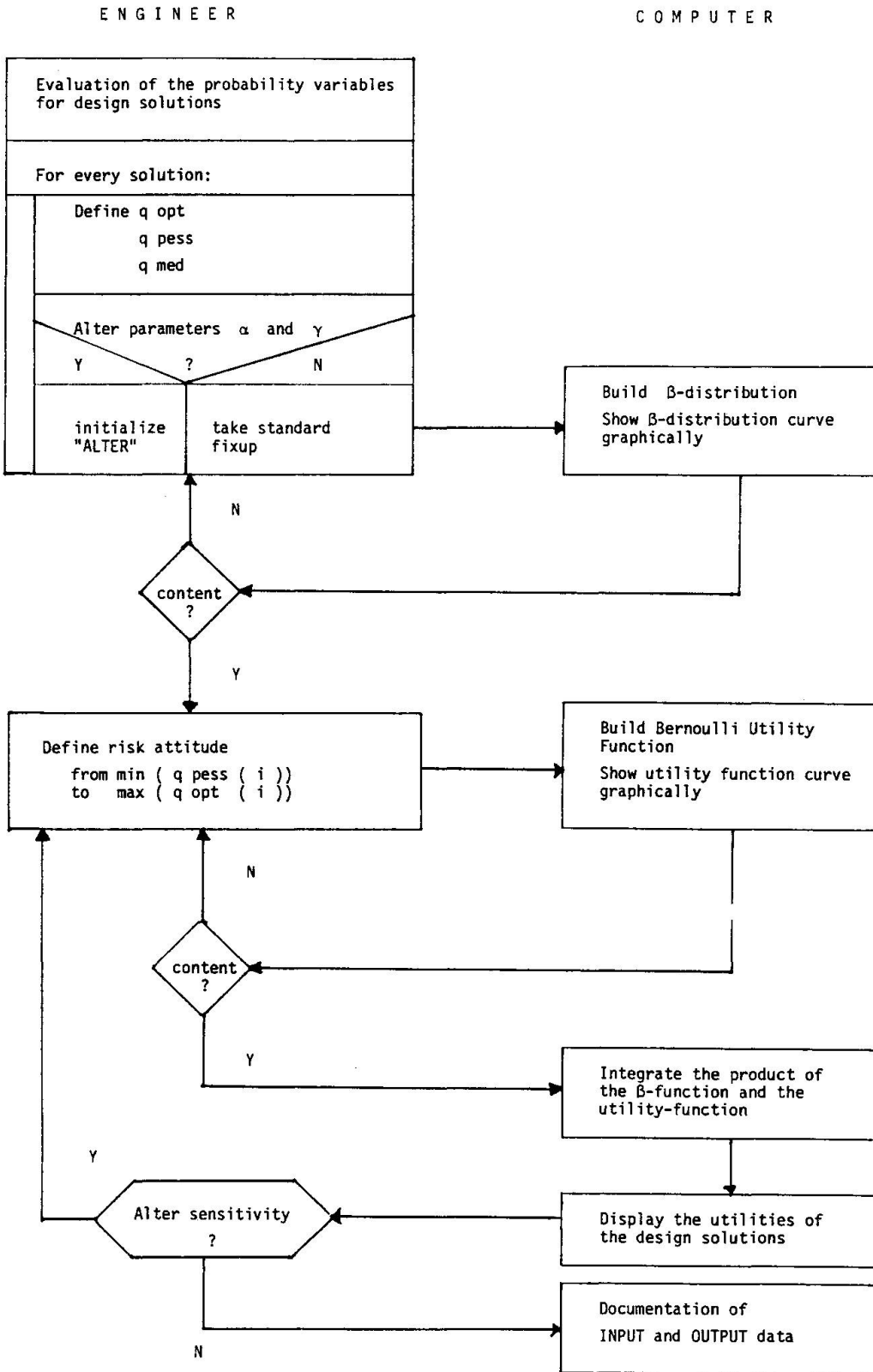

Fig. 7: Flowchart of an interactive process to value design solutions

4. TWO EXAMPLES

4.1 Comparing two concrete bridge structures

During the design phase of a bridge structure there shall be decided whether the cross section of the prestressed main girder shall have the form of a hollow beam like figure 8.1 or of T-beams like figure 8.2. Due to the girder's span the estimated most probable values of the price are equal.

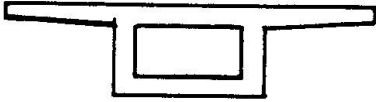

Fig. 8.1: Hollow beam cross section      Fig. 8.2: T-beam cross section of a bridge girder

q pes = -1.700 DM/m<sup>2</sup>  
 q med = -1.300 DM/m<sup>2</sup>  
 q opt = -1.100 DM/m<sup>2</sup>

q pes = -1.500 DM/m<sup>2</sup> carriage way area  
 q med = -1.300 DM/m<sup>2</sup>  
 q opt = -1.200 DM/m<sup>2</sup>

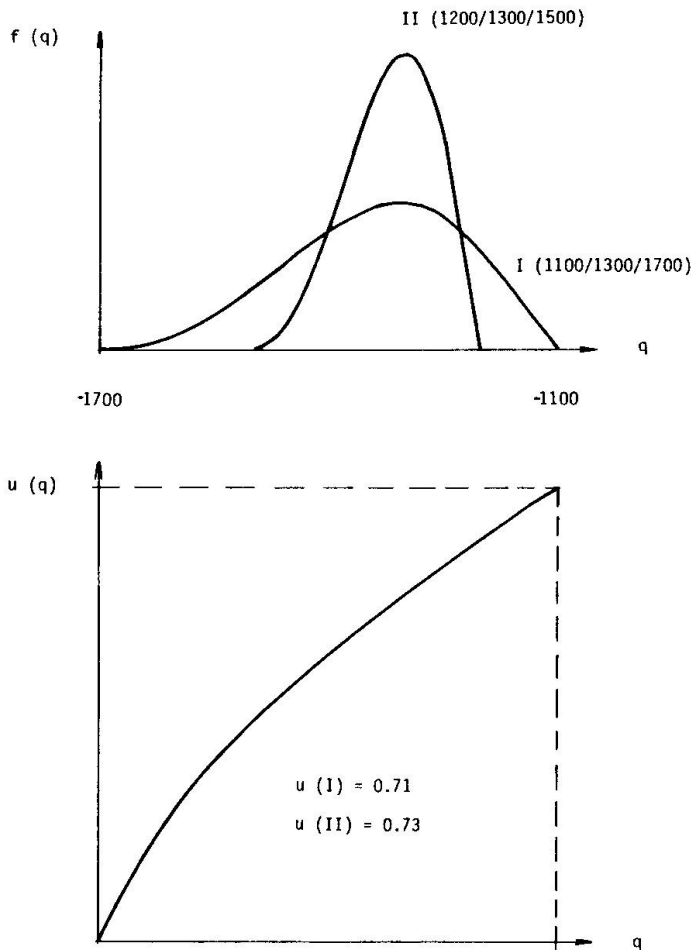

Fig. 8.3: Density and utility curves to the bridge example



We assume, that - like this will be the case in most real situations - the decision maker is risk averse. The measurement of his risk aversion is that he wants to reduce the price of a equiprobable lottery by 15% of the total difference against the mean, as shown in the utility curve of fig. 8.3, which is drawn by a quadratic interpolation between the points  $(-1.700;0)$ ,  $(-1.550;0.5)$  and  $(-1.100;1.0)$ .

A person or institution with the established risk attitude should prefer the T-beam solution, since the integration delivers

$$u(1) = 0.71$$

$$u(2) = 0,73$$

#### 4.2 Comparing two shapes of a building structure

Let us assume that we have to decide whether the framed structure of a multi story building should be assembled from prefabricated elements or cast in situ. The most probable values of the prices shall once again be estimated to be equal. But the difference between the pessimistic and the optimistic outcome estimation may be much higher with the prefabricated structure than with the other one. So we get for the structure

prefabricated

q pes = -200 DM/m<sup>3</sup>  
 q med = -150 DM/m<sup>3</sup>  
 q opt = -100 DM/m<sup>3</sup>

cast in situ

q pes = -170 DM/m<sup>3</sup> (price per unit  
 q med = -150 DM/m<sup>3</sup> cubic capacity  
 q opt = -130 DM/m<sup>3</sup> carcase only)

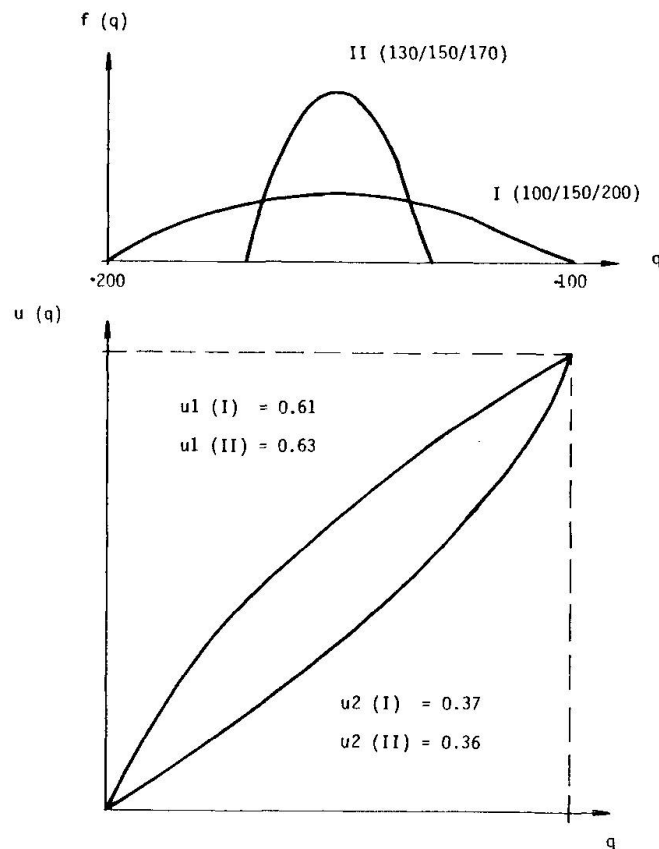

Fig. 9: Density and utility curves to the building example

Both these distributions are obviously symmetric and have equal means. Hence the decision depends on the designer's (or employer's) risk attitude. If he will be

risk averse as represented by the upper utility curve in fig. 9 then he will decide in favor of casting in situ. Should he be willing to take a risk - hoping actually to come out with a lower price - then he might prefer the prefabricated solution.

The calculated utility values are

$$\begin{aligned}u(\text{pref,av}) &= 0.61 \\u(\text{pref,fr}) &= 0.37\end{aligned}$$

$$\begin{aligned}u(\text{situ,av}) &= 0.63 \\u(\text{situ,fr}) &= 0.36\end{aligned}$$

## 5. CONCLUSION

This contribution should emphasize to the fact, that computers might assist the (structural) designing engineer far more than by analysing the object's properties and by drawing some plans. Their efficiency allows him to investigate and compare a greater number of variants and therefore he also needs assistance with the selection and optimization procedure. One of the two main application problems of the previously described methods, the lack of price and cost data may be solved by computer assistance too. It will be possible to assemble those data in data bases and to maintain these bases by data base management software. And to solve the second one of the application problems, computers may contribute by a "training service": By frequently repeated, controlled attempts designers and employers can learn to express their risk attitude properly in terms of their certain equivalent.

## 5. REFERENCES

- [1] LESNIAK, Z.K.; SCHWARZ, H.: A Method for Optimum Design of Building Systems. Contribution to the IABSE Colloquium on "Informatics in Structural Engineering", Bergamo 1982
- [2] SCHWARZ, H.; EBELING, G.; KREIBICH, F.; KRIEGSMANN, K.; MERTEN, C.; MÜLLER, F. Datenbasis Hochbau. CAD-Berichte Nr 140 Hrsg. Kernforschungszentrum Karlsruhe. 1979
- [3] SCHWARZ, H.; MÜLLER, F.: INFOSBAU sichert die Informationsversorgung. In: Beratende Ingenieure, Zeitschrift des Deutschen Consulting. Hrsg. Verband Beratender Ingenieure VBI, Essen. Nr. 5 1980.
- [4] HOWARD, R.A.: Decision Analysis: Applied Decision Theory. Presented at the Fourth International Conference On Operations Research, Boston 1966.
- [5] HOWARD, R.A.: Risk Preference. Stanford Research Institute, 1970.
- [6] NORTH, D.W.: A Tutorial Introduction to Decision Theory. In: IEEE Transactions on Systems Science and Cybernetics, Volume SSc-4, Number 3, New York 1968.
- [7] WEBER, K.: Planung mit der "Program Evaluation and Review Technique"(PERT). In: Industrielle Organisation Nr. 32, Zürich 1963.

Leere Seite  
Blank page  
Page vide