

# Composite steel-concrete connections in stub-girder floor system

Autor(en): **Hosain, M.U. / Leung, Kwan-tak**

Objektyp: **Article**

Zeitschrift: **IABSE reports = Rapports AIPC = IVBH Berichte**

Band (Jahr): **48 (1985)**

PDF erstellt am: **22.07.2024**

Persistenter Link: <https://doi.org/10.5169/seals-37466>

## **Nutzungsbedingungen**

Die ETH-Bibliothek ist Anbieterin der digitalisierten Zeitschriften. Sie besitzt keine Urheberrechte an den Inhalten der Zeitschriften. Die Rechte liegen in der Regel bei den Herausgebern.

Die auf der Plattform e-periodica veröffentlichten Dokumente stehen für nicht-kommerzielle Zwecke in Lehre und Forschung sowie für die private Nutzung frei zur Verfügung. Einzelne Dateien oder Ausdrucke aus diesem Angebot können zusammen mit diesen Nutzungsbedingungen und den korrekten Herkunftsbezeichnungen weitergegeben werden.

Das Veröffentlichen von Bildern in Print- und Online-Publikationen ist nur mit vorheriger Genehmigung der Rechteinhaber erlaubt. Die systematische Speicherung von Teilen des elektronischen Angebots auf anderen Servern bedarf ebenfalls des schriftlichen Einverständnisses der Rechteinhaber.

## **Haftungsausschluss**

Alle Angaben erfolgen ohne Gewähr für Vollständigkeit oder Richtigkeit. Es wird keine Haftung übernommen für Schäden durch die Verwendung von Informationen aus diesem Online-Angebot oder durch das Fehlen von Informationen. Dies gilt auch für Inhalte Dritter, die über dieses Angebot zugänglich sind.

## Composite Steel-Concrete Connections in Stub-Girder Floor System

Connection par goujons des poutres mixtes de planchers

Schubverbindungen von Stahlträgern mit Betondecken mittels Stahlprofilstücken

### M. U. HOSAIN

Professor  
University of Saskatchewan  
Saskatoon, SK, Canada

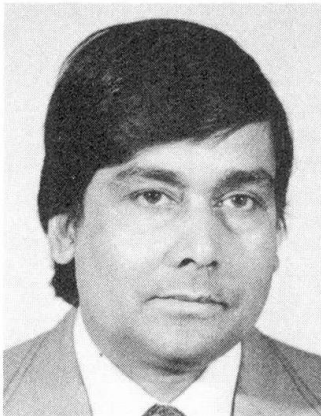

M.U. Hosain, born in Calcutta, received his M.Sc. and Ph.D. degrees in Canada. After two years with consulting firms, he joined University of Saskatchewan in 1969. His research interests are in the areas of steel structures and computer aided design and analysis.

### K. T. LEUNG

Graduate Student  
University of Saskatchewan  
Saskatoon, SK, Canada

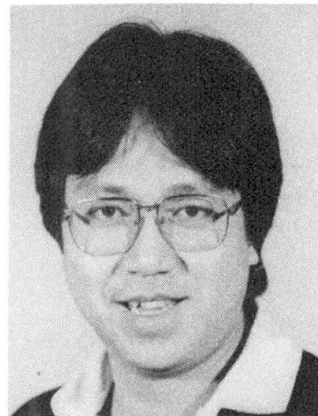

Kwan-tak Leung, who was born in Hong Kong in 1954, received his B.E. and M.Sc. degrees from the University of Saskatchewan in 1980 and 1985, respectively. Currently, he is conducting doctoral research on the stub-girder system in the same University.

### SUMMARY

The composite connection between the steel stub and the concrete slab is the weakest link in a stub-girder floor system. This paper briefly summarizes the investigations conducted in this area and identifies the specific areas which are in need of further research.

### RÉSUMÉ

La connection entre le goujon et la dalle de béton constitue le point faible d'une poutre mixte de plancher. Cet article résume les recherches faites sur cette question et montre les problèmes qui devront faire l'objet de futures investigations.

### ZUSAMMENFASSUNG

Die Verbundverbindung zwischen Stahlstückdübel und Betonplatten ist das schwächste Glied in einem Stahlträger-Betondecken-Verbundsystem. Dieser Beitrag fasst die Untersuchungen auf diesem Gebiet kurz zusammen und zeigt die speziellen Gebiete auf, in denen weitere Forschungen nötig sind.



## 1. INTRODUCTION

The use of stub-girder floor system was first reported by Joseph Colaco [5] in 1971. As shown in Fig. 1, a stub-girder consists of a steel beam and a reinforced concrete slab separated by a series of short rolled steel sections called 'stubs'. The inherent openings between the girders and the concrete slab lend the system its unique ability to integrate with mechanical, electrical, sprinkler and ceiling systems.

The stub-girder system has been used in numerous buildings in North America [4,10] but an established design method is still lacking. One area which requires further investigation is the shear failure mechanism at the stub-concrete slab interface which is probably the weakest link in a stub-girder system. Recent tests and studies on stub-girder systems or partial assemblages have provided valuable answers but much more work is needed. The over-all problem is much too involved and complicated. It would require comprehensive testing and theoretical analysis not only by a handful of researchers in North America but also by others in Europe and elsewhere. Thus, the main objective of this paper is to briefly summarize the research projects that have been completed thus far and identify the specific areas which would require further investigation.

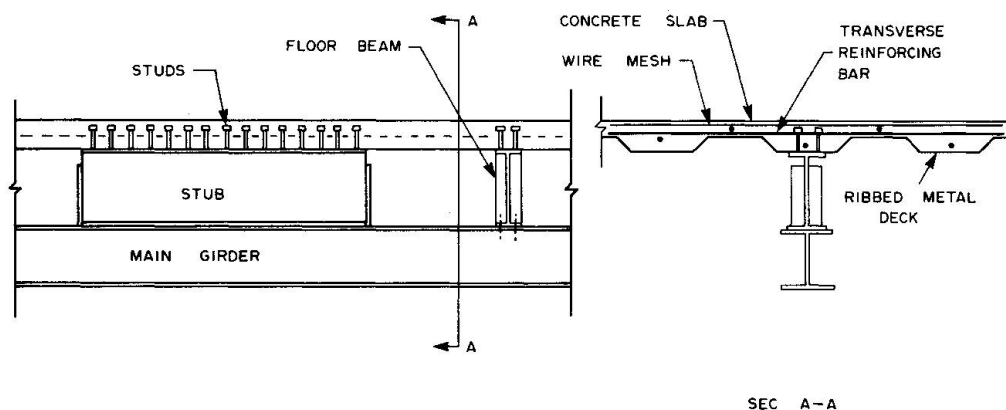

Fig. 1 Stub-Girder Floor System

## 2. PROPRIETARY RESEARCH

Early investigations on the stub-girder system were proprietary in nature [10].

In 1972, Colaco [5] reported the results of load tests on a stub-girder which was similar to those used in One Allen Center in Houston, Texas. The load test, which was conducted at the test facilities of Granco Steel Products Company in St. Louis, was designed to simulate the actual loading condition of the floor system. A factor of safety of 2.2 on the design load was obtained for the test. Failure was triggered by web crippling at the exterior end of one of the end stubs, followed by the crushing of the concrete slab "at the edge of the first stub piece approximately 7 ft.-0 in. from the support".

Prior to the construction of the First International Building in Dallas, the

consulting structural engineers (Ellisor & Tanner, Inc.) conducted load tests on two full size specimens [9]. The first test was carried out in December 1971 by Inryco Research and Development Company [12] at the University of Wisconsin, Milwaukee. The observed ultimate load exceeded 2.54 times the design load. On completion of the test, stress flaking was observed "on the web of the south spacer and on the weld between this spacer and W14x48 girder. In addition, one of the welds which attached a web stiffener to this spacer was broken". The second test was conducted in January, 1972 by H.H. Robertson Co. of Ambridge, Pennsylvania. The design ultimate load was 1.7 times the service load. The test report [18] stated that: "Prior to failure, two loud noises occurred and at 1.86 times the design load, failure occurred in the stud cluster adjacent to the west support causing loss of composite interaction".

### 3. NON-PROPRIETARY RESEARCH

The first non-proprietary investigation of stub-girders was started in 1977 at the University of Saskatchewan by the senior author and graduate student W.K. Lam. The M.Sc. thesis project involved tests on ten small size stub-girders. Seven specimens had solid concrete slabs as shown in Fig. 2. In the other three, the slab was placed on ribbed metal deck. Results of this study [14] indicated the susceptibility of stub-girders to longitudinal shear failure. This is due to the shorter length of concrete slab available for shear transfer, the presence of prying forces and the use of ribbed metal deck. This mode of failure was next reported by Buckner et al. [2] in an 8 metre stub-girder with a solid slab. Based on test results, Buckner et al. proposed a method of estimating the transverse reinforcement required and recommended that at least half of this reinforcement should be placed in the bottom half of the slab. However, a stub-girder invariably utilizes a ribbed metal deck which prevents the placement of transverse reinforcement in the bottom half of the slab.

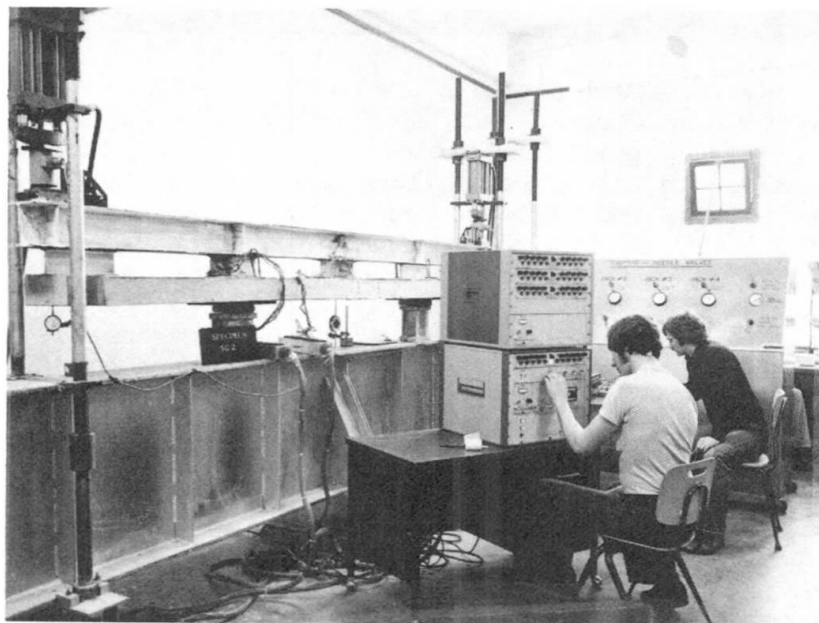

Fig. 2 Test Set-up Used for Small Size Stub-Girders

A research project on stub-girders was carried out at the University of Alberta and reported by BJORHOVDE and ZIMMERMAN [1,22]. The research consisted of push-off tests of five full-scale stub assemblages, followed by a theoretical evaluation and testing of a full-scale stub-girder. The stub assemblages failed in a "shear and compression" mode at loads below the design level. Failure of the full-scale stub-girder was caused by a combination of stud shear and stud pull-out at the end stubs. The observed ultimate load exceeded the design ultimate load by 34%. Measured horizontal shear forces were not reported for the test, but the estimated value at failure was 1820 kN based on an elastic Vierendeel analysis proposed by the researchers. This would produce an average shear force per stud of only 61 kN at failure, well below the factored shear resistance of 97 kN, determined in accordance with CAN3-S16.1-M78 [21]. The researchers recommended further evaluation of concrete slab reinforcement requirements.

Concurrently another program was instituted at the University of Saskatchewan and reported by GOSSSELIN and HOSAIN [7]. The research project involved the testing of two full size stub-girders with slabs on ribbed metal decks. As the first phase of a continuing investigation, this study considered the special case of stub-concrete connections with headed studs arranged in a single line. In both beams, failure was caused by the longitudinal splitting of the concrete slab over the end stubs. The average ultimate shear load per stud was determined to be 26.7 kN for Specimen 1 and 33 kN for Specimen 2. The maximum capacity per stud that can be developed in shear, based on CAN3-S16.1-M78 for conventional composite design, is 64.2 kN for the high strength concrete used. The placement of lateral reinforcement in both tests was ineffective in resisting concrete splitting and shearing [8]. Though the transverse reinforcement area supplied was sufficient to satisfy the CSA requirement (transverse reinforcement ratio = 0.005), the configuration of the metal deck prevented placement in the bottom of the slab as required by the CSA.

In the second phase [13] of the above research program, three full size specimens (K-1, K-2 and K-3), conforming to a typical office floor loading and layout, were tested to failure. The main experimental parameter was the difference in the amount and configuration of the transverse slab reinforcement. The observed ultimate load on the stub-girders exceeded the design ultimate load by 45%, 14% and 21% respectively for K-1, K-2 and K-3. The specimens were very stiff and would meet normal deflection requirements under service loads. In all cases, failure involved crushing of the slab over the interior end of the end stub accompanied by a shear/splitting failure in the slab over the length of the end stub. Straight transverse reinforcing bars in addition to temperature and shrinkage reinforcement, had little effect on the stub-girder capacity. The incorporation of a wide concrete flute along the slab centreline, together with the use of bent transverse reinforcing bars significantly increased the ultimate capacity and improved the ductility of the stub-girder. The average shear load per stud at failure was calculated to be 62.0 kN, 50.7 kN and 51.7 kN for specimens K-1, K-2 and K-3 respectively compared to an ideal value of approximately 97 kN [21] based on the shear failure of the stud itself. In one of the three specimens, the fillet welds along the interior end of the end stub showed signs of distress just prior to the attainment of elastic limit load and required repair work.

The third phase of the research project involved the testing of one full size specimen (K-4) and three full size partial assemblages [11]. Specimen K-4 was

identical to specimen K-3 except that the headed studs were welded through the metal deck. Fig. 3 shows the test set-up used for the full scale test. Specimen K-4 exhibited a 6% higher ultimate load than that of specimen K-3. The increase may be attributed to the weld-thru-deck installation used for the headed studs. The failure mode involved crushing of the slab over the end stub as shown in Fig. 4. The average shear load per stud at failure was 54.48 kN.

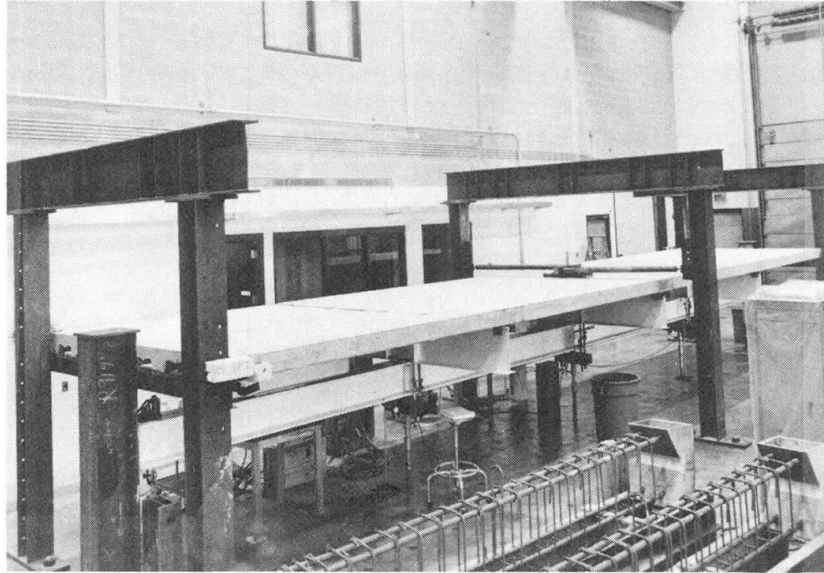

Fig. 3 Test Set-up Used for Full Size Tests

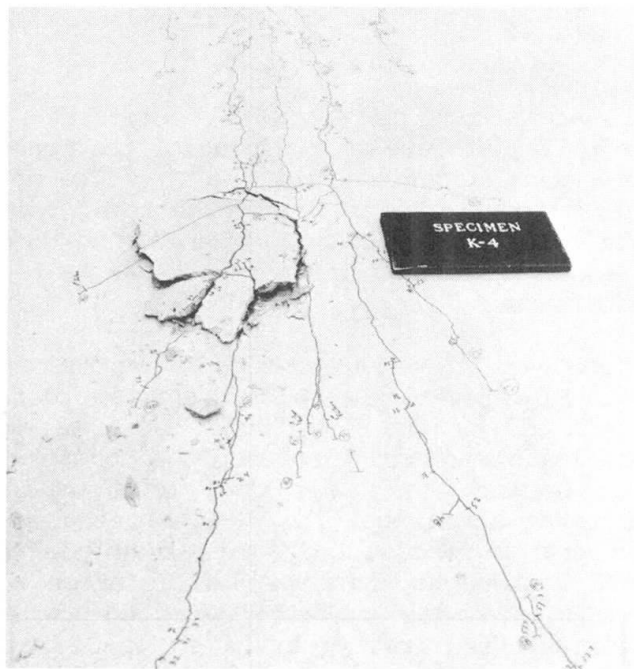

Fig. 4 Concrete Failure



Push-off tests on the three partial assemblages (T-1, T-2 and T-3) reproduced failure patterns similar to that observed in specimen K-4. Once again, straight transverse reinforcement in addition to the wire mesh had only marginal effect on the stub-girder capacity although the bent bars were more effective. Specimen T-3 with the bent transverse bars recorded a 12% increase in ultimate strength compared to specimen T-2 which did not have additional transverse bars. The ribbed metal deck, clear cover and longitudinal reinforcement prevented the placement of the reinforcement in the bottom half of the slab where it may be more effective.

The above-mentioned full scale tests were all carried out on isolated stub-girders. It has recently been reported [17] that an isolated stub-girder is more susceptible to longitudinal shear failure than a girder in a stub-girder system. Researchers at the Louisiana State University reached this conclusion after conducting experiments on an isolated stub-girder model and on a scale model of a two-bay stub-girder floor system.

As part of a M.Sc. thesis project, T.W.K. Chan [3] carried out push-off tests on 42 stub-slab assemblages to simulate the behaviour observed in the full-size tests of stub-girders. This investigation led to the formulation of a set of simple and practical design criteria for 13 mm headed studs.

Two recent developments, although not directly related to the behavior of steel-concrete composite connections, confirmed the versatility of the stub-girder floor system. The first is related to the dynamic response of the system. While the Nova building was under construction in Calgary, researchers from the University of Alberta instrumented two full bays of the sixth floor with accelerometers. Test results [15] revealed very low level of vibrations and the stub-girder system received very high recommendations from the investigators. The second development involves the first successful use of stub-girders as part of a rigid frame system. This feat was recently accomplished in a four story building in Mexico City [20].

#### 4. CONCLUDING REMARKS

In summary, two critical areas can be readily identified. Firstly, the stub-girder is susceptible to failure due to crushing of the concrete slab over the interior end of the end stub (location 1 in Fig. 5). Use of a wide centre concrete flute over the stubs together with transverse reinforcement placed at a lower level would likely remedy the problem. There is a lack of consensus among researchers on this issue [13, 19]. There is a definite need for further investigation in this general area.

The second critical area concerns the fillet welds along the interior end of the end stubs (location 2 in Fig. 5). These welds are prone to fracture due to excessive prying forces. In all of the full scale tests carried out at the University of Saskatchewan, loads were not placed on the concrete slab but were applied through the floor beams. This was done to simulate the loading condition likely to exist in an actual building. Some researchers [6] are of the opinion that observed prying forces could have been due to the loading system used. However, weld failure at this critical location was reported in full scale test [12] where loading was in fact placed on the concrete slab. The presence of prying forces was first observed in small size stub-girder tests where loads were also applied on the concrete slab [14].

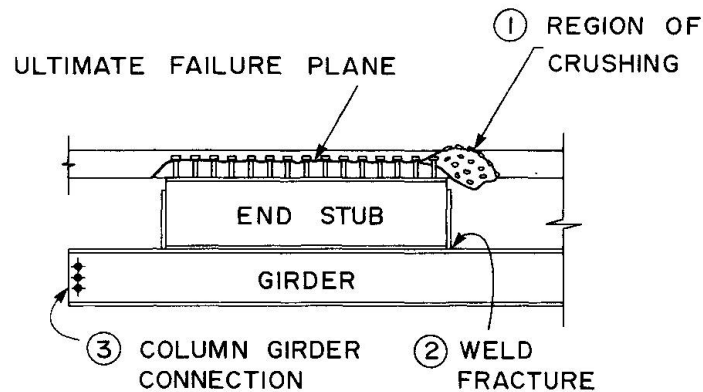

Fig. 5 Critical Areas

Mills [16] reported a third critical area, i.e. the connection between the column and the stub-girder (location 3 in Fig. 5). Slotted holes, loosely fastened bolts etc. have been used to eliminate unwanted bending in the columns. The concrete slab may require additional crack control reinforcing bars [4]. However, a rational way to solve this problem and at the same time achieve an overall construction saving is to modify the end details completely. The junior author is presently working on this project with technical assistance from the Canadian Institute of Steel Construction. Results of forthcoming full scale tests and analytical study are expected to answer some important questions and hopefully lead to the development of some specific design criteria.

#### ACKNOWLEDGEMENTS

The authors would like to thank the Canadian Institute of Steel Construction and the Bethlehem Steel Company for the information which they provided. The assistance of Heather Larson, who typed the manuscript, is gratefully acknowledged.

#### REFERENCES

1. BJORHOVDE, R. and ZIMMERMAN, T.J., Some Aspects of Stub-Girder Design, *Engineering Journal*, AISC Vol. 17, 1980, No. 3, pp. 54-69.
2. BUCKNER, C.D., DEVILLE, D.J., MCKEE D.C., Shear Strength of Slabs in Stub-Girders, *Journal of Structural Division*, ASCE, Vol. 107, No. ST2, Feb. 1981, pp. 273-280.
3. CHAN, T.W.K., REZANSOFF, T. and HOSAIN, M.U., Behaviour of Headed Shear Studs in Stub-Girder Stub Assemblages, *Proceedings of the 1984 CSCE Annual Conference*, Halifax, Nova Scotia, May 20-25, 1984, pp. 309-326.
4. CHIEN, E.Y.L. and RITCHIE, J.K., *Design and Construction of Composite Floor Systems*, Published by the Canadian Institute of Steel Construction, Toronto, Canada, September, 1984.
5. COLACO, J.P., A Stub-Girder System for High-Rise Buildings, *AISC Engineering Journal*, July, 1972, pp. 89-95.





6. CREED, M.W., Analysis and Testing of Stub-girders in a Building Structure, M.Sc. Thesis, Dept. of Civil Engineering, North Carolina State University, Raleigh, 1984.
7. GOSSELIN, G.C., and HOSAIN, M.U., Failure of Stub-Girders due to Longitudinal Shear, IABSE Periodica P-74, May, 1984.
8. GOSSELIN GUY, REZANSOFF T. and HOSAIN, M.U., Shear Failure Characteristics of Stub-Girders, Structural Engineering Report No. 20, September, 1980, University of Saskatchewan, Saskatoon, Canada.
9. GUNNIN, BILL L., The First International Building in Dallas, Texas, Acier Stahl Steel No. 3, 1976.
10. HOSAIN, M.U. and KULLMAN, R.B., Stub-Girder: An Innovative Structural Floor System for Highrise Buildings, Proceedings of the 3rd International Conference on Tall Buildings, Hon Kong and Guangzhou, December 10-15, 1984.
11. HOSAIN, M.U., and TSE, C., Failure Mechanisms of Stub-Girders, Proceedings of the 5th ASCE EMD Specialty Conference, Laramie, Wyoming, August 1-3, 1984.
12. INRYCO, INC., Report of Composite Girder Test, Project No. 1063, December 15, 1971.
13. KULLMAN, R.B. and HOSAIN, M.U., Shear Capacity of Stub-Girders: Full Scale Tests, ASCE Journal of Structural Engineering, Vol. III, No. 1, January 1985, pp. 56-75.
14. LAM, Y.W., REZANSOFF, T. and HOSAIN, M.U., An Experimental Investigation of Stub-Girders. Proceedings of the International Symposium on Behaviour of Building Systems and Building Components, Vanderbilt University, Nashville, Tennessee, March 8-9, 1979, pp. 365-384.
15. MATTHEWS, C.M., MONTGOMERY, C.J. and MURRAY, D.W., Designing Floor Systems for Dynamic Response, Structural Engineering Report No. 106, Dept. of Civil Engineering, University of Alberta, Edmonton, Canada, Oct. 1982.
16. MILLS, R.W., 401 West Georgia, Vancouver, B.C., Proceedings, Canadian Structural Engineering Conference, February, 1984, CISC, 300-201 Consumers Road, Willowdale, Ontario, Canada, M2J 4G8.
17. NADASKAY, A.J. and BUCKNER, C.D., A Scale Model Test of Stub-Girder Systems, Louisiana State University, 1983.
18. Pittsburg Testing Laboratory Report No. PG-6742, Built-Up Composite Girder Test-Project 201192131, January 11, 1972.
19. RITCHIE, J.K. and CHIEN, E.Y.L., Current Canadian Structural Research - Some Practical Aspects, Presented at the 3rd International Colloquium, Structural Stability Research Council, Toronto, Canada, May 9-11, 1983.
20. ROMERO, E.M., Continuous Stub-Girder Structural System for Buildings: A Case Study, University of Mexico, February, 1983.
21. Steel Structures for Buildings - Limit States Design, Canadian Standards Association Standard No. CAN3-S16.1-M78, Rexdale, Ontario, Dec. 1978.
22. ZIMMERMAN, T.J.E. and BJORHOVDE, R., Analysis and Design of Stub-Girders, Structural Engineering Report No. 90, University of Alberta, Edmonton, Canada, March, 1981.