

Relevant dynamic effects in the design of thin-walled structures

Autor(en): **Souza, Marco Antonio**

Objektyp: **Article**

Zeitschrift: **IABSE reports = Rapports AIPC = IVBH Berichte**

Band (Jahr): **49 (1986)**

PDF erstellt am: **23.07.2024**

Persistenter Link: <https://doi.org/10.5169/seals-38291>

Nutzungsbedingungen

Die ETH-Bibliothek ist Anbieterin der digitalisierten Zeitschriften. Sie besitzt keine Urheberrechte an den Inhalten der Zeitschriften. Die Rechte liegen in der Regel bei den Herausgebern.

Die auf der Plattform e-periodica veröffentlichten Dokumente stehen für nicht-kommerzielle Zwecke in Lehre und Forschung sowie für die private Nutzung frei zur Verfügung. Einzelne Dateien oder Ausdrucke aus diesem Angebot können zusammen mit diesen Nutzungsbedingungen und den korrekten Herkunftsbezeichnungen weitergegeben werden.

Das Veröffentlichen von Bildern in Print- und Online-Publikationen ist nur mit vorheriger Genehmigung der Rechteinhaber erlaubt. Die systematische Speicherung von Teilen des elektronischen Angebots auf anderen Servern bedarf ebenfalls des schriftlichen Einverständnisses der Rechteinhaber.

Haftungsausschluss

Alle Angaben erfolgen ohne Gewähr für Vollständigkeit oder Richtigkeit. Es wird keine Haftung übernommen für Schäden durch die Verwendung von Informationen aus diesem Online-Angebot oder durch das Fehlen von Informationen. Dies gilt auch für Inhalte Dritter, die über dieses Angebot zugänglich sind.

Relevant Dynamic Effects in the Design of Thin-Walled Structures

Effets dynamiques à considérer lors du dimensionnement
des structures à parois minces

Massgebende dynamische Effekte bei der Bemessung von
dünnwandigen Bauteilen

Marco Antonio SOUZA

Dr. Engineer
PUC/RJ – Dep. Eng. Civil
Rio de Janeiro, Brasil

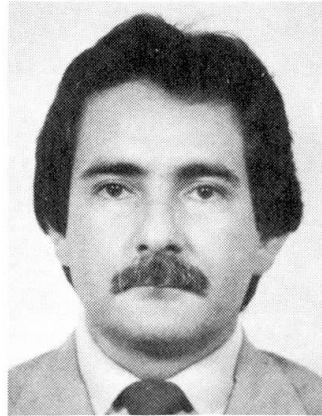

Marco Antonio Souza, born 1951, received his Ph.D. degree at University College London, England, in 1982. Since then he has been involved with different aspects relevant to the vibration analysis of structural elements liable to buckling.

SUMMARY

The present paper discusses relevant aspects to be considered in the design of thin-walled structural elements liable to buckling. The effects presented are of even greater importance if time dependent loads are to be considered.

RÉSUMÉ

Cette contribution met en évidence certains phénomènes qui doivent être pris en considération lors du dimensionnement d'éléments de structures à parois minces sensibles au flambement et au voilement. Ces effets sont d'autant plus importants si les charges à prendre en compte sont variables au cours du temps.

ZUSAMMENFASSUNG

In diesem Beitrag werden einige für die Bemessung von beulgefährdeten dünnwandigen Bauteilen massgebende Grundgedanken vorgestellt. Die Schlussfolgerungen erweisen sich als besonders wichtig, wenn auch zeitabhängige Beanspruchungen zu berücksichtigen sind.



1. INTRODUCTION

Resonance is one of the main concerns in the design of any structure which should respond safely to time dependent loads. The accurate calculation of the natural frequencies of the structure is therefore of major importance.

What the present paper discusses is relevant to the accurate calculation of the natural frequency of perfect and initially imperfect structural elements liable to buckling.

Since the purpose of this paper is to focus attention to aspects not often mentioned, the discussion will be based on results obtained by the author. A list of references containing the theoretical analysis will be presented at the end of the paper.

2. STABILITY AND VIBRATION CHARACTERISTICS

2.1 Stability Characteristics

The stability characteristics of perfect and also imperfect columns, plates and cylindrical shells are relatively well known. A summary of such characteristics is presented in figure 1 in terms of the equilibrium paths, diagrams of axial, or in-plane load in the case of plates, versus the transverse displacement.

As it can be seen from the diagrams shown in figure 1, the effects of the

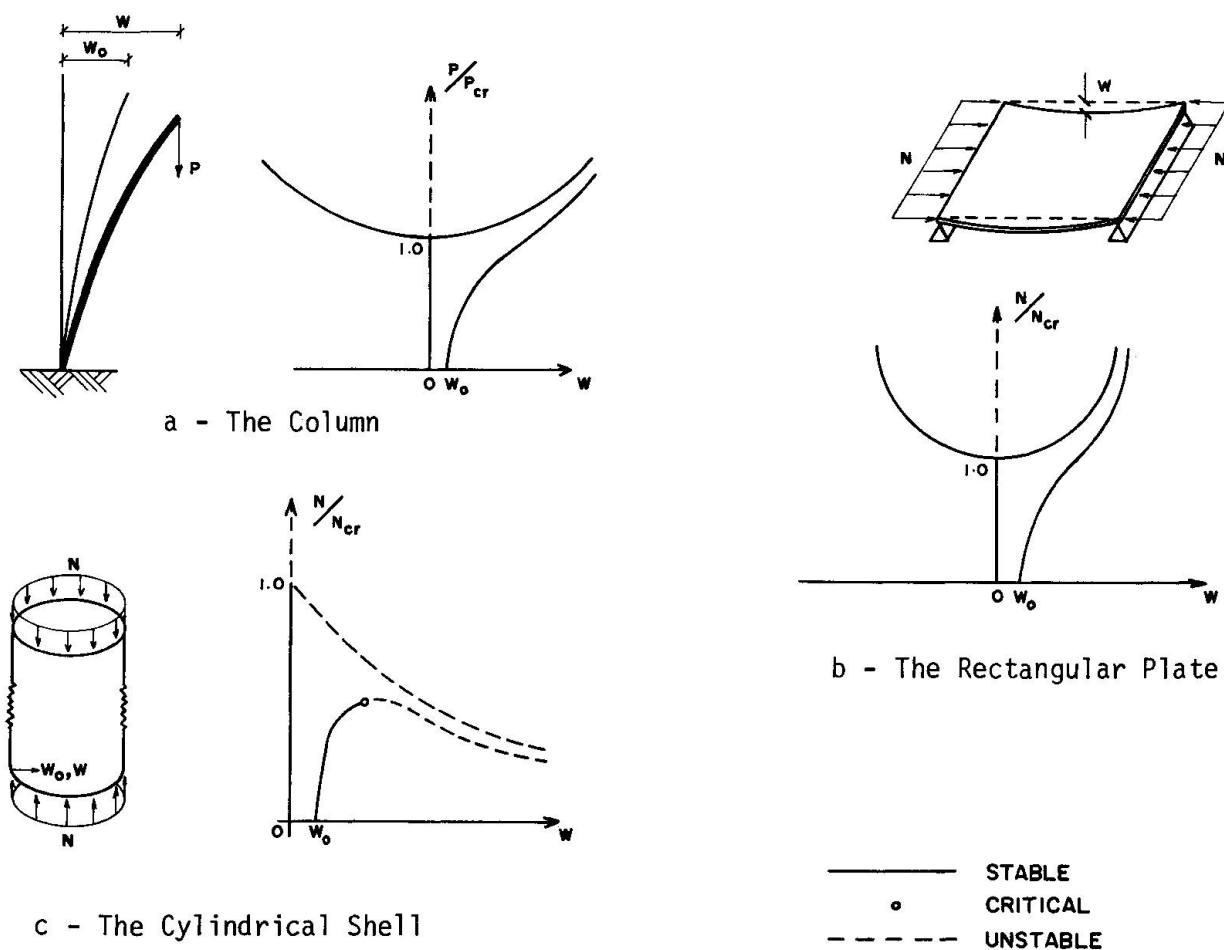

Fig. 1 Typical Equilibrium Paths

initial imperfection, represented by w_0 , on the stability characteristics of columns, rectangular plates and cylindrical shells are evident. In order to investigate the effects of the initial imperfection on the vibration characteristics of columns, plates and cylindrical shells the author used [1] a simplified model which reproduce similar stability characteristics to those of figure 1. The model and the stability characteristics are presented in figures 2 and 3, respectively.

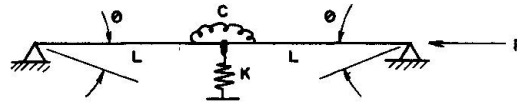

Fig. 2 The Model

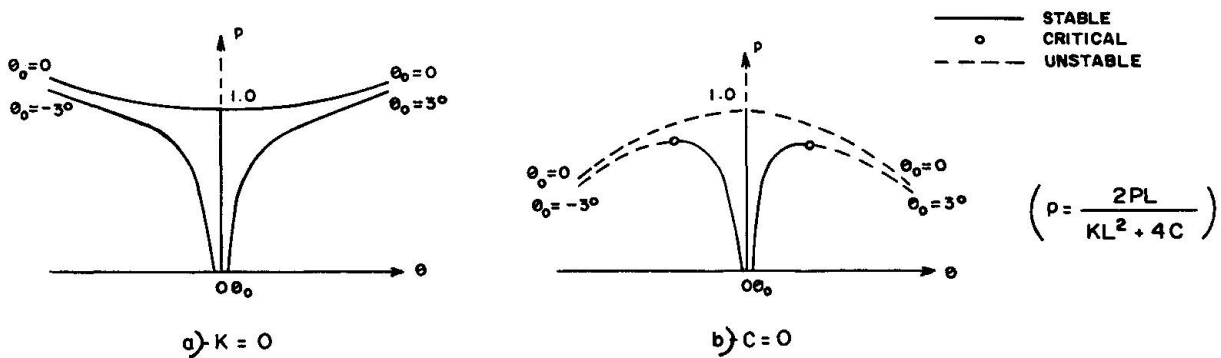

Fig. 3 Equilibrium Paths

The main advantage of the simplified model is the possibility it gives of considering different factors, such as the initial imperfection, without making the analysis too complex. This procedure was used and the vibration characteristics were determined.

2.2 Vibration Characteristics

The vibration characteristics of columns, plates and cylindrical shells can be obtained in terms of the relationship between the applied axial load and the square of the natural frequency. Such a relationship is obtained by investigating the vibration of the model around the equilibrium configurations [1].

Diagram of the square of the frequency versus the applied axial load for the model of figure 2 are presented in figure 4.

Therefore the relationship between the level of the axial load, the equilibrium configuration and the natural frequency is well determined. Figures 4-a,b corresponds to the equilibrium paths of fig. 3-a,b respectively.

Figure 4 illustrates how the initial imperfection affects the natural frequencies of vibration, for a certain load level: it raises the level of the natural frequency for columns and plates and lowers the level of the natural frequency in the case of cylindrical shells. The comparison being between the imperfect and the perfect structural element.

Major contributions to the subject were given by Massonnet [2,3]. His works are of great significance for anybody involved in the investigation of vibration char-

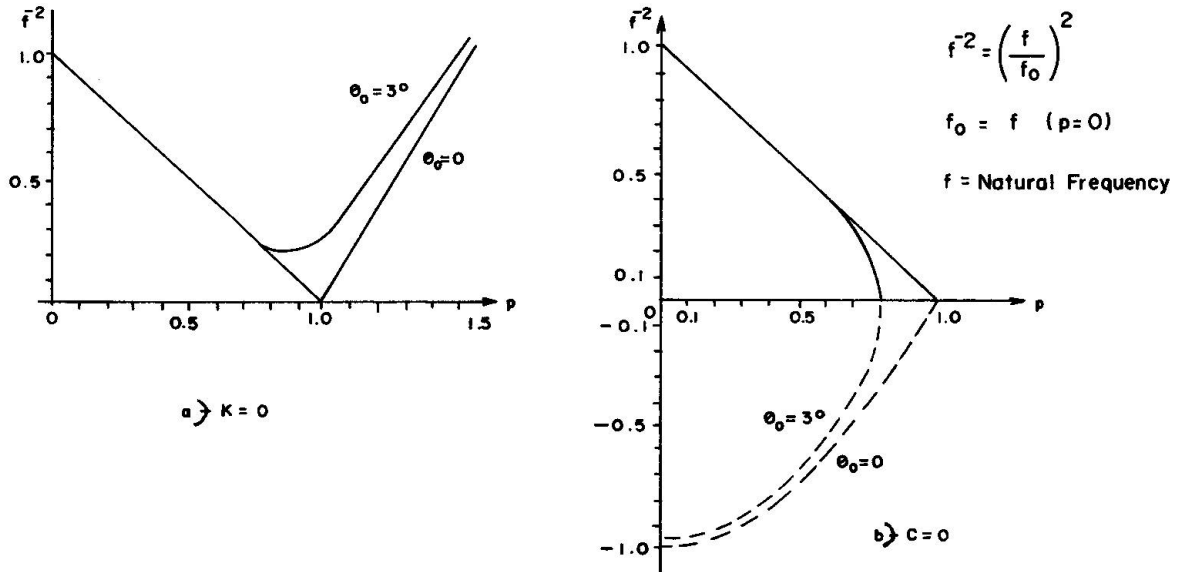

Fig. 4 (Frequency)² vs. Axial Load for the Model of fig. 2

acteristics of structural elements liable to buckling. Curves similar to those of figure 4 can be found in references [2,3].

Experimental results confirm the theoretical predictions obtained with such a simplified model as that of figure 2 [4,5,6].

3. DISCUSSION

The consequences of the effects showed previously on the design of structural elements liable to buckling will now be discussed. Two structural elements will be used in order to highlight the main aspects: a rectangular plate and a cylindrical shell model. The difference in the calculations of the level of frequency corresponding to resonance will be carried out stressing the importance of the consideration of the initial imperfections in the analysis.

3.1 The Rectangular Plate

The stability and the vibration characteristics of a square plate clamped along the edges were theoretically obtained by the author [7]. The results of the analysis are presented in figure 5 in terms of the in-plane loads versus the transverse deflection of the centre section and the curves of the square of the frequency versus the in-plane loading. The initial imperfection is taken into account in the analysis.

In order to illustrate how the level of the natural frequency is affected if the initial imperfection is considered or not let us consider the following values for the load ratio P/P_{cr} : 0.50; 0.70 and 2.00. The results of the calculations are presented in Table 1, where ϵ represents the difference between the value corresponding to the imperfect and the perfect cases.

As it can be seen from Table 1 the difference between the actual level of the natural frequency (if initial imperfection is present) and that corresponding to the perfect plate can be quite significant, even for levels of in-plane load much lower than the critical.

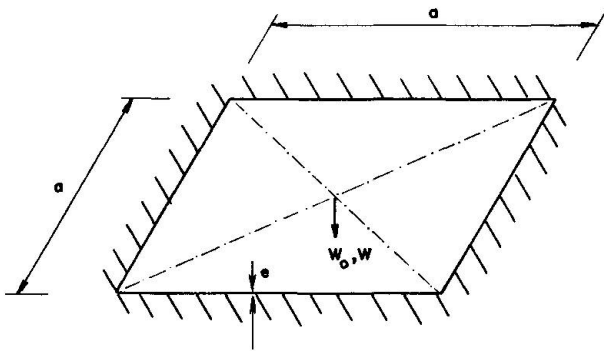

e = thickness

a = length of the sides

w_0 = deflection of the centre section

w = total deflection of the centre section

P = in plane loading

P_{cr} = critical load

f = natural frequency

f_0 = natural frequency corresponding to $P = 0$

$p = P/P_{cr}$

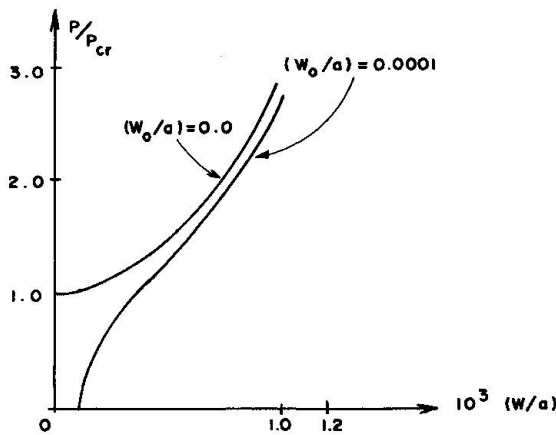

a - Equilibrium Path

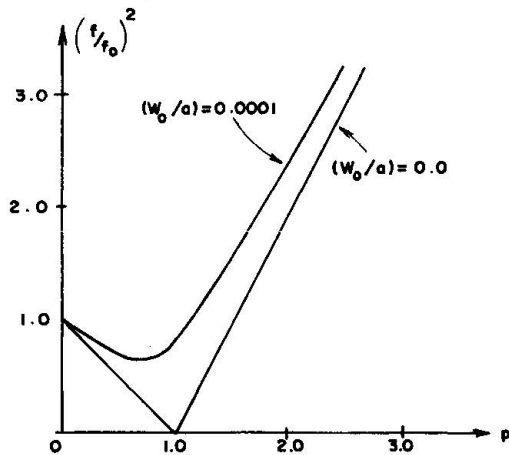

b - (Frequency)² vs. In Plane Load

Fig. 5 The Rectangular Plate [7], ($e/a=0.0025$)

The implications on design are evident: suppose the plate was considered to be perfectly flat in the analysis and the actual plate exhibited an initial imperfection even before the in-plane loading started. As a consequence, for instance, for $P = 0.70 P_{cr}$ the square of the frequency will be 113% higher than the calculated value since the plate was assumed to be perfect. Resonance therefore will not occur in the expected level of the natural frequency. This example illustrates the importance of the consideration in the analysis of realistic initial imperfection profiles.



P	$(f/f_0)^2$		$\epsilon\%$
	$w_0/a=0.0$	$w_0/a=10^{-4}$	
0.50	0.50	0.68	36.0
0.70	0.30	0.64	113.0
1.00	2.00	2.43	21.5

Table 1 Effects of the Initial Imperfection - Rectangular Plate

3.2 The Cylindrical Shell

In order to illustrate how the initial imperfection affects the vibration characteristics of cylindrical shells a simplified model was introduced by the author [8]. The model and its stability and vibration characteristics are reproduced in figure 6.

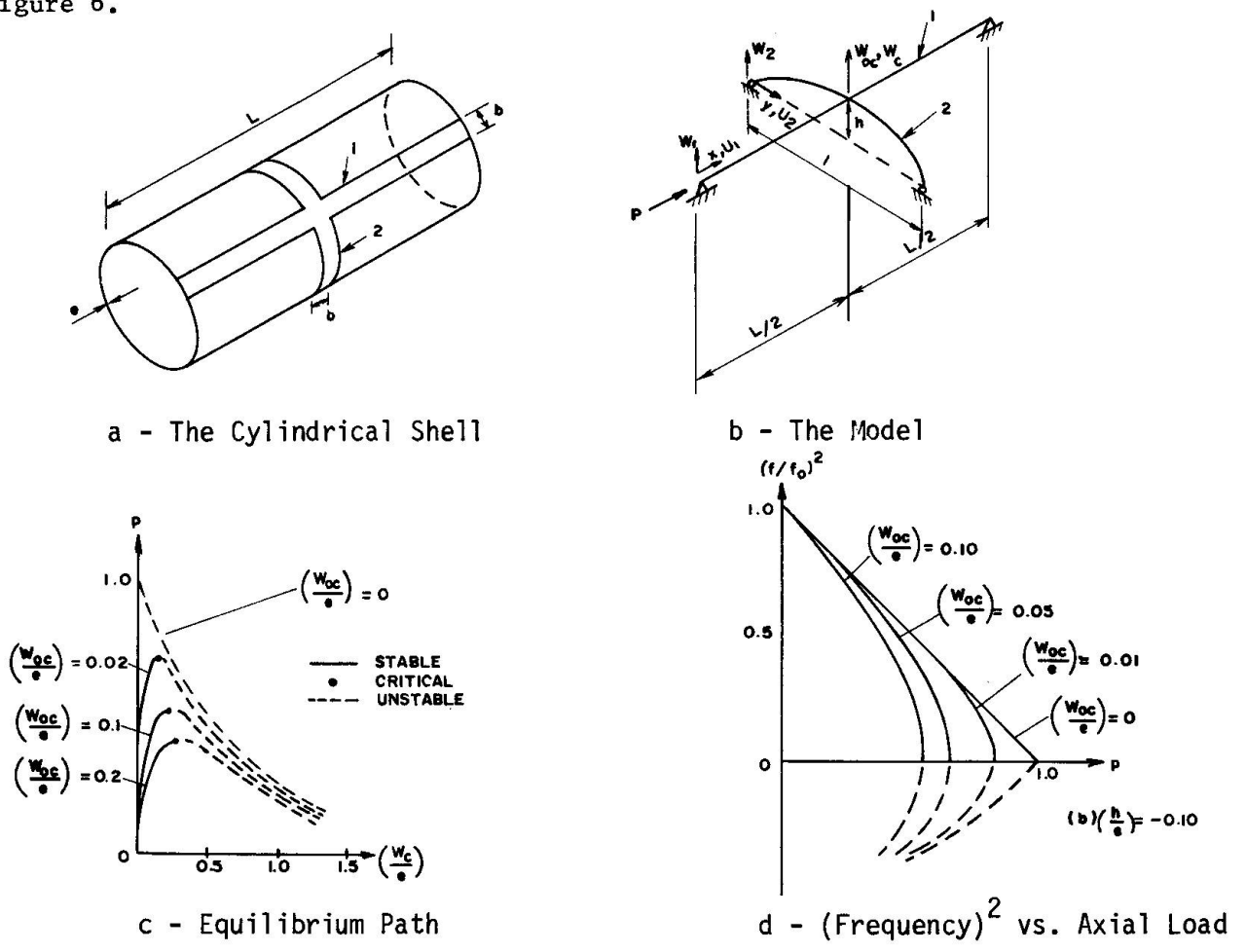

Fig. 6 The Cylindrical Shell Model

As it can be seen from figure 6 the equilibrium paths are similar to those corresponding to the actual shells. In the case of cylindrical shells the consequences are even more dramatic since the initial imperfection lowers the load carrying capacity of the shell. In the frequency range resonance can occur for a much lower level of axial load than expected if the initial imperfection is not included in the calculations.

As an example let us consider $P = 0.60 P_{cr}$ in figure 6-c. Table 2 contains the



values of interest for the discussion. ϵ represents the difference between the imperfect and the perfect values.

p	$(f/f_o)^2$			
	$w_o/e = 0.0$	$w_o/e = 0.01$	$w_o/e = 0.05$	$w_o/e = 0.10$
0.60	0.40	0.38	0.22	-
$\epsilon\%$	0.0	-5.0	-45.0	-

Table 2 Effects of the initial imperfection - Cylindrical Shell

Therefore resonance can occur for levels of frequency much lower than expected: 45.0% (for $w_o/e = 0.05$) of difference in the square of the frequency corresponding to 67.08% in the frequency level. The shell can be destroyed much earlier than feared.

This is another example used in order to stress the necessity of accurately calculating the natural frequency.

4. CONCLUSIONS

Relevant aspects to be taken into account in the design of thin-walled structures liable to buckling were presented. The need of incorporating realistic initial imperfection profiles in the calculation of the natural frequency was stressed. Examples were presented highlighting the fact that resonance can occur for different levels of the natural frequency if the structural element to be designed is assumed to be perfect.

Other effects such as residual stresses, temperature, changes of support conditions during the loading process, material non-linearity on the stability and vibration characteristics of structural elements liable to buckling must also be accounted for. Such effects have also been investigated by the author and hopefully the results will give extra information to be considered in the design of thin-walled structural elements liable to buckling subjected to time dependent loading.

REFERENCES

1. SOUZA M.A., Post-Buckling Vibration Characteristics of Structural Elements. 1984. SSRC Annual Technical Session, pp. 183-190.
2. MASSONNET C., Les Relations entre les Modes Normaux de Vibration et la Stabilité des Systèmes Elastiques. Bulletin des Cours et des Laboratoires d'Essais des Constructions du Génie Civil et d'Hydraulique Fluviale, Tome I, Nos. 1 and 2, 1940, Brussels, Belgium.
3. MASSONNET C., Le Voilement des Plaques Planes Sollicitées dans Leur Plan. Final Report of the International Association for Bridge and Structural Engineering, Liège, Belgium, 13-18 September, 1948, pp. 291-300.
4. JUBB J.E.M.; PHILLIPS I.G. and BECKER H., Interrelation of Structural Stability, Stiffness, Residual Stresses and Natural Frequency. Journal of Sound and Vibration, 1975, Vol. 39(1), pp. 121-134.
5. LURIE H., Lateral Vibrations as Related to Structural Stability. Journal of Applied Mechanics, June 1952, pp. 195-204.
6. SINGER J., Buckling Experiments on Shells - A Review of Recent Developments.



Euromech Colloquium No. 128: Stability, Buckling and Postbuckling Behavior; Foundations and Analysis, Delft, Holland, March 31 - April 2, 1980.

7. SOUZA M.A., Vibration Characteristics of Buckled Structures. Ph.D. Thesis, University of London, 1982.
8. SOUZA M.A. and WALKER A.C., Vibration Characteristics of Buckled Cylinders. International Symposium on Offshore Engineering - Brasil Offshore'81, Rio de Janeiro, Brasil, 14-19 September, 1981, Pentech Press, 1982, pp. 382-394.