

**Zeitschrift:** IABSE reports = Rapports AIPC = IVBH Berichte  
**Band:** 49 (1986)

**Artikel:** Spacing of connections in thin-walled compression elements  
**Autor:** Yener, Muzaffer  
**DOI:** <https://doi.org/10.5169/seals-38292>

### **Nutzungsbedingungen**

Die ETH-Bibliothek ist die Anbieterin der digitalisierten Zeitschriften. Sie besitzt keine Urheberrechte an den Zeitschriften und ist nicht verantwortlich für deren Inhalte. Die Rechte liegen in der Regel bei den Herausgebern beziehungsweise den externen Rechteinhabern. [Siehe Rechtliche Hinweise.](#)

### **Conditions d'utilisation**

L'ETH Library est le fournisseur des revues numérisées. Elle ne détient aucun droit d'auteur sur les revues et n'est pas responsable de leur contenu. En règle générale, les droits sont détenus par les éditeurs ou les détenteurs de droits externes. [Voir Informations légales.](#)

### **Terms of use**

The ETH Library is the provider of the digitised journals. It does not own any copyrights to the journals and is not responsible for their content. The rights usually lie with the publishers or the external rights holders. [See Legal notice.](#)

**Download PDF:** 07.10.2024

**ETH-Bibliothek Zürich, E-Periodica, <https://www.e-periodica.ch>**

## Spacing of Connections in Thin-Walled Compression Elements

Ecartement des points d'assemblage dans les éléments  
à parois minces comprimés

Abstände von Verbindungsmitteln bei dünnwandigen Druckelementen

### Muzaffer YENER

Assist. Professor  
Purdue University  
West Lafayette, IN, USA



Muzaffer Yener, born 1947, received his B.S. degree in civil engineering and M.S. degree in structural engineering from New York University in New York, NY. He worked a total of five years as a design engineer and a supervisor. He received his Ph.D. degree from Cornell University, Ithaca, NY.

### SUMMARY

A great variety of cold-formed steel shapes are often used in combination with cover plates to form closed cellular panels. In this paper, the spacing requirements of connectors that are used to fasten the cover plate to the fluted sheet are investigated. First, an experimental investigation for the design of cellular cold-formed steel panels with intermittent connections is described. Based on elastic plate buckling theory and experimental observations, an analytical development of criteria for maximum connection spacing is presented.

### RÉSUMÉ

Une grande variété de profils ouverts formés à froid est utilisée en combinaison avec une tôle plane de façon à constituer une plaque à cellules fermées. Cette contribution concerne l'étude de l'écartement nécessaire des points d'assemblage fixant la tôle plane à la tôle profilée. En premier lieu, on décrit une recherche expérimentale sur le dimensionnement des plaques cellulaires en acier formé à froid à points d'assemblages discontinus. Puis on présente le développement analytique des critères d'espacement maximal des assemblages basé sur la théorie du voilement élastique des plaques et sur les observations effectuées lors des essais.

### ZUSAMMENFASSUNG

Eine grosse Vielfalt von kaltgeformten Profilen wird oft in Verbindung mit Deckplatten verwendet, um geschlossene kastenförmige Elemente zu bilden. Dieser Artikel beschreibt die Anforderungen an die Abstandswahl von Verbindungsmitteln, welche zur Befestigung der Deckplatte an das Wellblech verwendet werden. Zuerst wird eine Untersuchung über die Bemessung dieser Elemente mit nicht kontinuierlichen Verbindungen beschrieben. Basierend auf der elastischen Beultheorie für Platten und auf experimentellen Untersuchungen wird eine analytische Herleitung des Kriteriums für die beste Abstandswahl der Verbindungen vorgestellt.



## 1. INTRODUCTION

A great variety of cold-formed steel shapes is often used in combination with cover plates, as shown in Fig. 1, to form closed cellular panels. In this paper, experimental and analytical investigations of the spacing requirements of connectors that are used to fasten the cover plate to the fluted sheet to resist gravity loads are summarized. Comparisons with test results are also made.

It is of economical importance to design such composite sections so that the cover plate can be considered as an integrated, load-carrying component of the assembly. In composite thin-walled members, the maximum allowable spacing of connections in compression elements is governed either by the allowable strength of the connection, or by separation of the component compression plates along the lines of connections.

An experimental investigation was conducted on single-span, two-span, and multi-span panels with the geometry shown in Fig. 2. Panel strength and stiffness under gravity loading were measured on cellular panels made from a fluted sheet and a cover plate connected with four lines of rivets. Some of the test panels had either the cover plate or the flats of the fluted sheet perforated, with or without a wire mesh placed between them, in order to improve acoustic properties. The test program and results are described in Ref. 4. The behaviors of identically designed riveted and welded panels are compared. Shear strength and the slip load value of the rivets were determined with single-shear strap tests for several combinations of sheet thickness. Based on the information obtained from 190 strap tests, 25 full-scale flexural tests (17 single-span, 4 two-span, and 4 three-span) were conducted to determine panel strength and deflection behavior.

Based on experimental observations, the elastic plate buckling theory is used to develop criteria for maximum connection spacing in cold-formed steel cellular panels. The spacing criterion developed here for preventing the separation of the cover plate from the fluted sheet of the panel ensures the continuous stiffening effect along each line of connections. The requirement regarding unstiffened flanges is determined by assuming a slight amount of rotational restraint along their supported edges.

## 2. EXPERIMENTAL OBJECTIVES

The primary function of fasteners in cold-formed steel roof decks and floor panels is to resist shear stresses produced by flexural loading. Allowable shear force for spot welded connections, and allowable shear and bearing stresses for bolted connections are given in the AISI Specification [1]. For riveted connections, it is suggested that shear strength of rivets be experimentally determined on representative specimens. Thus, one of the main objectives of this investigation was to determine the strength of the rivet connectors in 24-in. wide panels, using single lap joint shear tests.

In the present AISI Specification the maximum intermittent connection spacing is based on the assumption of preventing the cylindrical buckling of the compressed element between adjacent connectors, as shown in Fig. 1. In addition to preventing cylindrical buckling, consideration is also given to the local buckling of the unstiffened edge compression flanges of the fluted sheet. On the basis of the speculation that the AISI provisions may be overly conservative for cellular

panels, the following question was raised: How would the strength of the assembly be affected if the spacing were made so large as to allow slight separation of the connected compression elements? That is, would local plate buckling really terminate the useful life of the cover plates? This concern was the primary impetus in undertaking this investigation.

Separation of the compressed elements, if allowed, would tend to cause reduction in panel flexural stiffness, in addition to that produced by connection slip. At present, there is no available method for predicting deflections in a connected light-gage assembly, taking into account the slippage and separation. Therefore additional questions of importance to be considered in the investigation were: (1) How would rivet slippage and slight separation of cover plates affect the stiffness of the assembly? (2) Taking the effects of both separation and slippage into account, could the deflection be predicted with sufficient accuracy?

Two additional issues related to strength were also studied: (1) What is the maximum value of connection spacing which can be tolerated in cases where deflection is of secondary importance? and (2) How would the behavior of identical panels with riveted and welded connections differ?

### 3. PRELIMINARY DESIGN CONSIDERATIONS AND TEST RESULTS

After the characteristics and strength of the connections were determined from strap tests [3,4], attention was focused on the design of simple and multiple span beams. For the flexural strength determinations, a panel was considered to consist of three identical box beams situated side by side [3].

The testing of uniformly loaded single span panels with cover plates down was proposed to verify panel strength and stiffness with connected elements in tension where only connector strengths should be of concern. In order to observe the effects the plate separation along the lines of rivets had on the strength and stiffness of the assembly, single-span beams with cover plates up (connected plates in compression) were also proposed for testing. Furthermore, to simulate actual field application more precisely, the testing of full-scale continuous beams was thought to be essential. Uniform load is plotted against the average of the maximum span deflections in Fig. 3 for the two-span continuous panel specimens. The detailed test results are given in Ref. 3.

### 4. PROPOSED THEORETICAL SPACING CRITERIA

On the basis of experimental observations, spacing intermittent connections in cellular panels in accordance with the AISI Specifications appears to be overly conservative. The proposed alternative provision for the prevention of the separation of a compressed cover plate from the fluted sheet is based on the buckling configuration shown in Fig. 4, as observed in experiments. If the connection spacing is such that the cover plate can be suppressed into this configuration, a continuous stiffening effect along the lines of connections is achieved until the maximum edge stress  $\sigma_c$  reaches the yield stress  $\sigma_y$ . There are three possible ways in which the development of the assembled member strength predicted on the basis of monolithic action may be hindered. The maximum allowable connection spacing  $s$  is the smallest value obtained by simultaneously considering the three criteria described in the following.



#### 4.1 Allowable Strength of Connection

This is a rather straightforward stipulation which simply states that the spacing  $s$  is not to exceed that which is required to transmit the force induced by applied loads at connections, on the basis of allowable connection strength.

#### 4.2 Separation of Compressed Cover Plate

In Ref. 2, the buckling configuration in Fig. 4 is used to develop a spacing requirement to prevent the separation of the cover plate. Considering each cell separately, a general expression for one half-wave length  $\lambda = a/m$  (Fig. 4), in terms of the compressive stress  $\sigma_c$  is found:

$$\sigma_c = \frac{0.904E}{(w_c/t)^2} \left( \frac{1}{c} + c \right)^2 \quad (1)$$

where  $c = a/mw$ . Solving this quadratic equation for  $c$ , and assuming that, if the buckling configuration shown in Fig. 4 is to occur, at least one extra fastener should be placed within one half-wave length (i.e.,  $\lambda = 2s$ ) results in,

$$s = 0.5t \sqrt{\frac{E}{\sigma_c}} \left[ 1 + \left( \frac{0.95}{w_c/t} \sqrt{\frac{E}{\sigma_c}} \right)^2 \right] \quad (2)$$

Eq. 2 is further simplified by considering the effective section properties of real plates to give  $s = 0.6w = 0.6 w/n$ , in which  $n =$  number of typical cells in the panel of width  $w$ , and  $w_c = w/n$ .

#### 4.3 Separation of Unstiffened Compression Plate Elements

When the cover plate is in compression, both of the outstanding flanges of the fluted sheet would also be in compression. Such unstiffened compression elements tend to buckle at smaller stresses and into longer half-waves than corresponding stiffened plates. The buckling configuration of a compressed unstiffened plate is shown in Fig. 5.

Assuming that a small amount of rotational restraint is provided by the web element, the half buckling wave length is found in Ref. 2 to be  $\lambda = 17 w$ . Again, placing one extra connection within the length  $\lambda$  gives  $s = 8w_u$ . The lower bounds for  $s$  are also provided in Ref. 2.

### 5. CONCLUSIONS AND COMPARISON WITH TESTS

This paper contains a summary of the experimental behavior of composite cold-formed steel panels with riveted and welded connections. The validity of predicting panel strength, regardless of whether the cover plate is in compression or in tension, by assuming a fully composite action has been substantiated by the testing program. Tests have also indicated that panels were somewhat more flexible than predicted on the basis of fully composite action.

In addition, based on elastic plate buckling theory, design criteria for intermittent connection spacing in thin-walled steel cellular panels under flexural loading are developed. The proposed requirements are simple and suitable for direct use in practical design. The proposed requirements as well as the AISI provisions

are compared with the available test data in Ref. 2. Comparison of the spacing values for specimens in which the cover plate was in compression indicates that for these cellular test panels, the proposed criteria require only one fastener for every three required by the AISI provisions, corresponding to a savings of approximately 67%. The comparison has also revealed that, even though the proposed requirements result in larger values for maximum connection spacing, they appear to be considerably conservative when compared with the test results.

#### REFERENCES

1. Specifications for the Design of Cold-Formed Steel Structural Members, American Iron and Steel Institute, Washington, D.C., 1980.
2. YENER, M., "Criteria for Connection Spacing in Cold-Formed Steel," J. of Struct. Engrg., ASCE, Vol. 110, Sept., 1984, pp. 2178-2195.
3. YENER, M., and WHITE, R.N., "Cold-Formed Steel Panels with Riveted Connections," J. of Struct. Engrg., ASCE, Vol. 110, May, 1984, pp. 1035-1050.
4. YENER, M., and WHITE, R.N., "Progress Reports on Walcon Corporation 24-in. NDU Panels, R1 through R8," Dept. of Struct. Engrg., Hollister Hall, Cornell University, Ithaca, N.Y., 1978-1980.

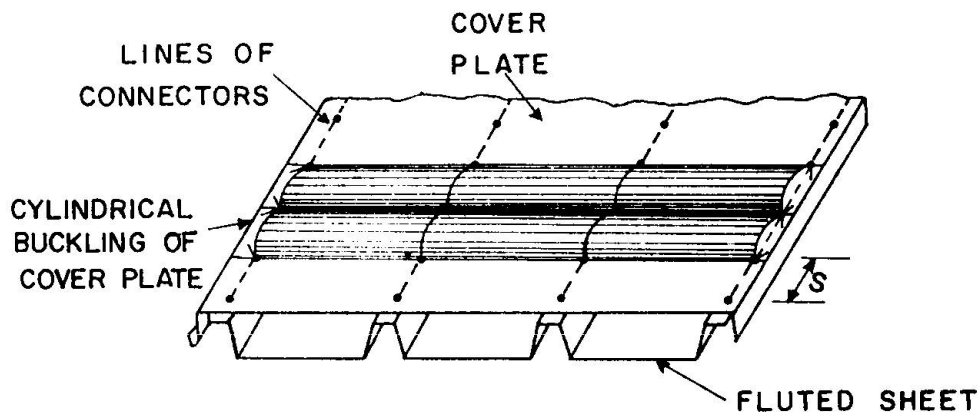

Fig. 1 - Cellular Panel with Flat Cover Plate

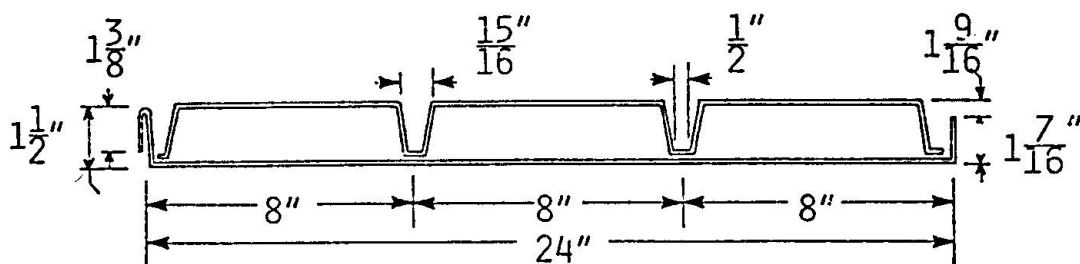

Fig. 2 - 24" Wide Panel Without Stiffeners

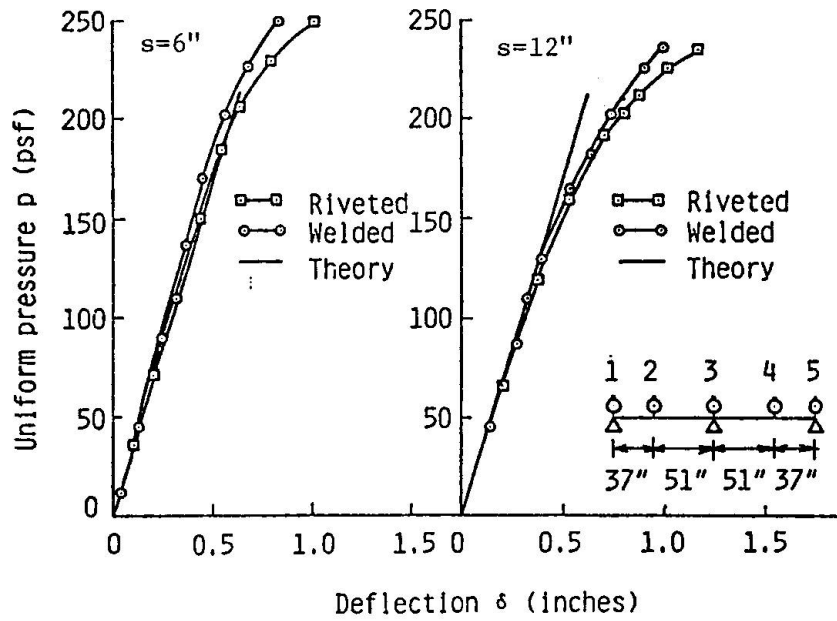

Fig. 3 - P- $\delta$  Curves for Two-Span Continuous Panels

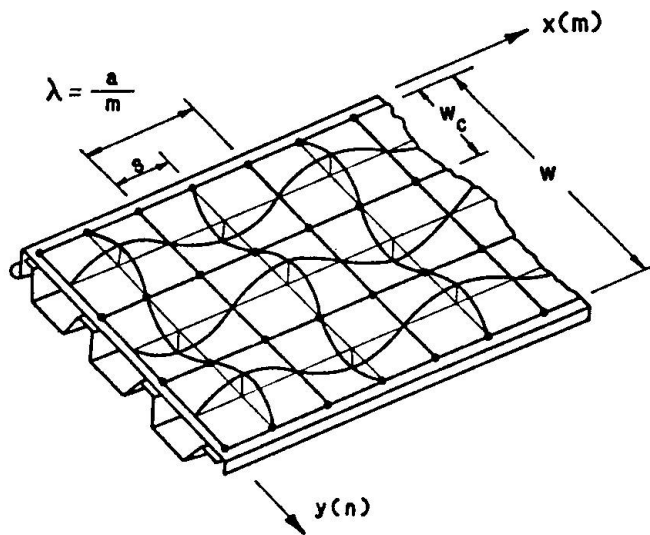

Fig. 4 - Buckling Configuration of Cover Plate With Adequate Connection Spacing

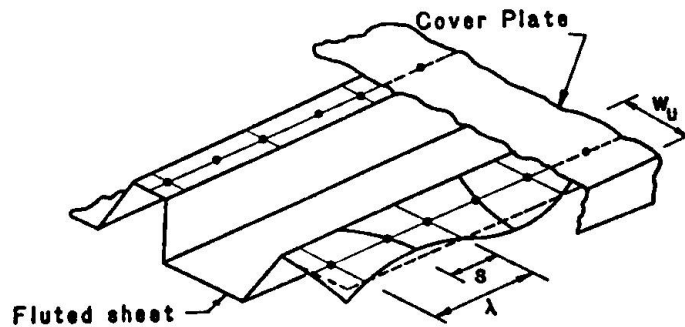

Fig. 5 - Buckling of Outstanding Unstiffened Flanges