

Torsional restraint coefficients of profiled sheeting

Autor(en): **Lindner, Joachim / Gregull, Thomas**

Objektyp: **Article**

Zeitschrift: **IABSE reports = Rapports AIPC = IVBH Berichte**

Band (Jahr): **49 (1986)**

PDF erstellt am: **23.07.2024**

Persistenter Link: <https://doi.org/10.5169/seals-38295>

Nutzungsbedingungen

Die ETH-Bibliothek ist Anbieterin der digitalisierten Zeitschriften. Sie besitzt keine Urheberrechte an den Inhalten der Zeitschriften. Die Rechte liegen in der Regel bei den Herausgebern.

Die auf der Plattform e-periodica veröffentlichten Dokumente stehen für nicht-kommerzielle Zwecke in Lehre und Forschung sowie für die private Nutzung frei zur Verfügung. Einzelne Dateien oder Ausdrucke aus diesem Angebot können zusammen mit diesen Nutzungsbedingungen und den korrekten Herkunftsbezeichnungen weitergegeben werden.

Das Veröffentlichen von Bildern in Print- und Online-Publikationen ist nur mit vorheriger Genehmigung der Rechteinhaber erlaubt. Die systematische Speicherung von Teilen des elektronischen Angebots auf anderen Servern bedarf ebenfalls des schriftlichen Einverständnisses der Rechteinhaber.

Haftungsausschluss

Alle Angaben erfolgen ohne Gewähr für Vollständigkeit oder Richtigkeit. Es wird keine Haftung übernommen für Schäden durch die Verwendung von Informationen aus diesem Online-Angebot oder durch das Fehlen von Informationen. Dies gilt auch für Inhalte Dritter, die über dieses Angebot zugänglich sind.

Torsional Restraint Coefficients of Profiled Sheeting

Coefficient d'encastrement à la torsion dû à la tôle profilée

Drehbettungswerte von Trapezprofilen

Joachim LINDNER

Prof. Dr.
Techn. Univ. Berlin
Berlin



Joachim Lindner, born in 1938, worked in the structural steel fabricating industry and later with an industrial scaffolding company. Since 1974, he has been Professor for steel structures at the Technical University, Berlin. His main research activities centre on the area of stability.

Thomas GREGULL

Dipl.-Ing.
Techn. Univ. Berlin
Berlin

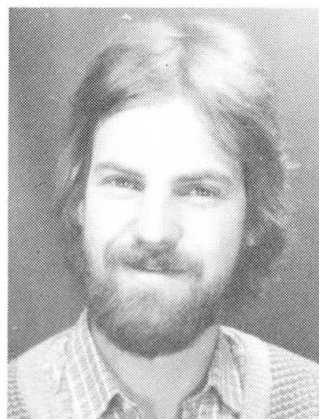

Thomas Gregull, born in 1958, completed his structural engineering studies in 1984 at the Technical University Berlin. Afterwards he joined the scientific staff of the University, structural-steel department, and is involved in research into the stability of struts, and the stabilising of purlins.

SUMMARY

In the dimensioning of steel-purlins it is customary to take into consideration the mitigating action of the roof-skin with respect to lateral torsional buckling. The rotationally flexible restraint is especially achieved by profiled sheeting. The value of the torsional spring under consideration is mainly limited by the flexible connection between purlin and roofing-skin. This report deals with research into the assessment of the torsional bearing assumed in calculations. Different connection-types, with and without thermal insulation between purlin and roofing-skin, are being investigated. An example illustrates application.

RÉSUMÉ

Lors du dimensionnement des pannes, la couverture, surtout celle constituée de tôles trapézoïdales, est très souvent considérée comme un appui latéral contre le déversement. La valeur de ce coefficient d'encastrement à la torsion est fonction de la souplesse de l'assemblage entre panne et couverture. Il est question ici de rechercher le coefficient adéquat à l'aide de plusieurs essais. Sont examinés différents types d'assemblage avec ou sans isolant thermique entre panne et couverture.

ZUSAMMENFASSUNG

Bei der Bemessung von Stahlpfetten wird die Dacheindeckung, insbesondere Trapezbleche, häufig als drehfedernde Stützung beim Nachweis gegen Biegedrillknicken angesetzt. Die Größe der anzusetzenden Drehfeder wird aber wesentlich durch die weiche Verbindung Pfette-Dachhaus bestimmt. Hier wird über Versuche zur Ermittlung der anzusetzenden Drehbettung berichtet. Es werden unterschiedliche Anschlusskonstruktionen mit und ohne Wärmedämmung zwischen Pfette und Dachhaut untersucht.



1. GENERAL

When dimensioning steel-purlins, it is customary to consider in increasing magnitude the supporting-action of the roofing components as restraint against lateral torsional buckling, the main reason for this being commercial considerations. Depending on the type of roofing-skin being used, the horizontal dislocation of the upper chord is being restrained by the shear stiffness R and/or the twisting of the purlin is being limited by the bending-resistance of the roofing-skin. In the calculations, the bending-resistance of the roofing is being accounted for by the value c_y of the torsional bearing. Relevant formulae to establish the ideal buckling-moment in consideration of the torsional bearing and the shear stiffness are given for instance in [1], [2], [3], [4].

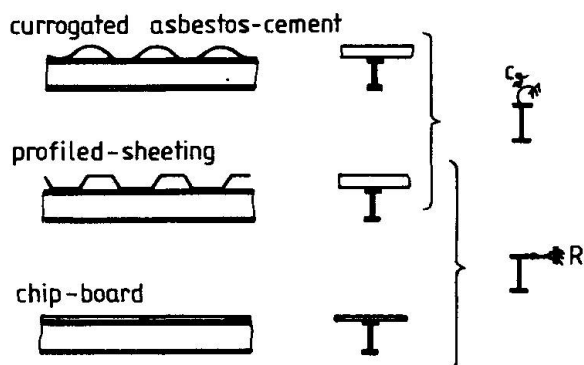

Fig. 1 Stabilizing by adjacent components

This article analyses the value of the applicable torsional restraint coefficient. Assuming an effective areal connection between roofing-skin and purlin, the torsional spring is easily established by way of the flexural stiffness of the roofing-skin. Due to the localised nature of the fastening (i.e. with bolts), additional deformation takes place local to the fixing-points, so that the flexural stiffness may only partly be utilized. The use of thermal insulation between purlin and roof-skin causes, by the compression thereof, further deformation.

The tests in [5], [6], in which measurements of the torsional restraint coefficient values were taken on different roof-skin configurations without live-loads, show the deformation local to the connection to have a significant influence on the distortion of the purlin and to be distinctly more prominent than the deflection of the roof-skin.

A research-project is under way at the Technical University Berlin, in which investigations of the torsional restraint coefficient values under applied live-loads are being carried out [7].

In this, the following parameters are being varied:

- construction of the roofing-skin,
- location and distance of the fixings (ridge, trough, fasteners in every or alternate ridge/trough)
- roofing-construction (with or without intervening thermal insulation, type of thermal insulation used),
- purlin-construction (hot-rolled section, cold formed section).

The following reports on the results of preliminary tests, which preceded the test-programme as laid down in [7].

2. DETAILS OF ROOF-STRUCTURE IN TEST

Representative for hot-rolled sections in the I range, IPE 160 purlins were used in the tests. As roof-sheeting, a profiled steel-sheet 40 x 183 x 0.75 mm in inverted position (see Fig. 2) was chosen. Part of the tests was carried out with a thermal insulation of extruded polystyrol rigid foam panels inserted between purlins and sheeting. The fixing of sheeting and purlins was by way of self-tapping screws ϕ 6.3 mm. The fixings in the bottom-chord incorporated ϕ 19 mm washers, in some instances ϕ 29 mm spreader washers were used instead. Fixings in the top-chord incorporated "Orkan-Calottes" of 0.75 mm thickness.

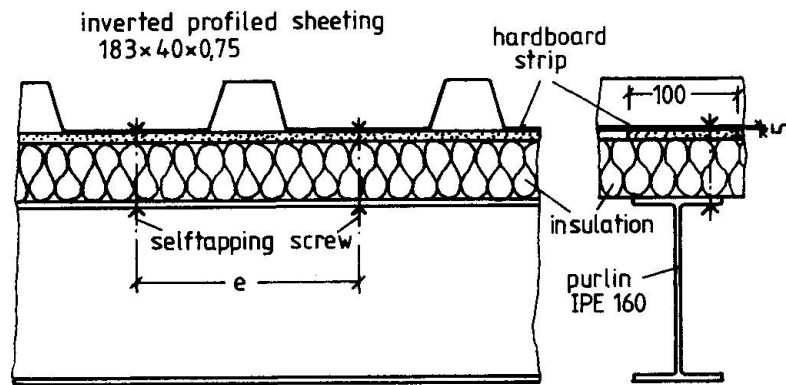

Fig. 2 Roof-construction with thermal insulation

3. TEST CONFIGURATION

The tests were conducted on realistically constructed roof-sections. For this purpose, two purlins were installed at a distance c/c of $a=3.0$ metres with the roofing-skin affixed. A torsional moment was introduced into the purlins and the resulting distortion \mathcal{J} being measured. Fig. 3 shows the principle of the test-configuration. The rotation of the purlin was being facilitated by the use of self-aligning ball-bearings and the horizontal dis-location in direction of the roofing-skin span by inserting ball-bearing-racks beneath the rotational bearings. By virtue of this configuration, bearing friction could be reduced to a negligible amount. The complete test-piece, including the bearings, was then installed in a test-rig which also provided the anchorage for the hydraulic cylinders, required to simulate the live-loading.

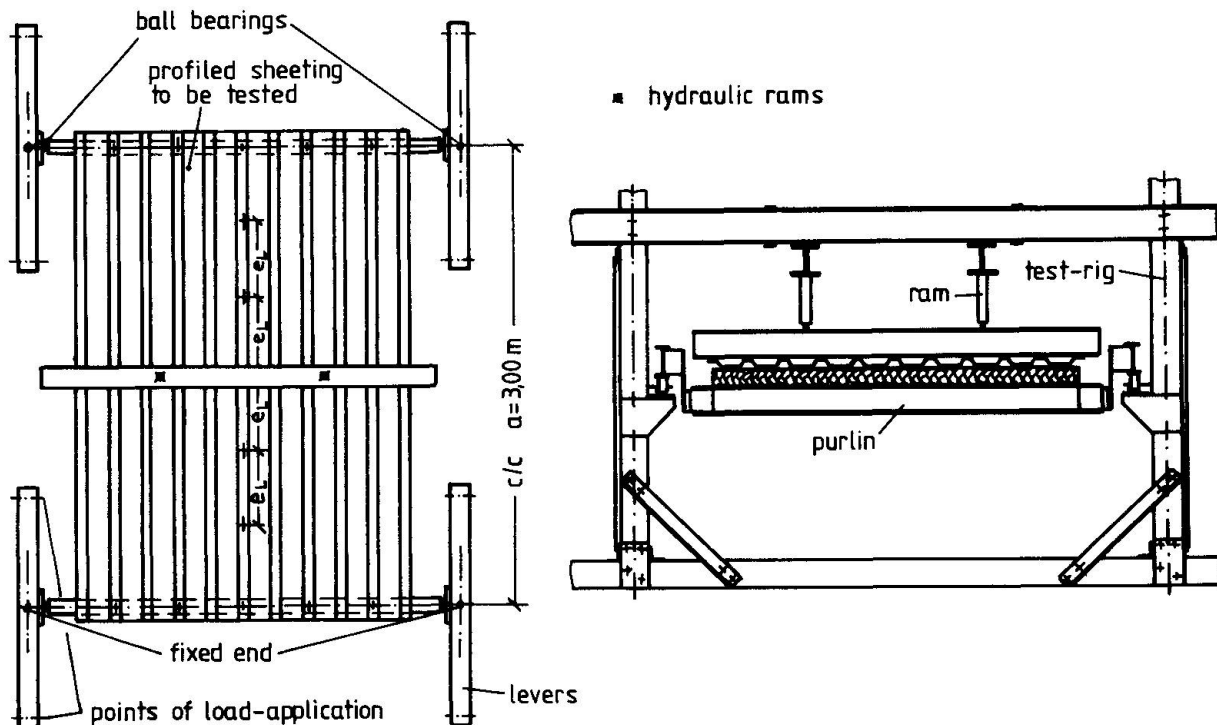

Fig. 3 Test Configuration



4. CONDUCTING OF TEST

4.1 Load application

The imposed load generated by 2 hydraulic cylinders was applied to the roof by way of a steel beam, as uniform distributed load acting at mid-span of the profiled sheeting. The resultant reaction of the profiled sheeting at the purlins amounted to approx. 1 kN/m. At a span of 3 m, this equivalent to a uniform distributed load of 0.66 kN/m² being applied to the profiled roof-sheet.

4.2 Torsional Moment

The purlins are connected to levers on both sides. The torque necessary to cause distortion of the purlins was achieved by suspension of weights at the cantilevers. The loading of the cantilevers took place only at the fixed-end (see fig. 3), as load-introduction at both purlins would only result in a different moment-distribution in direction of the roof-sheet span. Assuming the connection between profiled roof-sheet and purlin to be rigid, this proportion of the deflection in the roof-skin can easily be established via the flexural stiffness of the sheets.

The torque was bi-directionally applied, alternating and of increasing magnitude, so that the graphical analysis resulted in "hysteresis curves", which made it possible to establish any residual plastic deformation after cessation of load-application.

4.3 Measuring of Deformations

The torsional deformation of the purlin was measured at both ends as well as at mid-span. Additionally, for checking-purposes, the rotation of the torsion inducing cantilevers as well as the deflection of the profiled sheeting at mid-span were recorded. All deformations encountered during the test were measured by application of mechanical dials.

5. TEST RESULTS

5.1 Evaluation of the Moment-Rotation-Diagrams

For each test, a moment-rotation-diagram was prepared, in which the mean-values of distortion \mathcal{S} [rad] were logged at the abscissa, and at the ordinate the value of the torque m_t [kNm/m] applied per width unit of the roof-skin. The torsional restraint coefficient $c_{\mathcal{S}}$ can be read directly from the incline of the curve.

The diagram shows that the increase in distortion is non-linear to the moment applied. For practical application, it is not recommended to use a torsional bearing which is dependent on the load applied. Therefore, in simplification, $c_{\mathcal{S}}$ is being determined as radial-torsional resistance $\mathcal{S}=0.100$ [rad]. In the event of distortion during a test amounting to less than $\mathcal{S}=0.100$, the curve is being extrapolated with the incline between the last two measured values.

Fig. 4 reflects the evaluation of a test with thermal insulation.

The fixing was located in the bottom-chord in alternate troughs.

The points leading to the determination of the results $c_{\mathcal{S}1}$ for positive and $c_{\mathcal{S}2}$ for negative distortion are marked thus \odot in the diagram.

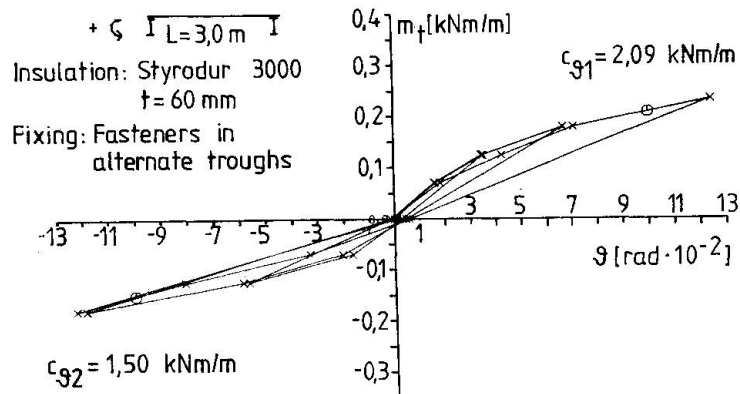

Fig. 4 Example of the graphical evaluation

5.2 Mathematical Model for the Determination of the Rigidity of the Connections

The elastic distortion of the purlin, resulting from torsional loading, consists of a bending-deflection of the profiled sheeting in direction of its span (theoretical value when assuming a rigid connection), the cross-sectional deformation of the purlin itself, and a local deformation-component in the connection (connection-stiffness). As described in [6], this can be assumed as a system of multiple, interacting torsional springs.

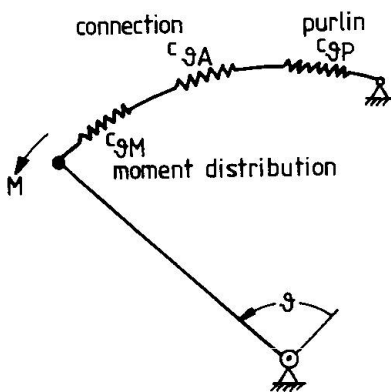

Fig. 5 Spring-Model

The connection-stiffness c_{gA} can be calculated from the cumulative deformation, as follows:

$$\frac{1}{c_{gA}} = \frac{1}{c_{gVers}} + \frac{1}{c_{gM}} + \frac{1}{c_{gP}} \quad (1)$$

$c_{gVers} \hat{=}$ the value c_{g1} and c_{g2} respectively (see diagram) as measured in the test

$c_{gA} \hat{=}$ rigidity of connection, dependent on no. of screws, sheet-thickness, ϕ of washers, thermal insulation etc.

$c_{gM} \hat{=}$ theoretical value on assuming rigid connection:
 $= K \frac{EI}{a}$ $K=f(M)$ see [3], [6]

Due to the introduction of torque into the purlins during these tests, c_{gP} assumes infinite value.

Since the tests were conducted on a roof-section (width of sheet = 1.83 m), the number of fixing-studs per metre of sheet-width was not always representative of that in an infinitely wide bay. To facilitate a better comparison of the results, the values of the torsional bearing were re-calculated to be representative for an infinitely wide profiled sheeting with even distribution of the fixing-studs. It was here presumed that the torsional bearing-values are significantly dependent on the tightening force exerted on the studs (deformation of the sheet due to application of the tightening-force), and this again is proportional to their distance from the compression-edge of the purlin.



5.3 Statistical Evaluation

The number of tests conducted with individual fastening-types was insufficient to facilitate a representative statistical evaluation. However, in order to enable the test-results with the various types of fastening systems to be combined and to obtain a working-basis for the assessment of the stress-related influences, the torsional bearing values $c_{\mathcal{J}A}$ for fixing in the bottom-chord at alternate troughs and with thermal insulation thickness $t=60$ mm installed between sheet and purlin, were considered. The standard deviation in 6 torsional restraint coefficient values amounted to: $s=0.1 \bar{m}$ (\bar{m} = mean-value).

This value is being applied in approximation for the evaluation of all tests, as the causes for the standard deviation can basically be found in the inaccuracies in the sheeting being fitted to the purlins.

Table 1 shows the resultant mean-values $c_{\mathcal{J}A,m} = \bar{m}$, as well as the fractile values $c_{\mathcal{J}A} = \bar{m} - 2 \times s = 0.8 \times \bar{m}$ of the individual fixing-designs. As the tests are being continued, it is feasible that the finally proposed values might be slightly different from those shown in table 1.

Table 1 torsional restraint coefficients with applied external loading, for profiled sheeting 40 x 183 x 0.75 in inverted installation
 - lower limiting values $c_{\mathcal{J}A}$
 - mean values $c_{\mathcal{J}A,m}$

type of connection	$c_{\mathcal{J}A}$ [kNm/m]	$c_{\mathcal{J}A,m}$ [kNm/m]
without thermal insulation bottom chord, $e=2b_r$; ϕ 19 washer	1.3	1.6
without thermal insulation bottom chord, $e=2b_r$; ϕ 29 washer	1.5	1.9
without thermal insulation bottom chord, $e=b_r$; ϕ 19 washer	2.1	2.6
without thermal insulation bottom chord, $e=b_r$; ϕ 29 washer	2.7	3.4
without thermal insulation top chord, $e=2b_r$;	3.4	4.3
without thermal insulation top chord, $e=b_r$	7.1	8.9
with Styrodur 3000 g, $t=60$ mm bottom chord, $e=2b_r$; ϕ 19 washer	1.7	2.1
with Styrodur 3000 g, $t=60$ mm bottom chord, $e=b_r$; ϕ 19 washer	2.6	3.3
with Styrodur 3000 g, $t=60$ mm top chord, $e=2b_r$	1.9	2.3
with Styrodur 3000 g, $t=60$ mm top chord, $e=b_r$	3.0	3.8

6. APPLICATION OF THE TESTRESULTS

Table 1 constitutes a summary only of the connection-stiffnesses which result from the local connection of roofing-skin to the purlin. For proof of stability, however, the in para. 5.2 listed influences need to be considered:

$$\frac{1}{c_g} = \frac{1}{c_{gA}} + \frac{1}{c_{gM}} + \frac{1}{c_{gP}} \quad (2)$$

Example:

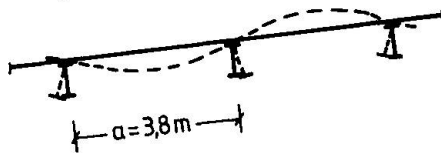

--- line of deflection

Roof Centre-Section
 profiled sheeting 40 x 183 x 0.75 mm
 $I_{eff} = 21.62 \text{ cm}^4/\text{m}$
 inverted installation
 Fixing in each bottom-chord
 ϕ 19 mm washers
 thermal insulation Styrodur 3000, $t=60 \text{ mm}$
 Purlins IPE 140, Web $t=4.7 \text{ mm}$

$$c_{gM} = \frac{4 \cdot EI_{eff}}{a} = \frac{4 \cdot 21000 \cdot 0.216}{380} = 47.7 \text{ kNm/m}$$

$$c_{gP} = \frac{E \cdot s^3}{4 \cdot h} = \frac{21000 \cdot 0.47^3}{4 \cdot 13.3} = 41.0 \text{ kNm/m}$$

$$c_{gA} = 2.6 \text{ kNm/m}$$

$$\frac{1}{c_g} = \frac{1}{47.7} + \frac{1}{41.0} + \frac{1}{2.6} \quad c_g = 2.3 \text{ kNm/m}$$

It is recognizable that the influence of the deformation of the profiled sheeting itself and the cross-sectional deformation of the purlins is negligible. This cross-sectional deformation of the purlins can, however, be significant in thin-walled sections.

For the further proof of the stability of the purlin when subjected to imposed loading the torsional restraint coefficient of $c_g=2.3 \text{ kNm/m}$ should be taken into account.

If the here established values are to be applied to profiled sheets of different dimensions, the following needs to be taken into consideration:

The location and pitch of the fixing-studs must be similar to those in the test. The significant parameters in this context are the pitch e , diameter of washers and the location of the fixing in trough or ridge of the sheeting. Sheet thickness t must be at least the same as of the sheet used in these tests and possibly used thermal insulation must be of equivalent rigidity. Further tests, including roof-construction of cold-formed purlins, are presently in progress at the Technical University Berlin.

7. ACKNOWLEDGEMENTS

The aforementioned results represent interim-results of a research-project commissioned by the Studiengesellschaft für Anwendungstechnik von Eisen und Stahl e.V., Düsseldorf, with financial support from AIF funds, for which we express our gratitude. We are indebted to the Working Group within the Studiengesellschaft for their support and assistance and to Arbed Saarstahl Co, Grünzweig und Hartmann PLC and EJOT Structural Fasteners Ltd for the supply of materials.



Literature:

- [1] Fischer, M.: Zum Kipp-Problem von kontinuierlich seitlich gestützten I-Trägern. (The buckling-problems in continuously transverse supported I-beams). Der Stahlbau 45(1976), S.120-124.
- [2] Petersen, L.: Statik und Stabilität der Baukonstruktionen. (Stressing and Stability of Building Structures). Friedr. Vieweg & Sohn, 1980.
- [3] Roik, Carl, Lindner: Biegetorsionsprobleme gerader dünnwandiger Stäbe. (Problems of Bending and Torsion in straight, thinwalled Components). Verlag Wilhelm Ernst & Sohn, Berlin, München, Düsseldorf, 1972.
- [4] Errera, J.S., Apparao, T.V.S.R.: Design of I-Shaped Beams with Diaphragm Bracing. ASCE, Vol.102, NoSt 4, April 1976, pp.769-781
- [5] Wunsch, A.: Der Einfluß von Unterwind-Belastung auf Z-Pfetten bei einer Dacheindeckung aus Wellasbestzementplatten. (The Influence of up-lift Wind Loads on Z-Purlins at Roof Sheeting by corrugated Asbestos-Cement). Dissertation, Berlin 1974.
- [6] Lindner, J., Kurth, W.: Ermittlung von Drehbettungsbeiwerten bei Unterwind. (Torsional Restraint Coefficients by up-lift Wind Loads). Versuchsbericht VR 2021 des Instituts für Baukonstruktionen und Festigkeit der TU Berlin, Berlin 1979. Bauingenieur 55(1980), S.365-369.
- [7] Forschungsvorhaben P 134: Drehbettungswerte für Dacheindeckungen mit untergelegter Wärmedämmung. (Torsional Restraint Coefficients for Roofing with Thermal Insulation between Purlin and Roof-Skin). Studiengesellschaft für Anwendungstechnik von Eisen und Stahl e.V. Düsseldorf.