

Ultimate strength of composite cold-formed steel-concrete columns

Autor(en): **Abdel-Sayed, George / Chung, Kwok-Cheung**

Objekttyp: **Article**

Zeitschrift: **IABSE reports = Rapports AIPC = IVBH Berichte**

Band (Jahr): **49 (1986)**

PDF erstellt am: **23.07.2024**

Persistenter Link: <https://doi.org/10.5169/seals-38316>

Nutzungsbedingungen

Die ETH-Bibliothek ist Anbieterin der digitalisierten Zeitschriften. Sie besitzt keine Urheberrechte an den Inhalten der Zeitschriften. Die Rechte liegen in der Regel bei den Herausgebern.

Die auf der Plattform e-periodica veröffentlichten Dokumente stehen für nicht-kommerzielle Zwecke in Lehre und Forschung sowie für die private Nutzung frei zur Verfügung. Einzelne Dateien oder Ausdrucke aus diesem Angebot können zusammen mit diesen Nutzungsbedingungen und den korrekten Herkunftsbezeichnungen weitergegeben werden.

Das Veröffentlichen von Bildern in Print- und Online-Publikationen ist nur mit vorheriger Genehmigung der Rechteinhaber erlaubt. Die systematische Speicherung von Teilen des elektronischen Angebots auf anderen Servern bedarf ebenfalls des schriftlichen Einverständnisses der Rechteinhaber.

Haftungsausschluss

Alle Angaben erfolgen ohne Gewähr für Vollständigkeit oder Richtigkeit. Es wird keine Haftung übernommen für Schäden durch die Verwendung von Informationen aus diesem Online-Angebot oder durch das Fehlen von Informationen. Dies gilt auch für Inhalte Dritter, die über dieses Angebot zugänglich sind.

Ultimate Strength of Composite Cold-Formed Steel-Concrete Columns

Résistance ultime des colonnes mixtes composées de profilés formés à froid et de béton

Traglast von Verbundstützen, zusammengesetzt aus kaltverformten Profilen und Beton

George ABDEL-SAYED

Professor
University of Windsor
Windsor, ON, Canada



Dr. Eng. G. Abdel-Sayed, born in 1933, is a graduate of Cairo University and the Technical University of Karlsruhe, FR Germany. He is involved in research and design of cold-formed steel structures and composite soil-steel structures.

Kwok-Cheung CHUNG

Structural Engineer
Wilson, Dario & Associates
Windsor, ON, Canada

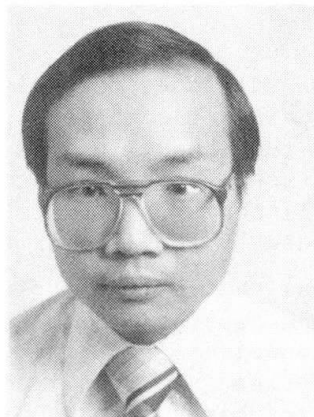

K.C. Chung, born in 1951, is a graduate of the University of Windsor in both Civil Engineering and Commerce. He is active in the field of design of steel and reinforced concrete structures. He also worked for two years as a Research Assistant at the University of Windsor.

SUMMARY

A new system of composite columns is developed using lipped cold-formed steel channels with embossments and cast-in-place concrete. The combined action of the embossments and the channel's lips leads to very good bond characteristics between the steel and the concrete. Experimental study shows that by replacing the standard longitudinal reinforcing bars by cold-formed steel sections of equal areas, the structural performance of the columns is almost unchanged, while considerable savings are achieved in time and material of construction.

RÉSUMÉ

Cette contribution concerne le développement d'un nouveau type de colonnes mixtes composées de profilés minces formés à froid, dont les ailes ont des rebords et l'âme des bosselages, et de béton coulé sur place. L'action conjuguée des bosselages et des rebords conduit à une très bonne solidarisation entre l'acier et le béton. Une étude expérimentale montre qu'en remplaçant l'armature longitudinale classique d'une colonne en béton armé par des profils formés à froid de même aire, la capacité portante est conservée, alors que des économies considérables sont réalisées en temps et matériaux de construction.

ZUSAMMENFASSUNG

Der vorliegende Beitrag befasst sich mit einer neuen Art von Verbundstützen, die aus kaltverformten Profilen und Ortsbeton bestehen. Der Querschnitt der Profile ist \square -förmig ausgebildet, wobei die Flanschen an ihren Enden nach innen abgebogen sind und der Steg eingepresste Nocken und Rillen aufweist. Die kombinierte Wirkung infolge abgegebener Flanschen und eingepresster Unebenheiten führt zu einem sehr guten Verbund zwischen Profil und Beton. Experimentelle Untersuchungen zeigen, dass die Traglast einer Stütze beim Ersatz der herkömmlichen Längsbewehrung durch ein kaltverformtes Profil fast unverändert bleibt, während wesentliche Einsparungen an Zeit und Material erzielt werden können.



INTRODUCTION

A new system of beams has been developed in which the standard reinforcing bars are replaced by cold-formed steel sections of equal areas [1]. The structural performance of these beams is almost unchanged while saving is achieved in the cost and time of construction.

The present paper deals with a similar system which is applied to build composite columns with cold-formed steel channels placed at two parallel faces, Fig. 1. Herein, considerable savings are achieved in time and material of construction due to the elimination of the steel ties in the column as well as reduction in the form work.

The present paper outlines the main characteristics of the proposed composite columns, as well as an experimental program directed mainly at examining the ultimate load carrying capacity of these columns.

BOND MECHANISM

Steel in the form of stiffened channels with embossments, Fig. 1a performed well as integral parts of composite columns, Fig. 1b. The combined action of the embossments and the channel's lips lead to very good bond characteristics between the steel channel and the concrete. This can be explained, that the concrete has to be lifted up in order to slide over the embossments, while this movement is restrained by the lips of the channel.

By acting as integral part of the column, the channels are prevented from buckling in a mode separate of the column. Therefore, no local supports are required for the channels as in the case of standard reinforced concrete columns in which ties are required in order to avoid local buckling of the individual reinforcing bars.

ANALYSIS

The proposed composite columns are built with the steel components placed at the outside surface of the section, Fig. 1b. Therefore, the compression strain at failure is governed by the yield strain of the steel (usually 0.0015 to 0.002) rather than by the concrete strain at failure (0.003). Therefore, the ultimate strength analysis of the composite column should be based on a trapezoidal shape for the compressive stress block (Jensen's theory [3]). This assumption is the main difference between the composite analysis and that of standard reinforced concrete columns. The latter analysis assumes Whitney's rectangular stress block on the compressive side.

With proper bond between the concrete and channel, strain compatibility is assumed for the analysis of the column. Herein, the ultimate load, P_u , acting at an eccentricity, e , may be computed using the assumed trapezoidal stress block and the equilibrium and compatibility conditions. Details of the analysis of the composite columns are given by Chung [2].

EXPERIMENTAL PROGRAM

An experimental program has been conducted in order to study the behaviour of the proposed composite columns, Fig. 1b.

The dimensions of the tested columns were limited by the load carrying capacities of the available laboratory facilities. The columns were cast vertically to simulate the actual construction process. A minimum dimension of 152 mm (6 in.) was chosen in order to provide clear passage for the vibrator. The steel channel has the following dimensions: $b = 152$ mm (6 in.); $h' = 50.8$

Table 1 Summary of Tests on the Proposed Composite Columns

Column		Eccentricity mm	Steel		Concrete	Ultimate Load			Expt. Bond Strength (kN)				Remark
No.	Type		t	Fy	f' _c	Expt.	Theor.	Expt.	Initial Slip		Ultimate		
			mm	MPa	MPa				kN	kN	Theor.	Total	
<u>Eccentrically Loaded Columns</u>													
A1	U	105	1.83	361	43.4	280	304	92.1%	---	---	---	---	Premature bond failure Did not fail Premature concrete crushing Tension steel yielded Comp. steel buckled Local buckling of comp. steel Local buckling of comp. steel Bond failure
A2	U	26.2	1.91	446	54.8	---	---	---	---	---	---	---	
A2*	U	50	1.91	446	54.8	420	715	58.7%	---	---	---	---	
A3	B	203.2	1.83	361	37.0	130	127	102.4%	---	---	---	---	
A4	B	105.5	1.83	361	48.9	320	324	98.8%	---	---	---	---	
A5	B	50.8	1.83	361	47.6	533	576	92.5%	---	---	---	---	
A5*	B	203.2	1.83	361	47.6	120	128	93.8%	---	---	---	---	
<u>Axially Loaded Columns</u>													
B1	B	0	1.83	361	34.3	993	1028	96.6%	---	---	---	---	565 mm long. Gradual failure in concrete and steel 1220 mm long. Sudden comp. failure
B2	B	0	1.83	361	32.7	844	978	86.3%	---	---	---	---	
<u>Pull-out Test Columns</u>													
C1	B	0	1.83	361	32.9	---	---	---	70	11.67	177	29.26	---
C2	B	0	1.83	361	32.9	---	---	---	73	12.15	180	30.0	---
C3	B	See remark	1.83	361	34.8	---	---	---	111	13.89	210	26.25	Applied load 20 mm off centre
C4	B	0	1.83	361	34.8	---	---	---	120	15.0	183	22.9	
C5	B	0	1.83	361	35.2	---	---	---	120	12.0	260	26.0	---
C6	B	0	1.83	361	35.2	---	---	---	110	11.0	264	26.4	---

U = Unbattened columns

1 in. = 25.4 mm

B = Battened columns

1 kip = 4.448 kN

1 k.s.i. = 6.895 MPa

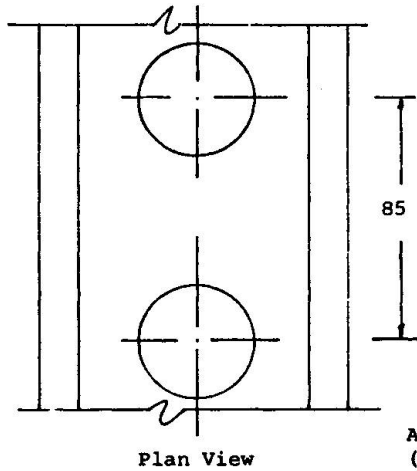
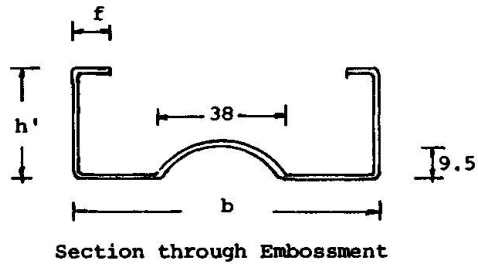

All dimensions in mm.
(1 in. = 25.4 mm)

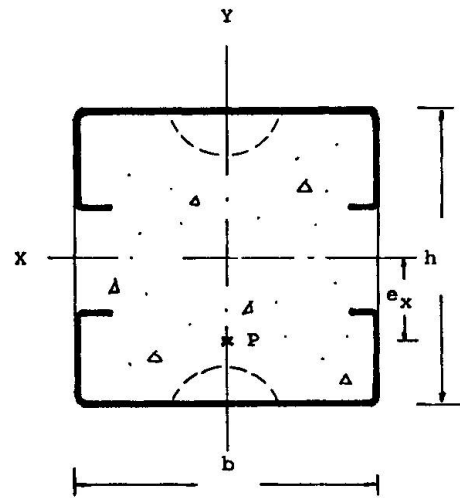

Fig. 1(a) Channels with Round Embossments Fig. 1(b) Proposed Composite Column

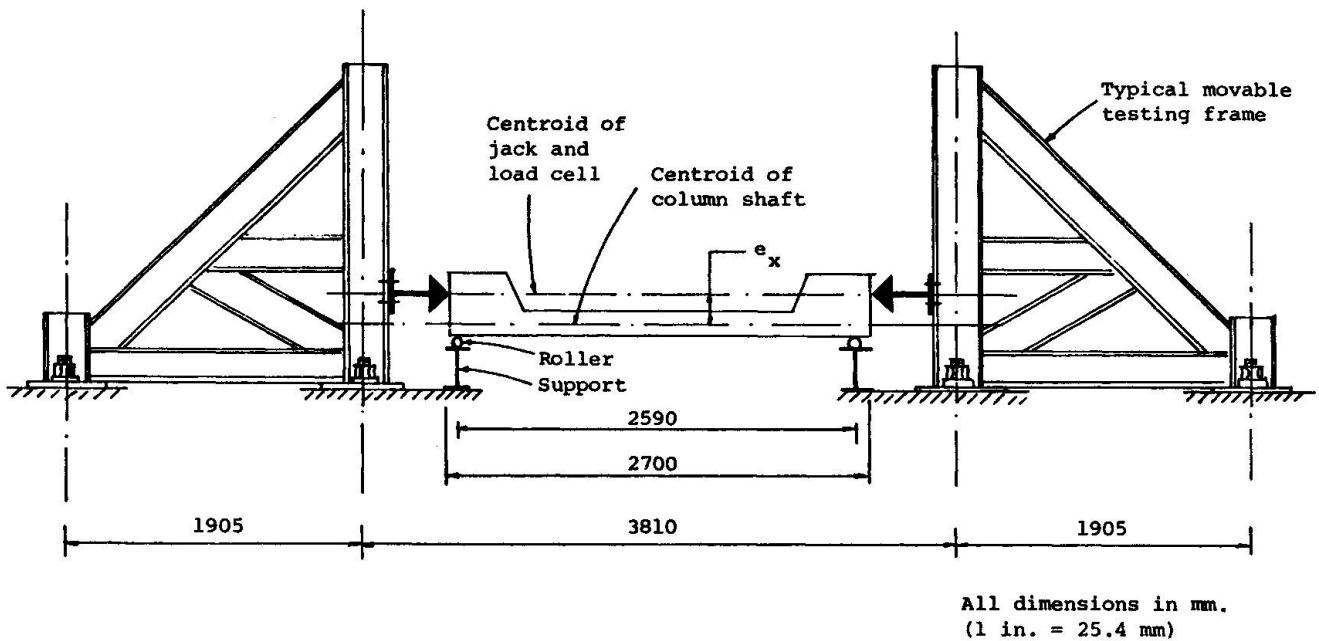

Fig. 2 Set-up of Testing Eccentrically Loaded Columns

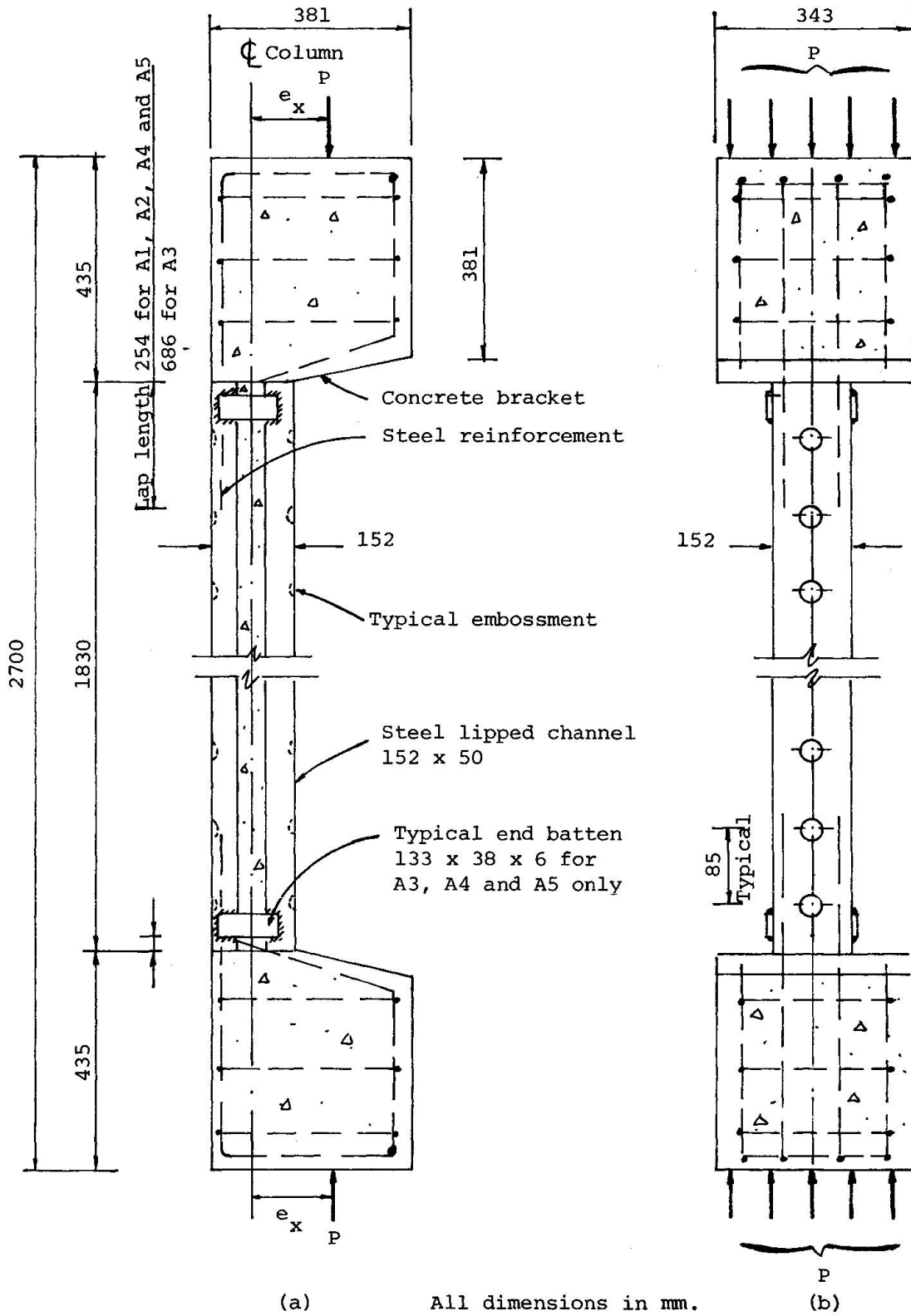
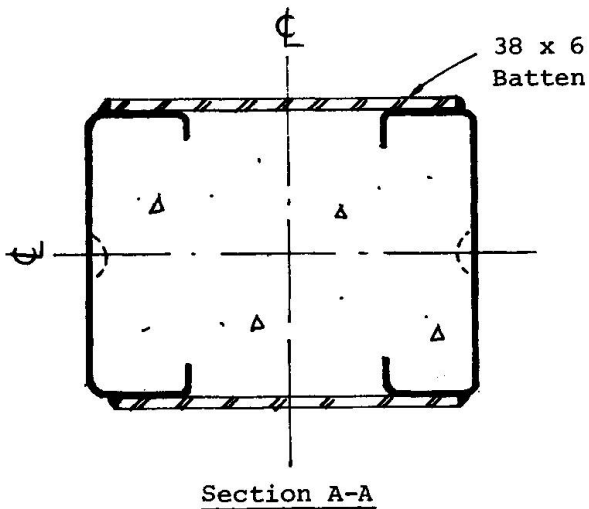
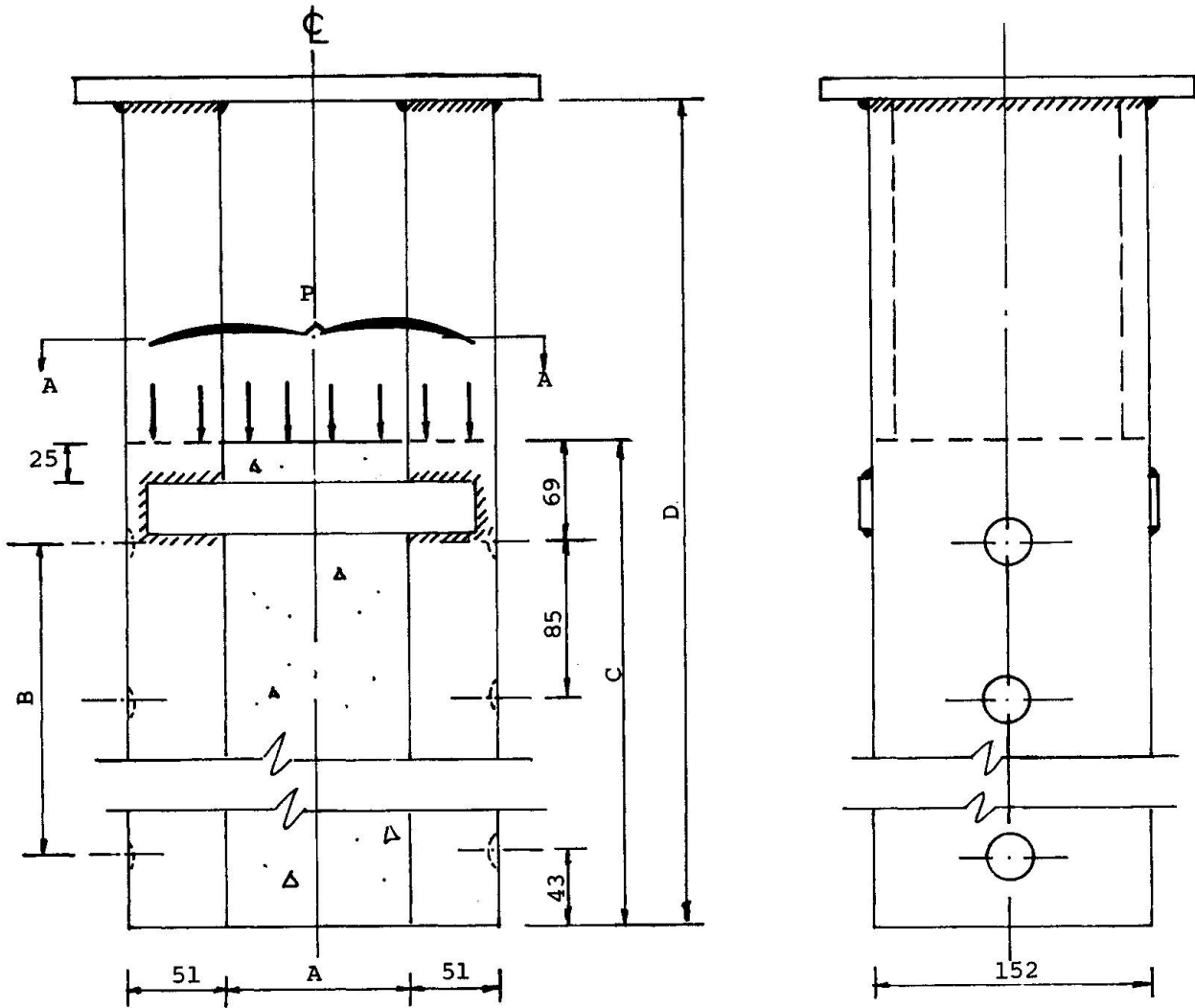

Fig. 3 Typical Eccentrically Loaded Column (Group A)



Column	Total No. of Embossments	A	B	C	D
C1 C2	2 x 3 = 6	51	172	284	457
C3 C4	2 x 4 = 8	152	257	369	737
C5 C6	2 x 5 = 10	152	343	455	813

All dimensions in mm.
(1 in. = 25.4 mm)

Fig. 4 Typical Pull-out Test Column (Group C)

mm (2 in.); $f = 12.7$ mm (0.5 in.); $t = 1.83$ mm (0.072 in.). The concrete and steel material properties are listed within Table No. 1.

The test specimens are identified by A and B for the eccentrically and axially loaded columns, respectively; and by group C for the pull-out tests. All columns except A_1 and A_2 are provided with two battens at each end, Fig. 3.

Column Tests

The experimental set-up is shown in Fig. 2 while the details of the eccentrically loaded columns are outlined in Fig. 3. Axially loaded columns were built without the end concrete brackets. Strain gauges were placed on the outside face of the exterior channels around an embossment near the mid height of the column. Dial gauges were used to measure the in-plane and lateral mid-height deflections.

Table 1 presents a summary of the ultimate strength of the eccentrically and axially loaded columns. The following has been observed through the test program and by examining Table 1:

- 1 - Comparison between the ultimate load of the tests $A_{1,2}$ and the tests A_3 to A_5 , show that the end battens improve the failure mode and the load carrying capacity of the composite columns. The failure is gradual with end battens, while undesirable sudden split caused the failure in columns with no end battens.
- 2 - Failure of most of the columns was triggered by yielding of the steel section which was observed as the channel web got crippled in the zone between embossments at the compression side. This confirms the assumption that the ultimate load is governed by the yield strain of the steel which is usually lower than the failure strain of concrete (0.003). The ultimate load calculated on the bases of these assumptions is found to be in good agreement with the experimentally obtained load.
- 3 - The combined action of the embossment and the channel's lip lead to very good bond between the channel and the concrete. However, sufficient length of splice should be provided in order to prevent the premature failure at the beam-column connections, as in Test No. A5 (Table 1). This length is determined from pull-out bond tests.

Pull-out Tests

The pull-out test, Fig. 4, is conducted with dial gauges mounted to record any relative displacement (slit or slip) between the concrete and steel. At the pull-out failure, the concrete is displaced forcing the steel to bulge outwards. The concrete surface is scratched by the moving steel embossment. The width and depth of the scratches is maximum near the fully stressed steel section and decreases at the embossments near the stress free end. Such phenomena can explain the observation that the bond strength does not increase proportionally with the increase of number of embossments, Table 1.

CONCLUSION

Lipped channels with embossments performed very well as integral parts of composite columns. No ties were required to prevent the channels from buckling independently of the column leading to savings in time and material of construction. The ultimate load carrying capacity is found to be governed by the yield strain of the steel on either the tension or the compression side.



REFERENCES

1. ABDEL-SAYED, G., Composite Cold-Formed Steel-Concrete Structural System, Proceedings, 6th Specialty Conference on cold-Formed Steel Structures, St. Louis, Missouri.
2. CHUNG, K.C., "Behavior of Composite Concrete Columns With Cold-Formed Steel", M.Sc. Thesis, Dept. of Civil Eng., Univ. of Windsor, Windsor, Ontario, Canada, 1985.
3. JENSEN, V.P., The Plasticity Ratio of Concrete and Its Effect on the Ultimate Strength of Beams, ACI Journal, Vol. 14, No. 6, June 1943, pp. 565-582.
4. LIN, T.Y. and LAKHWARA, T.R., Ultimate Strength of Eccentrically Loaded Partially Prestressed Columns, PCI Journal, Vol. 11, No. 3, June 1966, pp. 37-49.