

Additional insulation of flat roofs with thin-walled metal structures

Autor(en): **Höglund, Ingemar / Andersson, Patrick**

Objektyp: **Article**

Zeitschrift: **IABSE reports = Rapports AIPC = IVBH Berichte**

Band (Jahr): **49 (1986)**

PDF erstellt am: **23.07.2024**

Persistenter Link: <https://doi.org/10.5169/seals-38324>

Nutzungsbedingungen

Die ETH-Bibliothek ist Anbieterin der digitalisierten Zeitschriften. Sie besitzt keine Urheberrechte an den Inhalten der Zeitschriften. Die Rechte liegen in der Regel bei den Herausgebern.

Die auf der Plattform e-periodica veröffentlichten Dokumente stehen für nicht-kommerzielle Zwecke in Lehre und Forschung sowie für die private Nutzung frei zur Verfügung. Einzelne Dateien oder Ausdrucke aus diesem Angebot können zusammen mit diesen Nutzungsbedingungen und den korrekten Herkunftsbezeichnungen weitergegeben werden.

Das Veröffentlichen von Bildern in Print- und Online-Publikationen ist nur mit vorheriger Genehmigung der Rechteinhaber erlaubt. Die systematische Speicherung von Teilen des elektronischen Angebots auf anderen Servern bedarf ebenfalls des schriftlichen Einverständnisses der Rechteinhaber.

Haftungsausschluss

Alle Angaben erfolgen ohne Gewähr für Vollständigkeit oder Richtigkeit. Es wird keine Haftung übernommen für Schäden durch die Verwendung von Informationen aus diesem Online-Angebot oder durch das Fehlen von Informationen. Dies gilt auch für Inhalte Dritter, die über dieses Angebot zugänglich sind.

Additional Insulation of Flat Roofs with Thin-Walled Metal Structures

Amélioration de l'isolation de toitures plates à revêtement métallique
à parois minces

Zusatzisolierung von Flachdächern mit dünnwandigen
Metallkonstruktionen

Ingemar HÖGLUND

Prof. Dr.
Royal Inst. of Technology
Stockholm, Sweden

Patrick ANDERSSON

Civil Eng.
Royal Inst. of Technology
Stockholm, Sweden

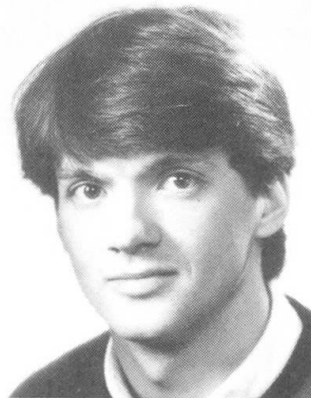

The authors are with the Royal Institute of Technology in Stockholm. I. Höglund is professor and head of the Division of Building Technology (from 1972). He has published extensively in the field of building science and energy conservation and participates in international collaboration. P. Andersson is a research assistant in the same Division.

SUMMARY

Rebuilding and improving the insulation of flat roofs by conventional methods at present leads to both technical and cost problems. For several reasons it is an attractive solution to place additional insulation directly on top of the outer surface of the roof. From a building physics point of view there is at the same time both improved moisture control and improved thermal resistance. The report analyses the pros and cons of this method. Comparisons are made with more conventional rebuilding methods.

RÉSUMÉ

La réfection et l'amélioration de l'isolation des toitures plates par les méthodes conventionnelles posent actuellement des problèmes d'ordre économique et technique. Pour plusieurs raisons, la solution la plus séduisante consiste à procéder à la pose de l'isolation additionnelle directement au-dessus de la surface extérieure du toit. Du point de vue physique du bâtiment, le contrôle de l'humidité ainsi que la résistance thermique se trouvent simultanément améliorés. Ce rapport analyse les avantages et inconvénients de cette méthode. Des comparaisons sont faites avec des méthodes de réfection plus conventionnelles.

ZUSAMMENFASSUNG

Umbau und Verbesserung der Zusatzisolierung von Flachdächern mit konventionellen Methoden verursachen technische und finanzielle Probleme. Man erhält eine ansprechende Lösung, wenn die Zusatzisolierung auf die Aussenseite des Daches aufgelegt wird. Vom bauphysikalischen Standpunkt wird auf diese Weise sowohl eine bessere Feuchtigkeitskontrolle als auch ein besserer Wärmewiderstand erreicht. In diesem Bericht werden die Vorteile und Nachteile dieser Methode besprochen.



1. FLAT ROOFS — INTRODUCTION

In Sweden in the fifties it became more common to build houses and public buildings with roofs with a shallow pitch of about 4° . Between 1950 and 1979 about 150 million m^2 of flat roof were built with weatherproof roofing felt but other types of roofing material, for example metal sheeting, were also used.

Many of these flat roofs are now in urgent need of renovation because:

- the weatherproof covering is old and worn and must be replaced. The life of roofing felt varies between 15-25 years depending on factors such as the method of laying and maintenance. The roofing felt on many roofs is now 20-35 years old, so replacement is necessary,
- thermal insulation is in many cases not satisfactory, being under-dimensioned by present-day standards,
- many roofs have been affected by moisture penetrating from inside and outside. Increased moisture content in roofs leads to poorer thermal insulation and an increase in mould and rot attacks.

Conventional methods of rebuilding and improving the insulation of these types of roofs have led to both technical and cost problems. Conventional methods involve i.e. removing the old roof, building up the roof trusses, adjusting the vapour barrier, putting in additional insulating material. Naturally this is a relatively expensive process.

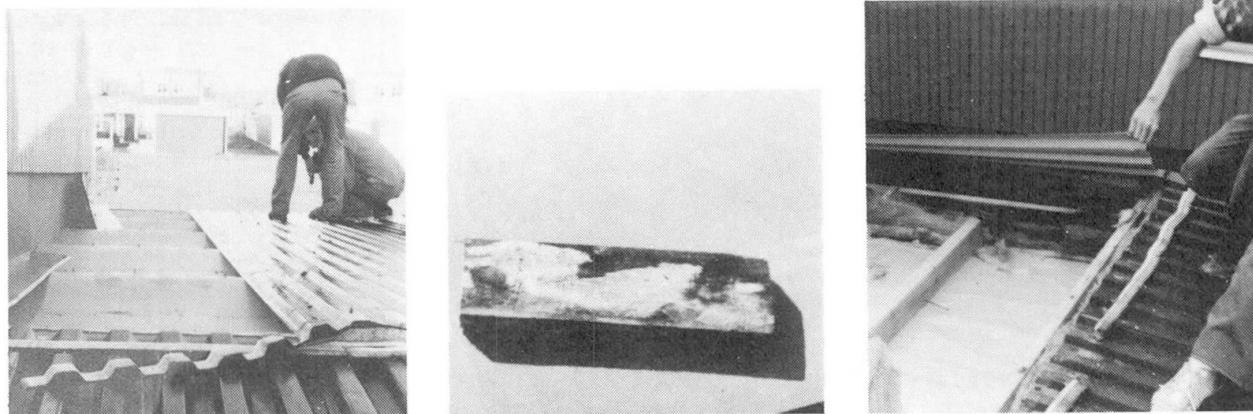

Fig. 1 Moisture damaged flat roof with metal sheeting. Moisture penetration from both the inside and the outside. The fibre board hung down, thus blocking the vented air space. The moisture content in the construction increased and caused mould and rot damage. (Example 1.)

1.1 Does external additional insulation improve the moisture level in the roof?

Now, however, it is hoped that it will be possible to solve insulation and moisture problems in a simpler way. Additional insulation is simply placed on top of the old roof. By improving the insulation in this way the work is made easier and more cost-effective.

A few buildings in Denmark and Sweden have been rebuilt in this way. If recommendations and guide lines of a more general nature are to be given, however, it will be necessary to acquire greater experience and theoretical understanding of the problems involved in rebuilding flat roofs.

In a current R & D project (financed partly by grants from the Swedish Council for Building Research) at the Division of Building Technology, RIT, Stockholm, a number of different roofs with additional insulation are being studied. These are mainly flat roofs with additional insulation placed externally. The investigation comprises both experimental and theoretical studies. Variations in

the moisture level, thermal-insulating effect, costs and cost-effectiveness are studied. Calculations and measurements are made before and after renovation. From a technical point of view the renovated construction is expected to function in the following way:

- the original roofing (with possible additions) acts as a new vapour barrier for the additional insulation,
- the additional insulation causes a rise in the temperature of the construction. This rise is dependent on the thermal resistance of the additional top insulation and the extent to which the ventilation of the roof is retained,
- the rise in temperature lowers the relative air humidity (R.H.),
- the lower R.H. causes a wood construction to dry out, i.e. the moisture ratio decreases,
- when the moisture ratio is less than about 15% (by weight) the roof ventilation is closed off to gain the full effect of the additional insulation. With moisture ratios of less than about 15% there is judged to be no risk of mould and rot damage. Regarding mould fungi marginal attacks may occur at moisture ratios below 20% for wood. A few less common types may develop at about 15%. The majority of types of mould fungi, however, require considerably higher moisture ratios than 15%.

The thermal resistance of the additional insulation is dimensioned according to constructional and cost aspects. Since the new construction has the vapour barrier inside the construction, the thickness of the additional insulation has to be decided upon so that condensation does not occur against the vapour barrier and so that the relative humidity of the air is kept at an acceptable level. As a general guide it can be said that the additional insulation should have at least the same thermal resistance as the original roof had.

Other advantages of placing additional insulation on the outside of the roof are:

- by using thermal insulating materials cut at an angle it is possible to build a steeper slope towards the drain. This leads to reduced thermal resistance and consequently increasing surface temperatures towards valleys and gutters, which improves the run-off of melting snow,
- the roof construction will not be exposed to such high surface temperatures in summer and air temperatures in the upperstorey will be lower in summer,
- the roof construction maintains a more even temperature throughout the year, which means that thermal-related movements and stresses will be reduced.

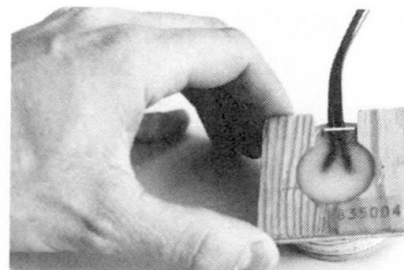
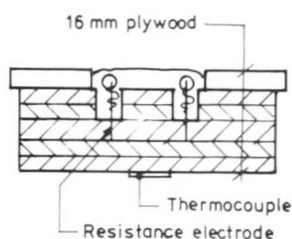

Fig. 2 Moisture-measuring gauge used in the field investigations. The gauge is built into the roof decking. The electrodes, insulated except at the tips, measure the electrical resistance of the plywood. The thermocouple helps to correct resistance measurements for temperature. By using a relation curve of electrical resistance and moisture content in the measuring gauge, it is possible to determine the moisture ratio in the measuring gauge and thereby the moisture ratio in the roof.



The drawback of the above-described method is that there is a risk that mould and rot are enclosed. It is therefore important to see to it that any affected parts are replaced before the additional insulation is laid on. This insulation will be lying between two waterproof layers, so it is very important that it is very well protected from precipitation during rebuilding.

2. FIELD STUDIES

In the following we will present some examples of damage caused by moisture in three types of flat roof with thin-walled metal sheeting and how these roofs were treated. Some theoretical and experimental results are presented.

2.1 Example 1

The investigation covered an estate of terraced houses in central Sweden built in 1973-74, comprising about 100 houses. The roof covering is metal sheeting and the pitch is only about 4° . The roof is ventilated and the ventilation is at right angles to the pitch. For the original roof construction and rebuilt roof see Figs 3 and 4. During the very first winter moisture patches appeared in the roof and walls. We established that the damage was due to moisture penetrating from both within and without.

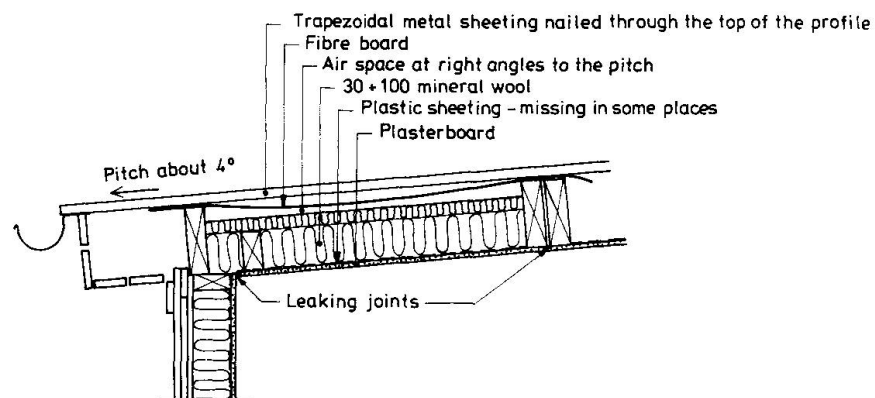

Fig. 3 The roof construction consists of prefabricated elements. Owing to leaks at the joints the inside air was able to leak into the construction, where it condensed against the metal sheeting. Outside moisture was also able to penetrate the roof. Owing to swelling from damp the fibre boarding hung down blocking the vented air space.

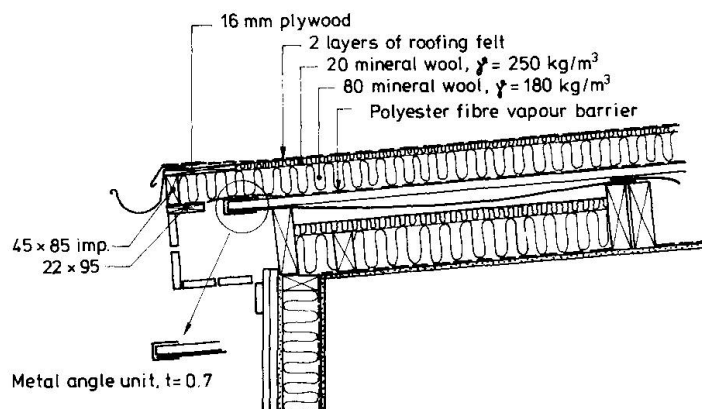

Fig. 4 Rebuilt roof. The ventilation was closed off. As the joints in the metal sheeting were not tight, a sheet of roofing felt was laid on the metal as a vapour barrier. The additional insulation was nailed on.



insulation. However, for practical and hygienic reasons the "rainfall" from the ceiling could not be tolerated. The problem was solved by using external additional insulation, see Fig. 7.

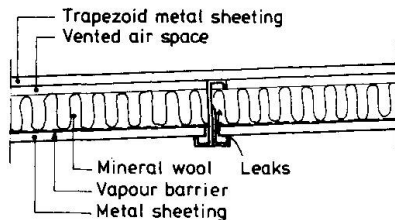

Fig. 6 Double metal sheeting roof. Warm, moist air penetrated owing to leaks between the vapour barrier and structural beams caused condensation against the outer metal sheeting during cold periods.

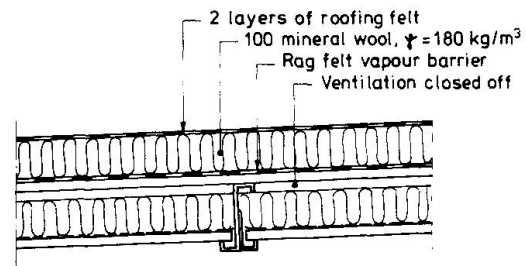

Fig. 7 Roof construction after rebuilding. A vapour barrier of rag felt was glued to the roof to prevent air convection. Dripping from the ceiling has stopped.

After additional insulation of the roof in spring 1983 dripping from the ceiling stopped and the roof now functions perfectly. Moisture and temperature are measured in the roof to check the moisture content there. See Fig. 8.

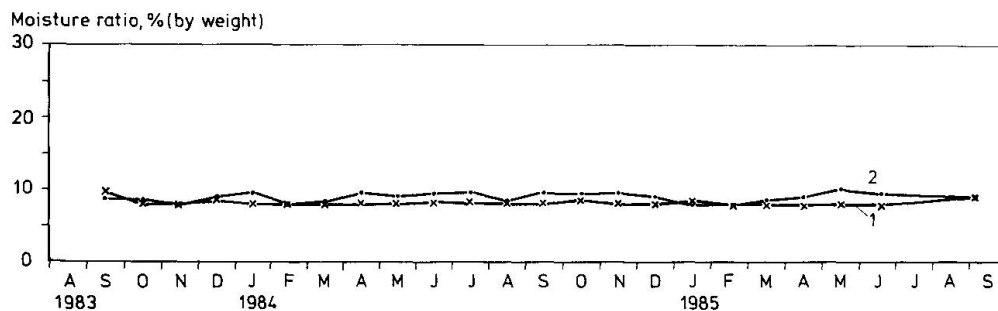

Fig. 8 Example of results. Moisture and temperature are measured both in the air space, line 1 and immediately below the new weatherproof layer, line 2. Since additionally insulating the roof the moisture ratio in the roof has remained for the whole period at a low level, c. 8% in the air space and c. 10% under the new weatherproofing. However, the moisture ratio at one of the measurement points immediately below the new weatherproofing was c. 20%, which indicates that moisture has been enclosed. Moisture is measured by means of built-in moisture-measure gauges; figures refer to the moisture ratio in these rounds.

2.3 Example 3

Example 3 comprises eight rows of terraced houses north of Stockholm. The roof is a butterfly construction consisting of two shallowly pitched (c. 0.5°) roof surfaces converging on a central line where the drainage is placed. For roof construction, see Fig. 9.

After a time moisture patches appeared on the ceilings and inner walls. The damage was caused by moisture penetrating from outside. Owing to initial shrinking and temperature movement in the polystyrene slabs gaps appeared between these slabs. The roofing felt then split above the gaps and water was able to penetrate the roof.

In summer 1984 the roofs were rebuilt as strutted roofs covered with metal sheeting. The sheeting was fastened to a steel construction which was in turn fastened to the concrete frame with expander bolts. See Fig. 10.

In order to fasten the steel construction to the concrete slab holes were cut in the weatherproofing and insulation. After raising the construction these holes were made watertight. In one row of houses the work was done unsatisfactorily, since rainwater penetrated the roof before the metal sheeting was placed in position. Thus, it is of the greatest importance that the holes are made watertight with great care, as even the smallest holes can lead to serious water leaks.

Moisture and temperature are measured in two houses, see Fig. 11.

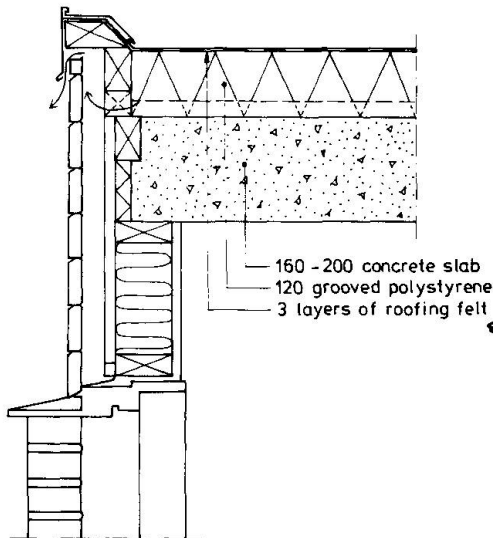

Fig. 9 Attachment to eaves of original roof.

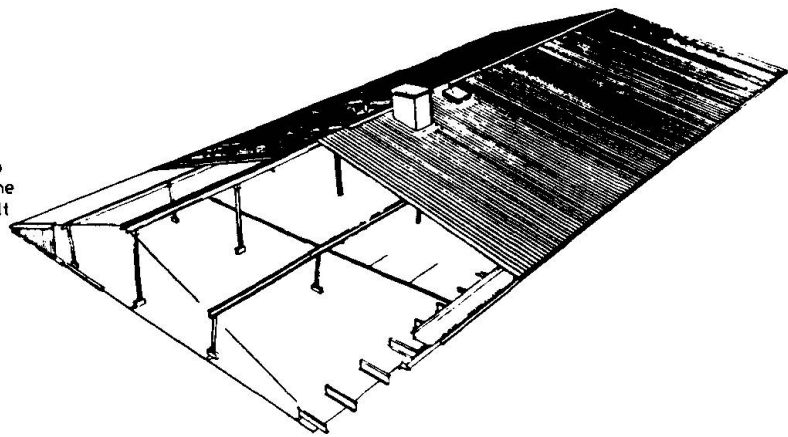

Fig. 10 New strutted outer roof of metal sheeting with a 14° pitch. The roof was additionally insulated with 120 mm of mineral wool. The original internal drainage was closed off. The new roof was provided at the eaves with guttering connected to the storm-water drainage system.

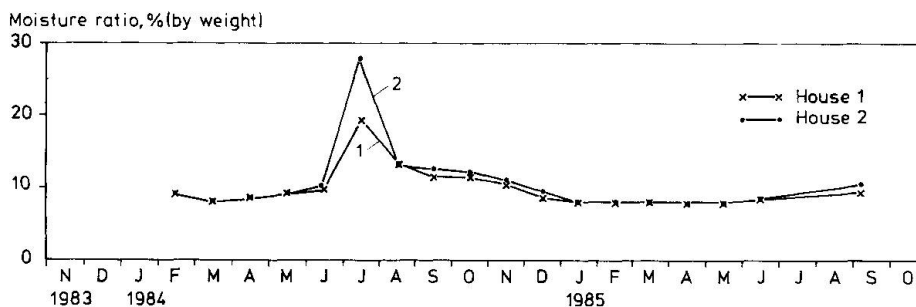

Fig. 11 Example of results. Moisture is measured by means of built-in wooden rounds placed between the concrete slab and the cellular plastic insulation. The large increase in the moisture ratio in June-July was caused by the leaks in connection with raising the steel construction. Apart from this incident the moisture ratio has remained during the whole period at an even and low level (8-10%). The moisture ratio values refer to the moisture ratio in the moisture-measuring gauges.



3. FIRE PROTECTION

The new method using external additional insulation of flat roofs with the roof ventilation closed off, has also appeared to be efficient in preventing the spread of fire. This was revealed in the autumn of 1984 when there was a fire in one of the investigated housing areas (terraced houses). After the fire, the adjacent houses remained totally intact partially because of the use of this method.



4. FLAT ROOFS CAN BE REBUILT SAFELY AND COST-EFFECTIVELY

We have reported on three investigations in the project. The buildings (with external additional insulation) which have been investigated have up to now functioned well and the results obtained indicate that practice and theory are in good agreement.

Tenders were sought for rebuilding the three buildings described in the report, using both additional insulation and a strutted roof construction. In all cases the use of the external insulation method proved to be almost 50% cheaper than using a strutted roof.

ACKNOWLEDGEMENT

The project is sponsored by the Swedish Council for Building Research.

REFERENCES

1. HÖGLUND, I. & ANDERSSON, P., Ombyggnad och tilläggsisolering av flacka tak. (Department of Building Technology, RIT.) Bulletin No. 143. Stockholm 1984.
2. KORSGAARD, V., CHRISTENSEN, G., LOHSE, U., PREBENSEN, K. & BRANDT, J., Merisolering af flade tage. (COWI Consult, Rådgivande Ingenjörer AS.) Bulletin No. 418. Copenhagen 1981.