

# Fatigue crack detection and repair of steel bridge structures

Autor(en): **Fisher, John W. / Menzemer, Craig C. / Yen, Ben T.**

Objektyp: **Article**

Zeitschrift: **IABSE reports = Rapports AIPC = IVBH Berichte**

Band (Jahr): **59 (1990)**

PDF erstellt am: **22.07.2024**

Persistenter Link: <https://doi.org/10.5169/seals-45726>

## **Nutzungsbedingungen**

Die ETH-Bibliothek ist Anbieterin der digitalisierten Zeitschriften. Sie besitzt keine Urheberrechte an den Inhalten der Zeitschriften. Die Rechte liegen in der Regel bei den Herausgebern.

Die auf der Plattform e-periodica veröffentlichten Dokumente stehen für nicht-kommerzielle Zwecke in Lehre und Forschung sowie für die private Nutzung frei zur Verfügung. Einzelne Dateien oder Ausdrucke aus diesem Angebot können zusammen mit diesen Nutzungsbedingungen und den korrekten Herkunftsbezeichnungen weitergegeben werden.

Das Veröffentlichen von Bildern in Print- und Online-Publikationen ist nur mit vorheriger Genehmigung der Rechteinhaber erlaubt. Die systematische Speicherung von Teilen des elektronischen Angebots auf anderen Servern bedarf ebenfalls des schriftlichen Einverständnisses der Rechteinhaber.

## **Haftungsausschluss**

Alle Angaben erfolgen ohne Gewähr für Vollständigkeit oder Richtigkeit. Es wird keine Haftung übernommen für Schäden durch die Verwendung von Informationen aus diesem Online-Angebot oder durch das Fehlen von Informationen. Dies gilt auch für Inhalte Dritter, die über dieses Angebot zugänglich sind.

## Fatigue Crack Detection and Repair of Steel Bridge Structures

Détection de fissures de fatigue et réparation des structures  
de ponts en acier

Entdeckung von Ermüdungsrissen und Reparaturen an Stahlbrücken

### John W. FISHER

Director  
ATLSS, Lehigh Univ.  
Bethlehem, PA, USA

Dr. Fisher, who is Director of the NSF ERC for Advanced Technology for Large Structural Systems, received his degrees from Washington University in St. Louis and Lehigh University. He was a Visiting Professor at the Swiss Federal Institute Lausanne in 1982 and was awarded Doctor Honoris Causa degree by EPFL in 1988. He is a member of the National Academy of Engineering.

### Craig C. MENZEMER

ATLSS Scholar  
Lehigh University  
Bethlehem, PA, USA

Craig Menzemer obtained a Bachelor of Science Degree and Master of Science Degree in Civil Engineering from Lehigh University. He has been involved in construction management, stress analysis, product design and testing. Currently, Craig is employed by Alcoa and is also studying for a Doctor of Philosophy in Civil Engineering.

### Ben T. YEN

Professor of Civil Eng.  
Lehigh University  
Bethlehem, PA, USA

Dr. Yen is a graduate of the National Taiwan University and received his Master of Science and Doctor of Philosophy degrees from Lehigh University. He specializes in structural engineering in the area of fatigue and fracture strength of structures and connections; buckling, strength and behavior of plate and box girders and curved bridge members, and inspection and retrofitting of bridges and structures.

### SUMMARY

Repair of fatigue damaged bridge components depends on the cause and size of the cracks. Methods include peening, hole drilling, increasing the unsupported length of the web at some connections, attaching additional components at these connections and others. Two examples are given. One is an elevated highway bridge, with cracks at connections of cross girders to columns of bents and at ends of longitudinal girders. The other is a riveted truss bridge where cracks developed at hangers.

### RÉSUMÉ

La réparation des éléments de pont ayant subi un dommage de fatigue dépend de la cause et de la dimension des fissures. Des méthodes possibles parmi d'autres sont le martelage, le percement d'un trou, l'augmentation de la longueur des couvre-joints, ou l'adjonction d'éléments de liaison supplémentaires. Deux exemples sont présentés. L'un concerne un pont d'autoroute contenant des fissures au droit des liaisons entre les traverses et les appuis, ainsi qu'aux extrémités des poutres longitudinales. L'autre exemple traite d'un pont à treillis riveté dans lequel des fissures se sont développées dans les montants.

### ZUSAMMENFASSUNG

Reparaturmöglichkeiten von ermüdungsbedingten Schäden an Brückenelementen sind abhängig von deren Ursachen und Grösse. Mögliche Methoden sind unter anderen Hämmern, Bohren von Löchern, Verlängerung von Laschen oder Anbringung zusätzlicher Verbindungselemente. Zwei Beispiele werden vorgestellt: Eines stammt von einer Hochstrasse bei der an den Verbindungsstellen der Querträger mit den Stützen und an den Enden der Längsträger Risse auftraten. Das zweite Beispiel behandelt die in den Ständern einer genieteten Fachwerkbrücke aufgetretenen Risse.



## 1.0 INTRODUCTION

Localized failures have continued to develop in steel bridge components due to fatigue crack propagation which in some instances, has led to brittle fracture [1,2]. A majority of the fatigue cracks can be placed into one of two categories. The single largest category is a result of out-of-plane distortion in small, unstiffened segments of web plates. When distortion-induced cracking develops in bridge members, large numbers of cracks develop nearly simultaneously in the structure as the cyclic stress is high and the number of cycles needed to produce cracking is relatively small. Displacement induced cracking has developed in a wide variety of structures including suspension, two girder floor beam, multiple beam, tied arch, and box girder bridges. In general, the cracks form parallel to the primary stress field and are not detrimental to the performance of the structure provided they are discovered and retrofitted before turning perpendicular to the applied stresses.

The second largest category of fatigue damaged members and components comprises large initial defects or cracks. Defects in this category usually resulted from poor quality welds produced before nondestructive test methods were firmly established. In addition, a number of localized failures in this category developed because the groove welded component was considered a secondary member or attachment. As a result, weld quality criteria were not established and nondestructive test methods were not employed. Other details develop fatigue damage because of geometry or fabrication practice.

A majority of the remaining failures resulted from the use of low strength details that were not anticipated to have such a low fatigue strength at the time of the original design because of the limited experimental database that specification provisions were based.

## 2.0 REPAIR OF FATIGUE DAMAGED COMPONENTS

Any methodology used to repair fatigue damaged details is case specific and is generally dependent on the size and location of the crack(s) at the time of repair [3]. Obviously, this is highly dependent on both the inspection procedures and the ability to locate relatively small cracks. Apart from displacement-induced cracks, the majority of fatigue cracking has resulted from low strength details, or large initial defects, or geometric conditions which simulate crack-like conditions. Figure 1 illustrates the role played by both the initial defect size and stress concentration in the determination of the relative fatigue strength of various detail categories [4].

Various methods to retrofit or increase the fatigue resistance of welded details have been employed [5]. For cracks which have propagated from normal, in-plane design stress fields, peening can be a successful repair as long as the crack depth does not exceed the depth of the beneficial compressive residual stresses which result from the peening operation [6]. Laboratory studies have shown that a fatigue crack of up to 3 mm in cover-plated details can be arrested by peening provided the stress range does not exceed 41 MPa. Also peening has been most successful when conducted under a low minimum tensile stress or dead load. Finally, peening has been found to be a reliable solution when performed in the field and has been carried out on a number of detail types.

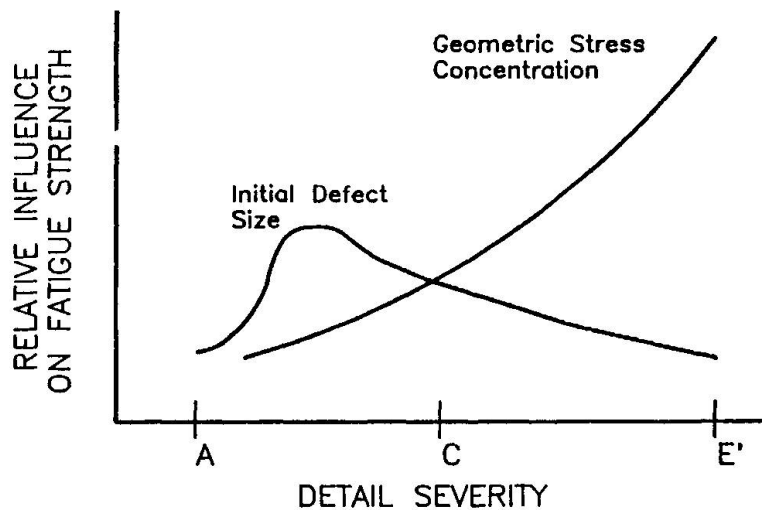

Fig. 1 Relationship Between Fatigue Strength, Detail Type and Defects

In situations where the crack has grown away from the influence of the stress concentration and is a through thickness crack, it may be successfully retrofitted with holes drilled at the crack tip [7]. Holes essentially blunt the tip of the crack, although they must be sized so as to satisfy

$$\Delta K / \sqrt{\rho} \leq A \sqrt{\sigma_y}$$

where  $\Delta K$  = stress intensity range  
 $\rho$  = radius of the hole  
 $\sigma_y$  = yield stress of the steel  
 $A^y$  = coefficient - 10.5 for  $\sigma_y$  in MPa

The validity of this repair has been studied in the laboratory on full scale welded beams subjected to constant stress range cycle and variable amplitude loading up to 90 million cycles.

Distortion induced cracking may also be retrofitted by drilling holes, although laboratory tests have shown this to be ineffective when there are high levels of distortion [8]. For multiple girder structures, most displacement induced cracking occurs in the web gap region at the end of connection plates in the negative moment region [8]. Lengthening the web gap may be effective provided that the magnitude of the out-of-plane distortion does not increase as a result of reduced detail stiffness. The most effective, and by far most costly, eliminates the distortion through positive attachment of the connection plate to the girder flange.

In situations where extensive fatigue cracking has occurred, the only reliable technique is to provide a bolted splice or connection across the damaged area.

### 3.0 I-93 CENTRAL ARTERY

The Central Artery carries traffic through Boston, Massachusetts and surrounding communities. A viaduct structure, located in the Artery's northern area, consists of bilevel rigid steel frame bents which support a two girder floor-beam stringer system on each level. Columns of the rigid bents have box section while transverse beams have either box or I sections (Fig. 2). I-beam



to column connections contain closure plates fillet welded to the edges of the I section and column flanges (Fig. 3). Webs of the I beams are groove welded to the columns while beam flanges (both box and I) and box beam webs of the lower portion of the bents are connected via full penetration groove welds with back-up bars (Fig. 4).

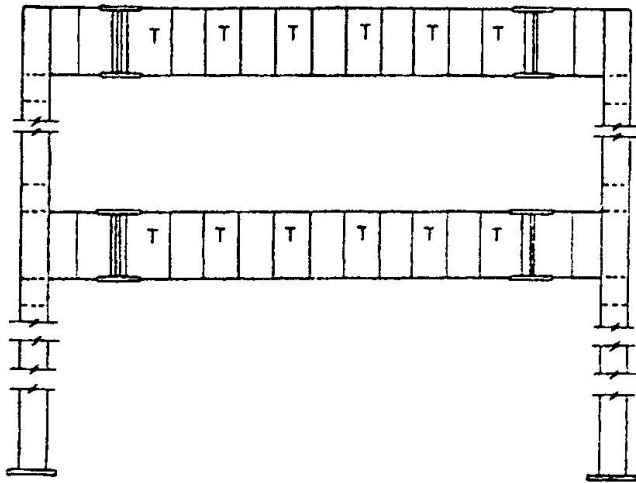

Fig. 2 Typical Bent Elevation

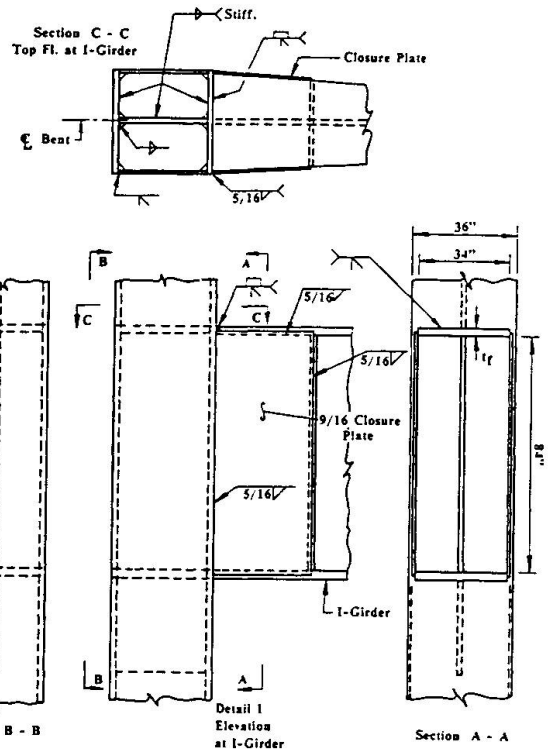

Fig. 3 Representative I-Beam to Column Connection

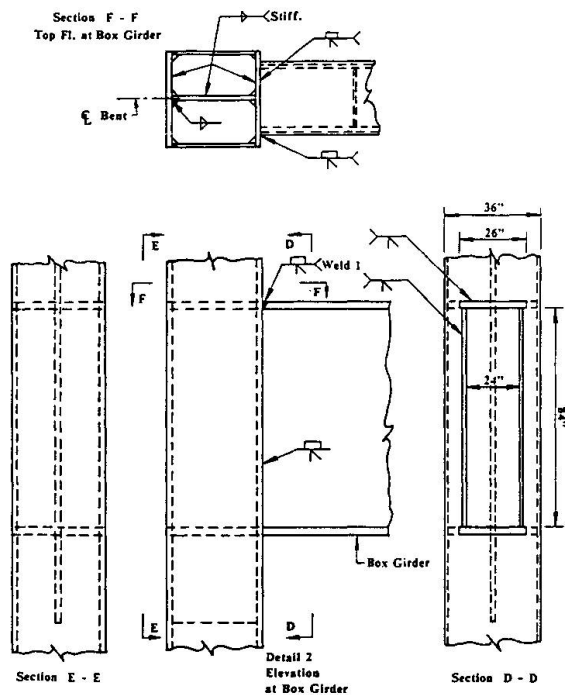

Fig. 4 Representative Box Beam to Column Connection

Beam flanges of the upper portion of the bent are continuous into the column. Cope openings in the box beam webs at the beam column connection points are covered with small plates which are fillet welded to the box beam webs [2].

For each of the two girder floorbeam systems, longitudinal girders and stringers form composite action with the reinforced concrete decks. Both top and bottom flanges of the longitudinal girders are coped by flame cutting to permit a bolted, double angle web connection with transverse beams of the bent. The connection angles are fitted to the top and bottom flanges of the transverse beams.

### 3.1 Inspection Results

Inspection of the structure revealed several areas which contained fatigue cracks. In addition, lateral displacement of several longitudinal girder bottom flanges was also observed. Fatigue cracks were found along the longitudinal girder web to flange weld at the flange terminations and vertical cracks were observed in the longitudinal girder webs at the reentrant corner of the bottom copes (Fig. 5). Cracking was occasionally observed along the bolt fixity line of the connection angles (Fig. 6).



Fig. 5 Vertical and Horizontal Fatigue Cracks at Bottom Web Cope

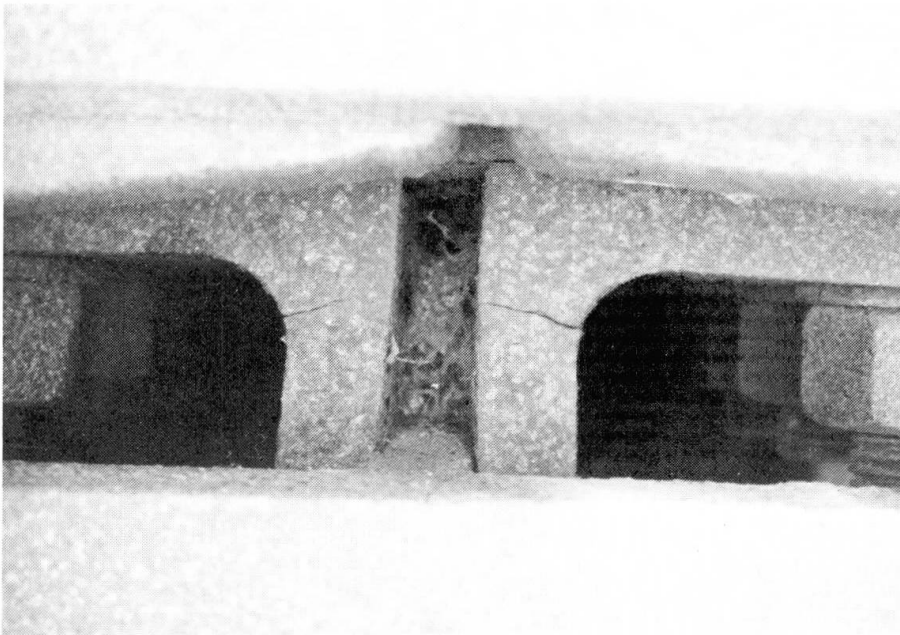

Fig. 6 Cross-Sectional View of Angle with Fatigue Cracks



Figure 7 shows cracks which extended several inches along the bottom end of the angle fillet, between the girder web and the transverse beam of the bents. The cracks were found only at locations where the longitudinal girder web was bolted full depth to the connection angles. Other locations where the girder web was not bolted full depth exhibited no evidence of cracking (Fig. 8).

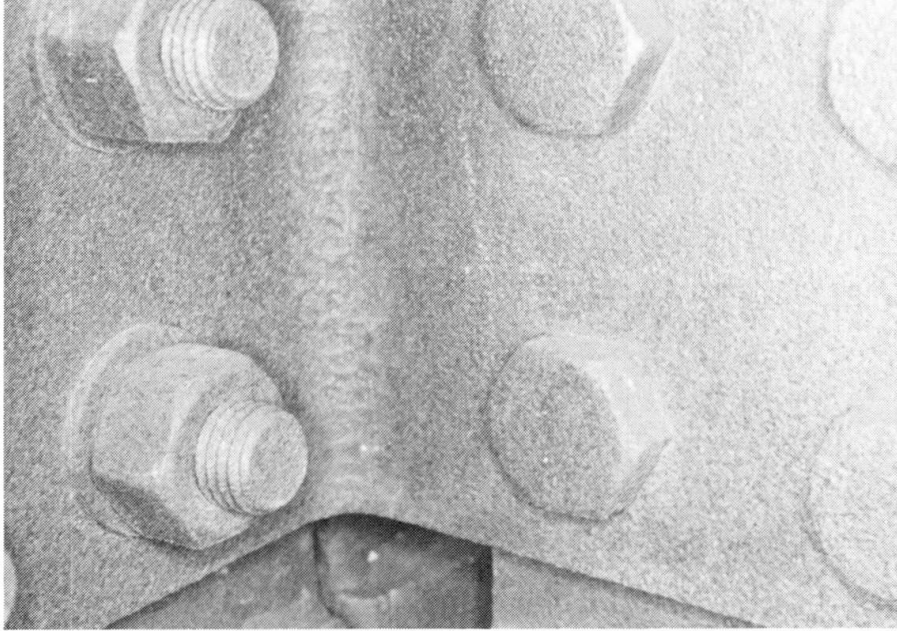

Fig. 7 Fatigue Crack in Longitudinal Girder-Beam (Bent) Angle Connection

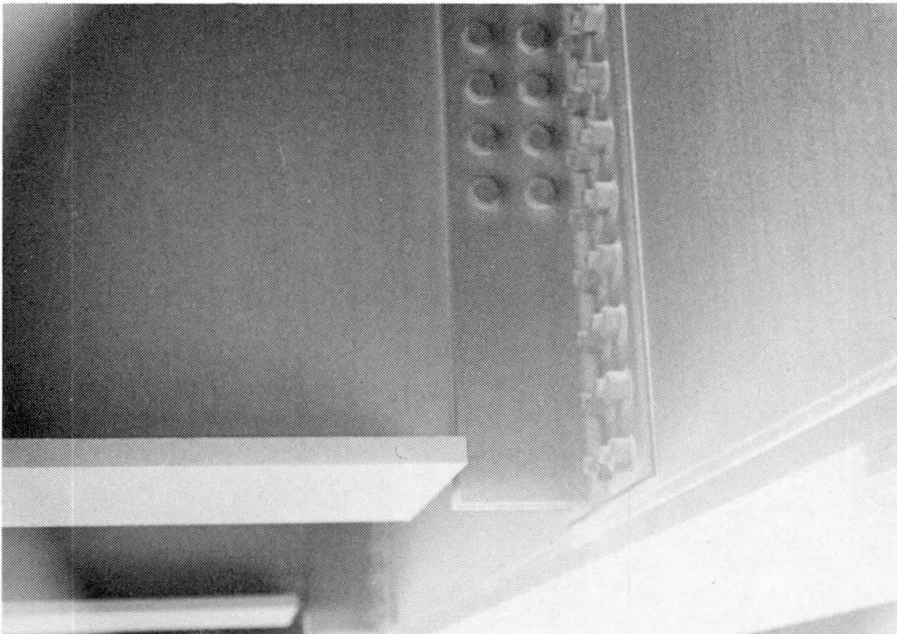

Fig. 8 Longitudinal Girder Not Bolted Full Depth to the Connection Angles

Inspection of the rigid frame bents revealed cracks in the fillet welds at several corner joints where transverse I-beam closure plates were jointed to the bent column flange. Grinding the fillet weld throat in the cracked corner region of the closure plates exposed the crack which had extended into the

groove weld connecting the top flange of transverse beam to the column. Further grinding exposed the crack which extended from the back-up bar halfway through the groove weld thickness. Other bents revealed cracks at the web cope closure plates of the transverse box beam (Fig. 9). Grinding the fillet weld throat into the beam flange exposed cracks extending from the back-up bar into the groove weld thickness.



Fig. 9 Cracks at the Cope Closure Plates of a Box Beam

### 3.2 Probable Causes of Failure

Coping by flame cutting the longitudinal girder and floorbeam webs resulted in high tensile residual stresses along the cut edge as well as at reentrant corner. In addition, coping greatly reduced the section modulus for in-plane bending and left an unstiffened segment of girder web between the flange terminations and the bolt fixity line of the longitudinal girders. At locations where the longitudinal girders were not bolted full depth to the connection angles, the girder web could rotate in plane without developing significant compressive forces in the lower portion of the girder. This resulted in no bottom flange lateral displacement, no web gap distortion, and no fatigue cracking in the web cope or connection angles. In locations where the girder was bolted full depth to the connection angles of the transverse beam, connection restraint resulted in lateral displacement of the bottom flange and web gap distortion from the compressive stresses in the web. Hence, fatigue cracks along the bottom edges of the connection angles were all displacement induced.

Connection geometry at the corner joints of the bent transverse beams produced a fabricated lack-of-fusion defect perpendicular to the primary stress field. Large initial defects and cracks are low fatigue resistant details, and with field measured stress range values exceeding the Category E fatigue limit of 31 MPa, crack growth would be expected. Measured differences in stress range between corners on the same transverse beam flange were observed and attributed to biaxial bending. Biaxial bending resulted from a combination of the vertical loading and longitudinal reaction and braking forces. Current design provisions do not take account of the longitudinal forces when evaluating fatigue resistance in these bent structures.





### 3.3 Recommended Retrofits

Retrofits recommended for fatigue cracking in the longitudinal girders included the drilling of holes to blunt the crack tips. Further retrofit was required to prevent the lateral displacement of the bottom flange and minimize web gap distortion. Otherwise, fatigue crack reinitiation from the retrofit holes and continued crack propagation along the bolt fixity line would result. Several rows of bolts were removed from the girder to transverse beam connection to reduce the compression in the web and help move the flange toward normal alignment. Angles were then bolted to the inside longitudinal girder web and flange and to the connection angle to prevent lateral motion of the bottom flange (Fig. 10) and to provide greater resistance to the end restraint.

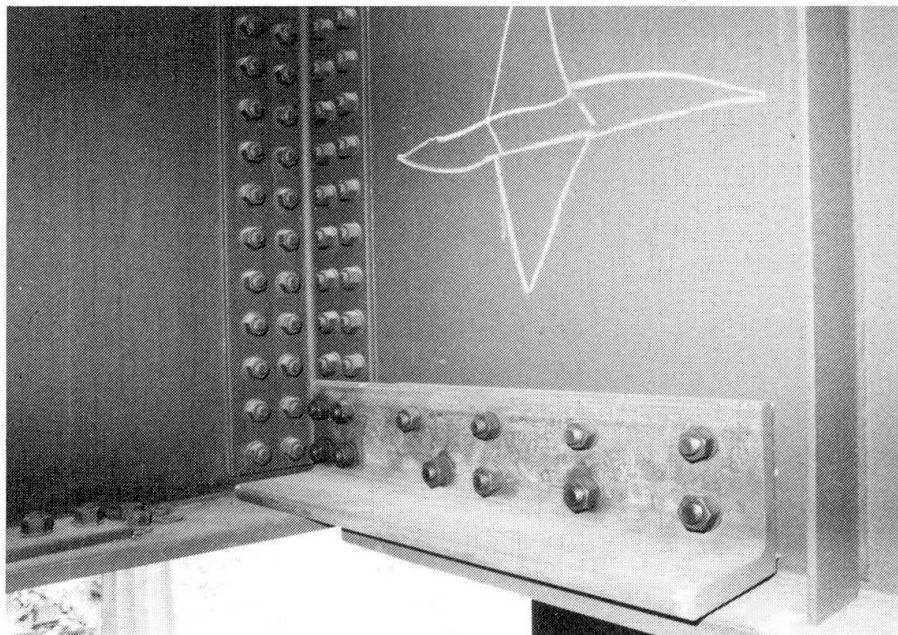

Fig. 10 Retrofit of a Longitudinal Girder Bottom Web Gap

Transfer of the live load forces from the beam top flange to the bent column had to be assured for an effective retrofit of the beam column connection of the bent. Short sections of wide flange shapes were modified by partial removal of the web and were bolted to the top flange of the lower beam and webs of the column (Fig. 11). If the fatigue cracks in the groove welds continued to propagate and eventually led to fracture of the top beam flange to column connection, the live load forces would be transferred via the bolted splice. In addition, the reinforcement provided more resistance to the longitudinal forces.

### 4.0 I-95 OVER THE SUSQUEHANNA RIVER

I-95 crosses the Susquehanna River in Maryland. The structure is a multiple span deck truss bridge whose members are either built-up riveted construction or rolled structural shapes. Transverse floorbeams and longitudinal stringers of the floor system are composite with the reinforced concrete deck. All of the floorbeams are supported by the top chord of the main deck trusses (Fig. 12). Suspended truss spans contain pin and hanger assemblies which consist of riveted box sections [2].

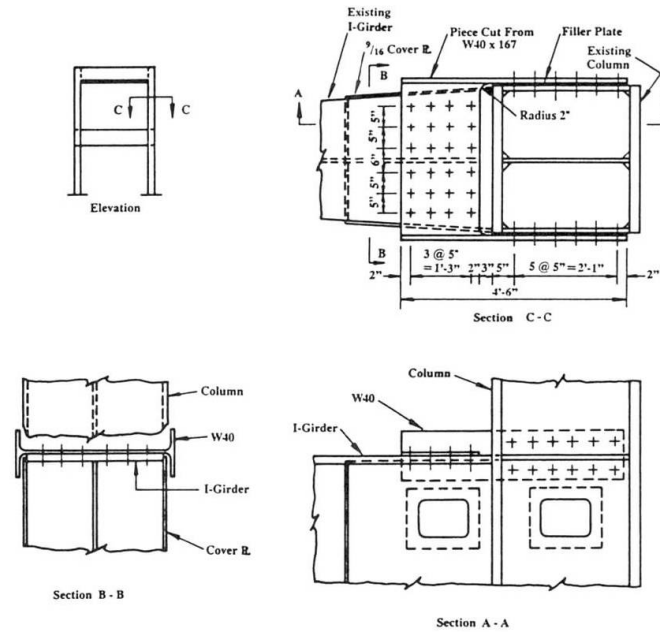

Fig. 11 Retrofit for an I Section Beam Column Connection

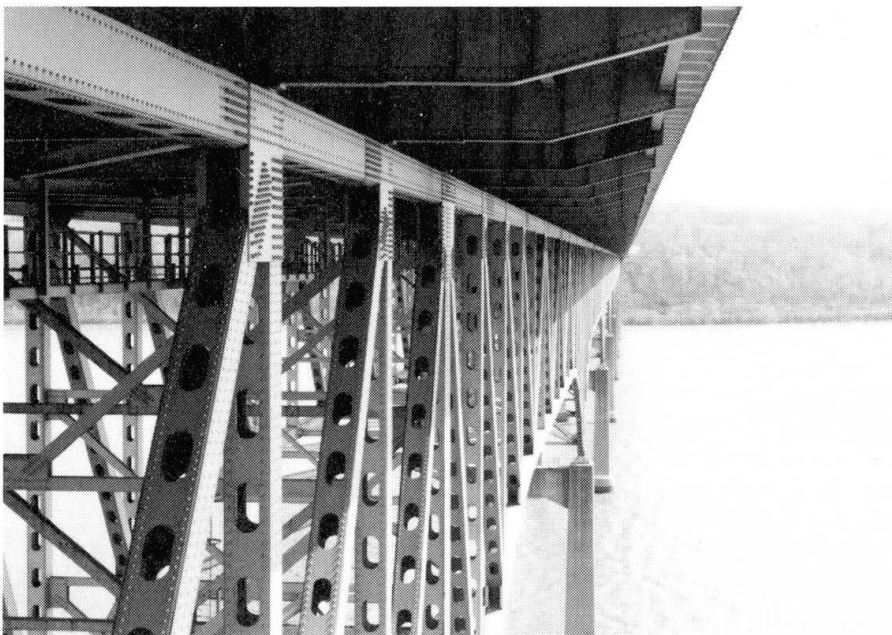

Fig. 12 Truss System of the Susquehanna River Bridge

#### 4.1 Inspection Results and Field Measurements

Inspections of the structure revealed fatigue cracks emanating from the rivet holes in several hanger box sections (Fig. 13). In addition to the fatigue cracks, significant amounts of corrosion product was found between the corner angles and both web and flange plates of the hanger sections (Fig. 13). Environmental corrosion was also found between the gusset and hanger plate as well as on the gusset at the elevation of the pin connection (Fig. 14).

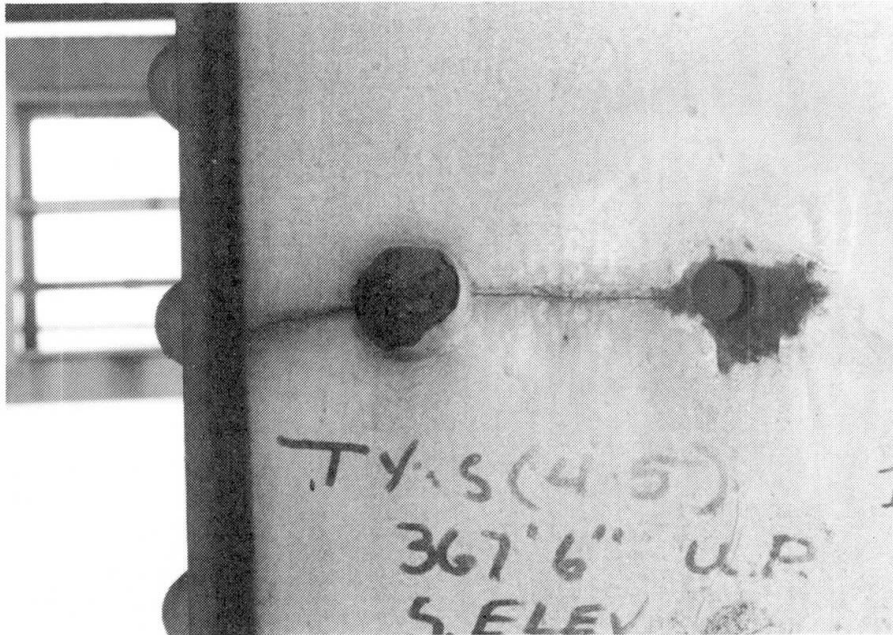

Fig. 13 Corrosion Between a Hanger Flange Plate and Interior Connection Angle and Web Crack from Rivet Hole

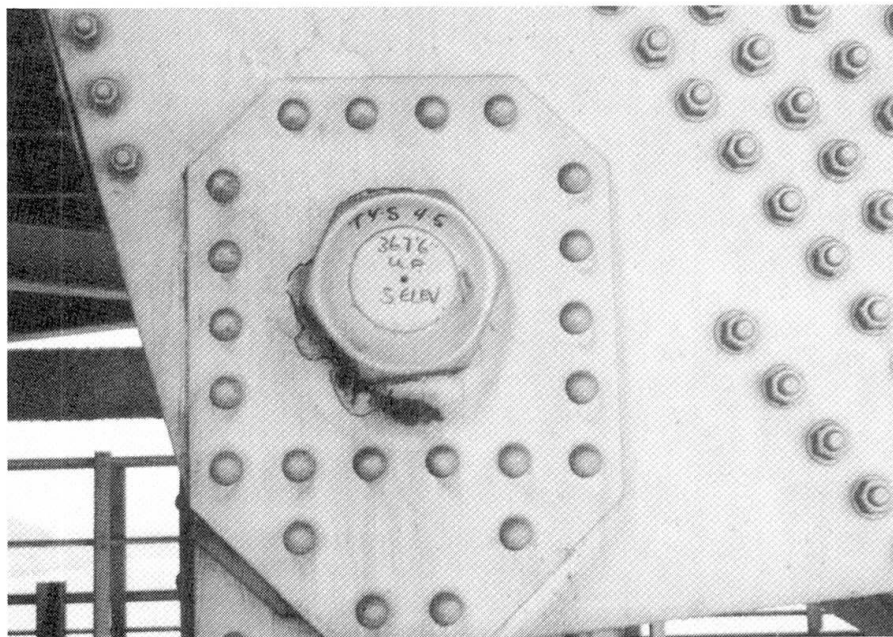

Fig. 14 Corrosion at Upper Pin

Several sets of field measurements were made on the structure between 1985 and 1987. Initial strain measurements were conducted on a single cracked hanger. Under normal traffic, small tension stress cycles developed in all the gages mounted on the hanger, with typical cyclic stress values of 10 MPa. In addition to the small tension cycles, both low level vibration of the hanger, and bending of the hanger web were observed. Unusual large dynamic responses periodically occurred in all gages mounted on the hanger and were on the order of the yield point ( $\sim 250$  MPa).



A subsequent set of field measurements were made after pins of the originally examined hanger were lubricated. For comparison, several other hangers were instrumented. At locations where pins had been lubricated, both the bending of the hanger webs and the large dynamic responses were minimized. Cracked hanger locations with the lubricated assemblies experienced a maximum stress range of 35 MPa. In contrast, unlubricated pin assemblies had hangers which experienced significant axial and bending stresses. Typical values varied up to 76 MPa.

Final field measurements were conducted after all pin assemblies had been lubricated. A maximum stress range of 30 MPa was observed for the original cracked hanger web while a cyclic stress of 55 MPa was recorded for a cracked hanger flange plate in a second location where only one of two pins was lubricated.

#### 4.2 Probable Causes of Failure and Recommended Retrofits

The hanger connections are located directly below open roadway expansion joints which allows salt, water, and debris to fall and collect on the pin and hangers, thereby assisting and accelerating the corrosion process. Field inspections and strain measurements demonstrated that the development of corrosion caused pin restraint which, in turn, led to bending in the hangers. When the bending moment at the hanger joint was high enough to overcome the restraint, sudden release of the pin connection produced the dynamic action. Lubrication of the pins was effective in minimizing hanger bending and dynamic effects by reducing pin restraint and as such, was recommended as a routine maintenance practice. A longer term correction will require the redesign of the pin connection as well as effective control of water and debris by the elimination of open expansion joints.

Cracked hanger plates were temporarily retrofitted by the drilling of holes to blunt the crack tips. For the cracked hanger flange plates, the maximum measured stress range of 55 MPa exceeded the fatigue limit of 48 MPa for riveted members. Fatigue crack propagation is expected to continue in the flange plates. As a result, twice a year inspection of the hangers will be required, until the eventual replacement of the damaged hangers.

#### 5.0 CONCLUSIONS

As replacement costs for highway bridges are often prohibitive, it is desirable to repair and retrofit existing structures to maximize the benefit from limited funds. A majority of fatigue damaged details can be repaired by drilling holes, weld toe peening, or bolting splices over damaged areas to strengthen the connection. In some instances, welding can be used, though care should be exercised so that low fatigue resistant details do not result. Once corrosion is identified as a problem, extensive repairs are often required. Development of corrosion monitors or sensors would greatly assist evaluation and monitoring in difficult to inspect areas of bridges to aid in the inspection and maintenance process.

Examination of the causes of fatigue cracking and corrosion, coupled with implementation of new design tools, code revisions, and effective technology transfer will help to minimize future structural deficiency problems. Simple, realistic models and analysis procedures for member interaction and connection



behavior are needed to reduce the occurrence of distortion induced fatigue problems. Identification of low fatigue resistant details and effective methods for detail classification would ease the burden on designers and limit the incidence of fatigue cracking.

#### REFERENCES

1. FISHER, J. W., *Fatigue and Fracture in Steel Bridges*, Wiley-Interscience, 1984.
2. FISHER, J. W., DEMERS, C., *A Survey of Localized Cracking in Steel Bridges 1981 to 1988*, Lehigh University, ATLSS Report No.89-01, 1989.
3. FISHER, J. W., PENSE, A. W., and YEN, B. T., *Retrofitting Fatigue Cracked Bridge Structures*, International Bridge Conference Proceedings, Pittsburgh, 1983.
4. Personal communication with Dr. Peter Keating, Texas A.& M.
5. FISHER, J. W., HAUSMANN, H., SULLIVAN, M. D., and PENSE, A. W., *Detection and Repair of Fatigue Damage in Welded Highway Bridges*, Transportation Research Board, NCHRP #206, 1979.
6. HAUSMANN, H., FISHER, J. W., and YEN, B. T., *Effect of Peening on Fatigue Life of Welded Details*, ASCE Proceedings, W. H. Munse Symposium on Behavior of Metal Structures - Research to Practice, 1983.
7. FISHER, J. W., BARTHELEMY, B. M., MERTZ, D. R., and EDINGER, J. A., *Fatigue Behavior of Full Scale Welded Bridge Attachments*, Transportation Research Board, NCHRP #227, 1980.
8. FISHER, J. W., and MERTZ, D. R., *Hundreds of Bridges - Thousands of Cracks*, ASCE - Civil Engineering, Vol. 5, No. 4, 1985.