

# Properties of brace encased in concrete-filled steel tube

Autor(en): **Waka, Akira / Iwata, Mamoru / Watanabe, A.**

Objektyp: **Article**

Zeitschrift: **IABSE reports = Rapports AIPC = IVBH Berichte**

Band (Jahr): **60 (1990)**

PDF erstellt am: **23.07.2024**

Persistenter Link: <https://doi.org/10.5169/seals-46530>

## **Nutzungsbedingungen**

Die ETH-Bibliothek ist Anbieterin der digitalisierten Zeitschriften. Sie besitzt keine Urheberrechte an den Inhalten der Zeitschriften. Die Rechte liegen in der Regel bei den Herausgebern.

Die auf der Plattform e-periodica veröffentlichten Dokumente stehen für nicht-kommerzielle Zwecke in Lehre und Forschung sowie für die private Nutzung frei zur Verfügung. Einzelne Dateien oder Ausdrucke aus diesem Angebot können zusammen mit diesen Nutzungsbedingungen und den korrekten Herkunftsbezeichnungen weitergegeben werden.

Das Veröffentlichen von Bildern in Print- und Online-Publikationen ist nur mit vorheriger Genehmigung der Rechteinhaber erlaubt. Die systematische Speicherung von Teilen des elektronischen Angebots auf anderen Servern bedarf ebenfalls des schriftlichen Einverständnisses der Rechteinhaber.

## **Haftungsausschluss**

Alle Angaben erfolgen ohne Gewähr für Vollständigkeit oder Richtigkeit. Es wird keine Haftung übernommen für Schäden durch die Verwendung von Informationen aus diesem Online-Angebot oder durch das Fehlen von Informationen. Dies gilt auch für Inhalte Dritter, die über dieses Angebot zugänglich sind.

# Properties of Brace Encased in Concrete-Filled Steel Tube

Propriétés d'une entretoise de contreventement encastrée  
dans un profil tubulaire rempli de béton

Eigenschaften betonumhüllter Fachwerkdiagonalen

**Akira WADA**

Professor  
Tokyo Inst.  
Tokyo, Japan

**Mamoru IWATA**

Doctor of Eng.  
Nippon Steel Corp.  
Tokyo, Japan

**A. WATANABE**

Structural Eng.  
Nippon Steel Corp.  
Tokyo, Japan

**H. KURIBAYASHI**

Structural Eng.  
NTT Corp.  
Tokyo, Japan

## 1. PREFACE

Steel has high strength and deformation resistance (see Fig. 1). Braces are extremely effective in increasing the horizontal stiffness and strength of steel frame structures. But braces buckle and rapidly lose strength when subjected to compression force (see Fig. 2). This makes it difficult in plastic design depending on stable plasticity and braces cannot be expected to absorb energy.

Therefore, particularly in earthquake-prone countries, designs of structure are considerably limited when braces are adopted for high-rise buildings.

The authors considered that, if brace buckling could be prevented and the energy absorption capacity increased, damage by earthquakes to columns and beams which support permanent loads would be reduced. The authors developed a bracing system having stable restoration property (see Fig. 3) and in which buckling was prevented by using core plate encased in concrete-filled steel tubes. This paper reports on an experiment conducted on a scale model to study the application of such braces to an actual 24-storied building.

## 2. EXPERIMENT

### 2.1 Experiment models

As shown in Fig. 4, the experiment models are 1/2.5 scale and consist of braces, columns and beams. Model A has braces whose core steel yield point is  $260.7 \text{ N/mm}^2$ , and model B  $477.3 \text{ N/mm}^2$ , while model C has no braces. Figure 5 shows the cross section of the brace used in Models A and B. Core steel is bound by mortar and steel tube to prevent buckling. The coating material isolates the core plate from mortar to prevent an axial force from traveling from core steel to mortar and steel tube.

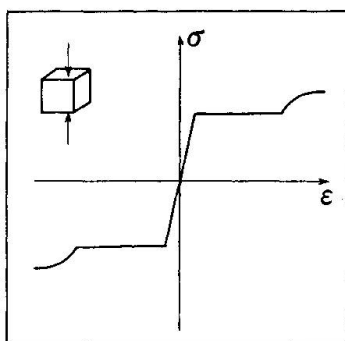

Fig. 1

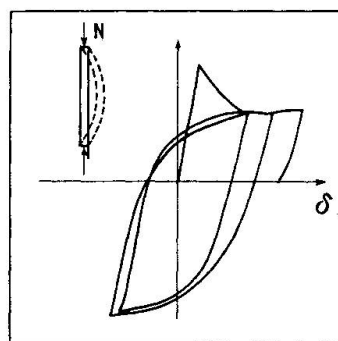

Fig. 2

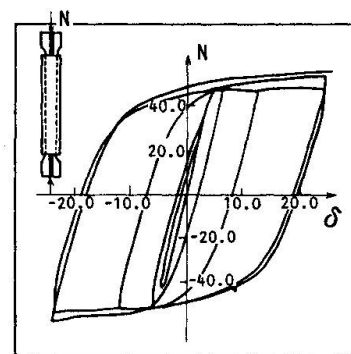

Fig. 3



2.2 Experiment methods

To simulate the behavior of an actual structure under a horizontal force, horizontal rollers were attached to the underside of the columns. And to bear the horizontal force, a vertical roller was attached to the center of the lower beam (see Fig. 4). The horizontal force was applied to the column tops, the direction of application being alternated from left to right. Measurements were made regarding relative storey deformation, axial deformation, strain of braces, etc.

2.3 Results of experiment

All models were confirmed to possess stable restoration property up to a relative storey deformation angle of 1/100. And braces did not buckle under compressive forces. Figure 7 shows the hysteresis curve of Model A and envelop curves of Models B and C. Models A and B show that the bracing system markedly increases the horizontal stiffness and strength of frame keeping deformation capacity.

3. CONCLUSION

The above results confirm that frames with high energy absorption and earthquake resistance can be made by incorporating braces whose buckling is prevented by concrete-filled steel tube. The authors are confident that by adjusting the cross-sectional area and yield point of the brace core steel, the strength and stiffness of structures can be freely designed.

REFERENCE

1. M. FUJIMOTO, A. WADA, E. SAEKI, Y. HITOMI, A. WATANABE : Properties of Brace Encased in Buckling-Restraining Concrete and Steel Tube, Ninth World Conference on Earthquake Engineering, August 1988, Tokyo-Kyoto, Vol. IV, pp. 719-723.

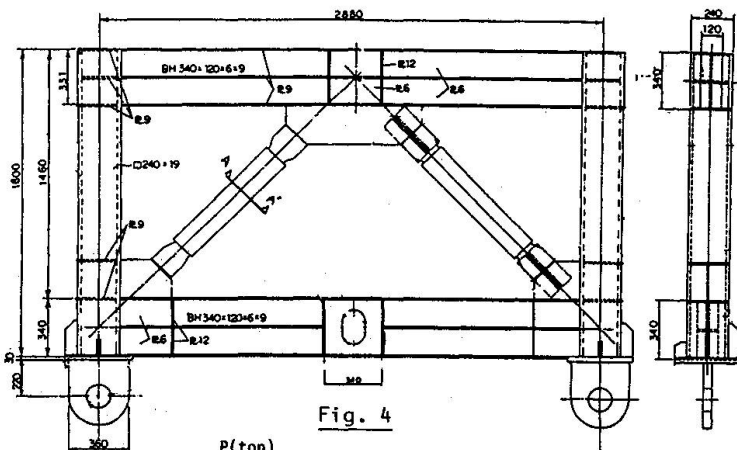

Fig. 4

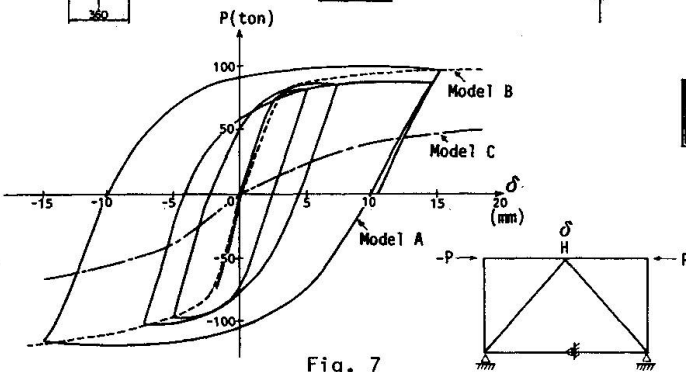
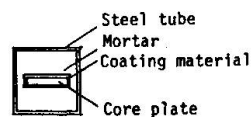

Fig. 7

Table 1 List of Experiment Models

Name	Core Plate			Steel Tube
	Cross-sectional Area (cm <sup>2</sup> )	Yield Stress (N/mm <sup>2</sup> )	Yield Load (kN)	
Model A	24.64	260.7	642.3	□-150x150x4.5
Model B	14.44	477.3	689.2	□-150x150x4.5
Model C	-	-	-	-



Section A-A

Fig. 5

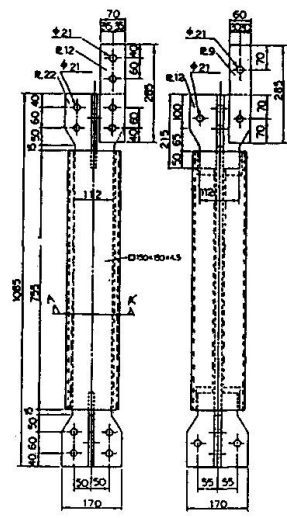

Model A

Fig. 6