

Controlled test for composite slab design parameters

Autor(en): **Patrick, Mark / Poh, K. Weng**

Objektyp: **Article**

Zeitschrift: **IABSE reports = Rapports AIPC = IVBH Berichte**

Band (Jahr): **60 (1990)**

PDF erstellt am: **23.07.2024**

Persistenter Link: <https://doi.org/10.5169/seals-46467>

Nutzungsbedingungen

Die ETH-Bibliothek ist Anbieterin der digitalisierten Zeitschriften. Sie besitzt keine Urheberrechte an den Inhalten der Zeitschriften. Die Rechte liegen in der Regel bei den Herausgebern.

Die auf der Plattform e-periodica veröffentlichten Dokumente stehen für nicht-kommerzielle Zwecke in Lehre und Forschung sowie für die private Nutzung frei zur Verfügung. Einzelne Dateien oder Ausdrucke aus diesem Angebot können zusammen mit diesen Nutzungsbedingungen und den korrekten Herkunftsbezeichnungen weitergegeben werden.

Das Veröffentlichen von Bildern in Print- und Online-Publikationen ist nur mit vorheriger Genehmigung der Rechteinhaber erlaubt. Die systematische Speicherung von Teilen des elektronischen Angebots auf anderen Servern bedarf ebenfalls des schriftlichen Einverständnisses der Rechteinhaber.

Haftungsausschluss

Alle Angaben erfolgen ohne Gewähr für Vollständigkeit oder Richtigkeit. Es wird keine Haftung übernommen für Schäden durch die Verwendung von Informationen aus diesem Online-Angebot oder durch das Fehlen von Informationen. Dies gilt auch für Inhalte Dritter, die über dieses Angebot zugänglich sind.

Controlled Test for Composite Slab Design Parameters

Essai contrôlé pour paramètres de calcul de dalles mixtes

Gezielter Test für Verbundplattenbemessungsparameter

Mark PATRICK

Princ. Res. Officer
BHP Melbourne Res. Lab.
Mulgrave, Australia

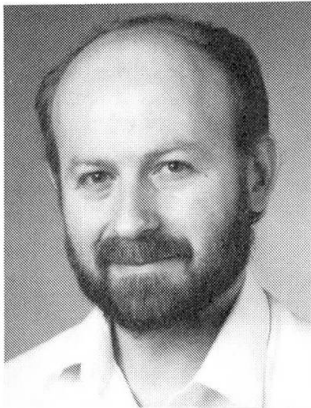

Mark Patrick, born 1952, obtained his Master's degree in civil engineering at Melbourne Univ. and is currently undertaking a Ph.D. degree at Sydney Univ. His main research interests concern the behaviour of composite beams and slabs in buildings. He is Chairman of the Standards Australia Composite Slab Subcommittee.

K. Weng POH

Prof. Scientist
BHP Melbourne Res. Lab.
Mulgrave, Australia

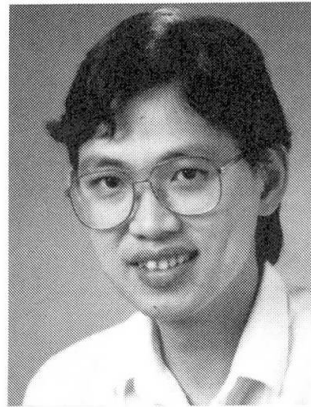

Weng Poh, born 1961, obtained his undergraduate degree in civil engineering at Melbourne University. He is currently completing a Master's degree at Monash University on a part-time basis. His research interests include analytical modelling of composite beams and slabs.

SUMMARY

The details of a controlled tests are reported whereby a small element of a composite slab is used to simulate the conditions during longitudinal slip failure. Called the "slip block test", the shear connection performance of a profile can be determined. After breaking adhesion bond, the clamping force is varied while continuously measuring the longitudinal slip resistance to determine the values of the profile rib resistance and the coefficient of friction. These parameters can be used directly in a partial shear connection model to predict the strength of composite slabs. The test may be included in a future Australian Standard.

RÉSUMÉ

Un essai effectué sous conditions de contrôle ciblé est décrit ci-après dans lequel un élément de dalle mixte est utilisé pour simuler les conditions de rupture par glissement longitudinal. Par ce test qui s'appelle le «slip block test» il est possible de déterminer l'efficacité du joint de cisaillement d'un profil. Après rupture d'adhérence, on fait varier la force de serrage tout en mesurant la résistance au glissement longitudinal, ceci pour déterminer les valeurs de résistance des nervures du profil ainsi que le coefficient de frottement. Ces paramètres peuvent être directement utilisées dans un modèle de joint partiel de cisaillement en vue d'estimer la résistance de dalles mixtes. Il est possible que ce test soit inclus dans une future norme australienne.

ZUSAMMENFASSUNG

Es wird über die Einzelheiten eines gezielten Tests berichtet, in welchem ein kleines Element einer Verbundplatte dazu benutzt wird, die Verhältnisse während des Versagens durch Längsverschiebung, zu simulieren. Der Test wird „Slip Block Test“ genannt und ermöglicht die Ermittlung der Wirkung des Schubverhaltens im Verbund eines Querschnitts. Nach dem Brechen der Haftverbindung wird die Klemmkraft während andauernder Längsschlupfwiderstandsmessungen variiert, um die Widerstandswerte der Profilrippen und den Reibungskoeffizienten zu ermitteln. Diese Parameter können unmittelbar für die Berechnung der Festigkeit der Verbundplatte in einem Teil-Schub-Modell benutzt werden. Es ist möglich, dass dieser Test in einem zukünftigen australischen Standard aufgenommen wird.



1. INTRODUCTION

Researchers have developed a number of different small-scale tests to gain information about the shear connection performance of profiled steel sheetings in composite slabs [e.g. 1,2,3,4]. In certain cases this has been done for comparison purposes only [1]. However, with varying degrees of success this information has also been used to determine parameters for physical models to predict the strength of simply-supported composite slabs [2,3,4].

Current design codes and specifications almost universally use the empirical shear-bond model to predict the strength of these members [e.g. 5]. This approach requires all of the information regarding the shear connection performance to come from full-scale slab tests. The tests must cover the full range of the design parameters and this may require a substantial number of slabs to be tested.

A series of well-controlled tests has been conducted on simply-supported composite slabs (using a profile designated herein as "A") which exhibited strong slip-flexure behaviour with end slip occurring prior to ultimate load; otherwise failure occurred by flexure [6]. The shear-bond method could not account for the variations of the test results, particularly when loading pattern was changed. A similar problem had already been experienced applying the method to the results of another profile (profile "B") which failed at first end slip. Therefore, during the course of both test programs it was decided to develop a small-scale test to investigate the physical processes governing the longitudinal slip failures, and to determine whether appropriate parameters could be used in physical models to predict the strengths of the slabs tested. This paper reports on the details of the small-scale test developed.

2. INITIAL DEVELOPMENT OF TEST

2.1 Mechanical Interlock and Frictional Resistance

The longitudinal slip resistance of a profile depends on a complex interaction between the steel sheeting and the surrounding concrete. Adhesion bond between the sheeting and concrete initially plays a part in this behaviour [7]. Following the breakdown of adhesion bond, slip is resisted by mechanical interlock and friction developed between the two materials. Profile shape is known to affect the mechanical interlock which may be enhanced by embossments or other types of shear connector devices. Clamping forces which develop transverse to the slip interface, particularly where the vertical loads are transmitted through the sheeting at the supports, give rise to frictional resistance.

The various small-scale tests developed to date have been used to directly measure the longitudinal slip resistance of profiles. Concrete has been cast against pieces of the sheeting to be tested with the profile ribs aligned in the direction of thrust. The tests have been performed such that the clamping forces developed in the transverse direction have either remained unknown or have been held constant throughout each test. Therefore, once slip has occurred only the combined resistance of mechanical interlock and friction due to the presence of clamping forces has been measured.

An initial investigation was made to see whether the separate components of longitudinal slip resistance, namely adhesion bond, mechanical interlock and frictional resistance, could be identified and possibly measured by performing a small-scale test in a carefully controlled manner.

2.2 Trial Slip Block Tests

A small block which represented an element of a composite slab with profile B was constructed by cutting two adjacent pans of the profile longitudinally along their centres leaving a single ribbed piece of sheeting. It was then cut to a length of 300 mm and since the profile rib spacing, b_r , was 300 mm, the shape in plan was square. A matching flat steel base plate 10 mm thick was cut and the piece of sheeting was positioned on it with the rib centrally aligned. It was attached with spot welds through the pans. Finally, a formwork box was built to support the base plate, and the specimen was cast horizontally with a light piece of welded wire fabric placed in the cover slab which was 35 mm thick.

At a suitable age the block was stripped and the base plate fixed to the solid base of a servo-controlled testing machine. A heavy-duty roller bearing assemblage was bedded onto the top of the block and a constant vertical load V was applied through it with the testing machine in load control. Using a separate jacking system operating in position control, a horizontal force H was gradually applied to an end of the block in the direction of the sheeting rib. Slip between the sheeting and concrete was measured using displacement transducers positioned at the face opposite where the horizontal load was applied. The roller bearing was orientated such as to allow the block to slide in the direction of the sheeting rib without interference from the testing machine. The test set-up is shown schematically in Fig. 1.

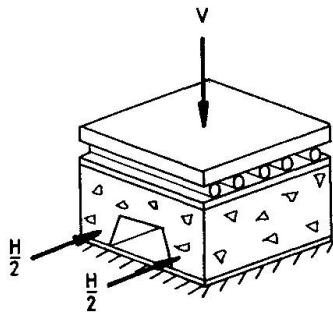
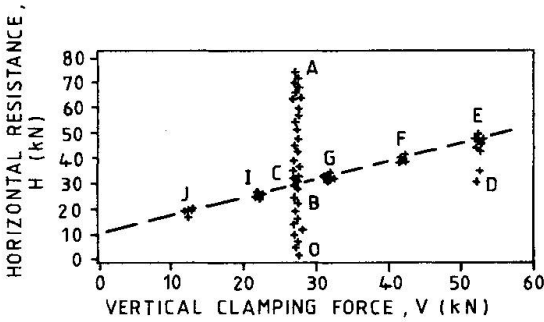

Fig. 1 Schematic Representation of Slip Block Test Set-up

The first stage of the loading sequence was performed under constant vertical load V and is identified by points O, A, B and C in Fig. 2. The horizontal force was applied until at point A adhesion bond suddenly broke and the block dynamically slipped to point B. The initial value chosen for V was sufficient to prevent over-turning of the block prior to reaching point A. The block had come to equilibrium again at point B; the resulting horizontal force acting was affected by the stiffness of the horizontal loading system and was not the limiting value of longitudinal slip resistance. By inducing further slip H rose steadily until it reached a relatively constant value at point C. For the next stage, V was increased without adjusting H (see point D in Fig. 2(a)). Further slip was induced and H increased to a new constant value at point E. This process was repeated except that V was successively reduced rather than increased, and values of H were measured for points F, G, I and J shown in Fig. 2.

Fig. 2 Trial Slip Block Test Performed on Profile B



(a) H-V Curve

It can be observed from Fig. 2(a) that points C, E, F, G, I and J all lie close to a linear line shown dashed, the "friction line". The slope of the line equals the coefficient of friction between the sheeting and concrete, μ . By extrapolating the line to intercept the vertical axis, the contribution to slip resistance offered by the mechanical interlock of the profile is determined. Therefore, when a clamping force V acts on the block once slip has been induced, the horizontal resistance to slip, H , can be written as:

$$H = b_1 H_{rib} + \mu V \quad (1)$$

where H_{rib} = rib resistance per unit length due to mechanical interlock; and b_1 = length of slip block.

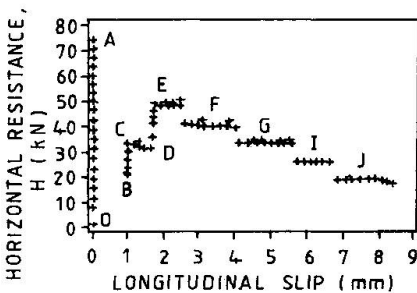

(b) H-Slip Curve

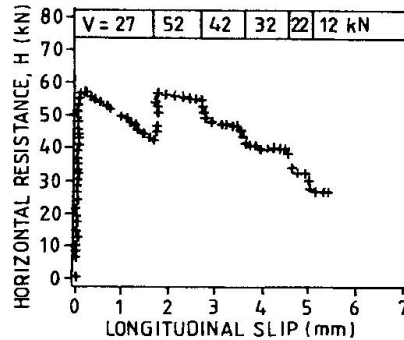

Fig. 3 Trial Slip Block Test Performed on Profile A Showing H-Slip Curve



When the same test procedure was applied to profile A it was observed that slip began progressively rather than suddenly and that the horizontal resistance, H , did not stabilize under constant clamping force V until large slip had occurred. A typical H -Slip curve is shown in Fig. 3 where it can be seen that for slips less than 5 mm, on attaining the maximum value of H for each value of V , H declined as slip progressed. This behaviour is consistent with mechanical interlock degrading with slip, and the friction line varies with the amount of slip.

3. DISCUSSION

3.1 Profiles with Weak Mechanical Interlock

For profiles which exhibit weak mechanical interlock such as profile B, adhesion bond strength, which is particularly influenced by the condition and type of sheeting coating, can have a significant influence on slab strength [7]. The breakdown of adhesion bond is initiated where the first flexural crack occurs, and the tensile force in the sheeting increases much more rapidly with increasing curvature after this stage. The flexural tensile strength of the concrete and the loading arrangement therefore have a significant effect on determining the failure load.

These slabs can exhibit brittle collapse at the onset of end slip, and the dynamic transition between points A and B in Fig. 2(b) is indicative of this behaviour. The slip block test can therefore identify this undesirable feature of a profile. While the value of H at point A in Fig. 2 is a measure of the adhesion strength, it can, however, be affected by the magnitude of the co-existing clamping force. It can also vary significantly even when seemingly identical specimens are tested in the same manner, which is reflected in slab tests too. Use of this information to develop a physical model to predict the maximum strength of these slabs is being investigated, and the findings will be reported elsewhere after a set of slabs using profile B has been tested with companion slip blocks.

3.2 Repeated Measurement of Rib Resistance and Friction Coefficient

Because rib resistance and the coefficient of friction can vary with slip, a procedure for repeatedly measuring these parameters has been developed and a family of friction lines can be generated. This improved procedure was applied to a specimen with profile A and is described with reference to Fig. 4.

Fig. 4 Improved Slip Block Test Performed on Profile A

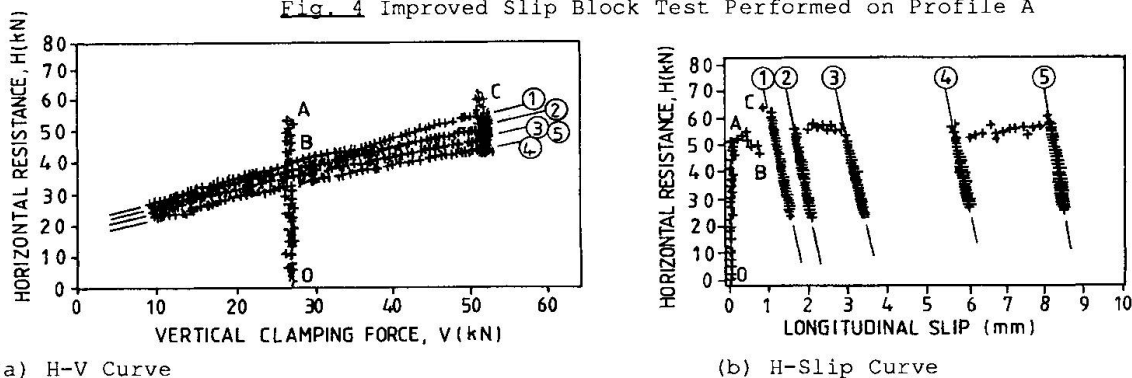

(a) H-V Curve

(b) H-Slip Curve

Immediately slip is detected, the clamping force, V , is increased to some chosen maximum value. (Note in Fig. 4(b) this was done somewhat belatedly at point B after almost a full 1 mm of slip.) The horizontal load, H , is increased until slip begins again. At this stage the test is interrupted with the block held stationary (point C in Fig. 4). Next V is reduced at a slow constant rate without adjusting the horizontal jacking system which is acting in position control. Slip is induced since the block cannot support the horizontal load. The values of V , H and slip are continuously recorded. The vertical load is reduced until the block just begins to overturn which is detected by the front of the block lifting, and the first cycle of the test is completed. The first friction line is thus established (line 1 in Fig. 4(a)), and values of H_{rib} and μ can be determined which correspond to the mean value of slip over the slip increment. The corresponding H-Slip curve is shown in Fig. 4(b). The slope of this line and therefore the increment of slip

incurred while V was reduced is dependent on the stiffness of the horizontal loading system. This process can be repeated at different values of slip (see lines 2 to 5 in Fig. 4) thus establishing the variation of H_{rib} and μ with slip.

3.3 Standardization of Block Size

Recently the slip block test has been used to determine the shear connection performance of a wide range of profile types from various countries. A standard width of 350 mm has been found suitable when testing these products although this dimension does not necessarily match the rib spacing. For profiles with closely spaced ribs, two ribs may be included in the specimen, as may any other unusual features which might affect the slip resistance. The effective width of the slip block, b_r , applicable to each feature can be assessed for each situation. A standard length of 300 mm has been adopted except when length effects are to be investigated. A minimum cover slab thickness of 35 mm is recommended.

4. CONCLUSIONS

The slip block test is quick, simple and economical to apply, and can yield essential information about the shear connection performance of profiles with very different characteristics. Adhesion bond, mechanical interlock and friction can collectively contribute toward the total longitudinal slip resistance of a profile and can be separately identified using the test. In particular, parameter values determined from the test can be used directly in a physical model using partial shear connection theory which accurately predicts the strengths of slabs [6]. The test can therefore complement a test program involving full-scale slab testing.

NOTATION

- b_l = length of slip block.
 b_r = effective width of slip block, usually equal to the profile rib spacing.
 H = horizontal resistance to slip measured in slip block test.
 H_{rib} = rib resistance per unit length in absence of clamping force determined from slip block test.
 V = clamping force in slip block test.
 μ = coefficient of friction between sheeting and concrete determined from slip block test.

REFERENCES

1. JOLLY, C.K. and ZUBAIR, A.K.M., The Efficiency of Shear-Bond Interlock Between Profiled Steel Sheeting and Concrete, Composite Steel Structures - Advances, Design and Construction, Elsevier Applied Science, 1987.
2. STARK, J., Design of Composite Floors with Profiled Steel Sheet, Fourth International Specialty Conference on Cold-Formed Steel Structures, St. Louis, Missouri, U.S.A., 1976, pp. 893-922.
3. DANIELS, B.J., Shear Bond Pull-Out Tests for Cold-Formed-Steel Composite Slabs, Publication ICOM 194, Ecole Polytechnique Federale de Lausanne, June, 1988.
4. BODE, H., KUNZEL, R. and SCHANZENBACH, J., Profiled Steel Sheeting and Composite Action, Ninth International Specialty Conference on Cold-Formed Steel Structures, St. Louis, Missouri, U.S.A., 1988, pp. 343-359.
5. COMMISSION OF THE EUROPEAN COMMUNITIES, Draft Eurocode No. 4: Common Unified Rules for Composite Steel and Concrete Structures, Luxembourg, 1985.
6. PATRICK, M. and BRIDGE, R.Q., Parameters Affecting the Design and Behaviour of Composite Slabs, IABSE Symposium on Mixed Structures Including New Materials, Brussels, Belgium, September 5-7, 1990.
7. PATRICK, M., Design of Continuous Composite Slabs - The Issue of Ductility, Steel Construction Journal, Australian Institute of Steel Construction, Vol. 23, No. 3, August, 1989, pp. 2-10.

Leere Seite
Blank page
Page vide