

# The twin cable-stayed composite bridge at Baytown, Texas

Autor(en): **Svensson, Holger S. / Lovett, Thomas G.**

Objektyp: **Article**

Zeitschrift: **IABSE reports = Rapports AIPC = IVBH Berichte**

Band (Jahr): **60 (1990)**

PDF erstellt am: **23.07.2024**

Persistenter Link: <https://doi.org/10.5169/seals-46499>

## **Nutzungsbedingungen**

Die ETH-Bibliothek ist Anbieterin der digitalisierten Zeitschriften. Sie besitzt keine Urheberrechte an den Inhalten der Zeitschriften. Die Rechte liegen in der Regel bei den Herausgebern.

Die auf der Plattform e-periodica veröffentlichten Dokumente stehen für nicht-kommerzielle Zwecke in Lehre und Forschung sowie für die private Nutzung frei zur Verfügung. Einzelne Dateien oder Ausdrucke aus diesem Angebot können zusammen mit diesen Nutzungsbedingungen und den korrekten Herkunftsbezeichnungen weitergegeben werden.

Das Veröffentlichen von Bildern in Print- und Online-Publikationen ist nur mit vorheriger Genehmigung der Rechteinhaber erlaubt. Die systematische Speicherung von Teilen des elektronischen Angebots auf anderen Servern bedarf ebenfalls des schriftlichen Einverständnisses der Rechteinhaber.

## **Haftungsausschluss**

Alle Angaben erfolgen ohne Gewähr für Vollständigkeit oder Richtigkeit. Es wird keine Haftung übernommen für Schäden durch die Verwendung von Informationen aus diesem Online-Angebot oder durch das Fehlen von Informationen. Dies gilt auch für Inhalte Dritter, die über dieses Angebot zugänglich sind.

## The Twin Cable-Stayed Composite Bridge at Baytown, Texas

Pont jumelé mixte à haubans de Baytown au Texas

Schräggabelbrücke mit Verbundträgern in Baytown, Texas

### H. S. SVENSSON

Manager  
Leonhardt, Andrä & Partner  
Stuttgart, FR Germany



Holger S. Svensson, born in 1945, received his Dipl.-Ing. (M.Sc.) from Stuttgart University in 1969, his US registration as professional engineer (P.E.) in 1985, and his Canadian registration (P.Eng.) in 1988. He has extensive experience in the design of long-span, cable-stayed bridges all over the world.

### Thomas G. LOVETT

Assoc. Vice Pres.  
Greiner, Inc.  
Tampa, FL, USA



Thomas G. Lovett, born in 1953, received his Bachelor of Science degree in Civil Engineering from the University of Maryland in 1975 and is a U.S. registered professional engineer (P.E.). He has participated in the design of several long span cable stayed bridges in the United States.

### SUMMARY

This cable-stayed bridge with a main span of 381 m has two independent composite beams. The twin diamond shaped concrete towers rise about 130 metres above ground. Each beam comprises a steel grid from exterior main girders and cross-girders with a concrete roadway slab on top which was designed for composite action under dead and live load. The stay cables consist of strands within a poly-ethylene pipe and cement grout.

### RÉSUMÉ

Ce pont haubané, d'une portée centrale de 381 m, présente deux tabliers indépendants à construction mixte. Chaque tablier est composé de poutres principales en treillis métallique reliées par des entretoises métalliques et surmontées d'une dalle en béton servant de chaussée; l'ensemble agissant comme construction mixte pour le poids propre et pour les surcharges. Les pylônes jumelés sont formés d'un Y renversé et atteignent une hauteur de 130 m. Les haubans sont composés de torons parallèles entourés d'une gaine en polyéthylène et protégés d'un coulis de ciment.

### ZUSAMMENFASSUNG

Diese Schräggabelbrücke mit einer Hauptspannweite von 381 m besitzt zwei Verbundträger, die aus einem Stahlträgerrost und Querträgern bestehen. Die Betonfahrbahnplatte wurde für Verbundwirkung unter ständigen Lasten und Verkehrslast bemessen. Die rhombusförmigen Doppelpylone erreichen 130 m Höhe. Die parallelen Litzen der Schräggabel werden durch Polyäthylen-Rohren mit Zementinjektion geschützt.



## 1 INTRODUCTION

The bridge crosses the Houston Ship Channel 20 miles east of Houston between the cities Baytown and LaPorte in the State of Texas, USA, where it replaces the severely restrictive two-lane Baytown tunnel by an eight-lane high level crossing. It is the first cable-stayed bridge with two superstructures, and its total deck area of about 32 800 m<sup>2</sup> makes it one of the largest cable-stayed bridges to date.

In accordance with current US requirements alternate steel and concrete designs were prepared. In 1987 four bids ranging from 91.3 to 126.5 million dollars were received for the total project including the approach bridges, with all bidders selecting the steel-composite main bridge.

Construction started in 1987, and the bridge will be opened in 1991.

## 2 OVERALL SYSTEM

The cable-stayed bridge is continuous over its length of 675 m, see Fig. 1. The beam is supported by stay cables in a semi-fan arrangement at about 15 m intervals.

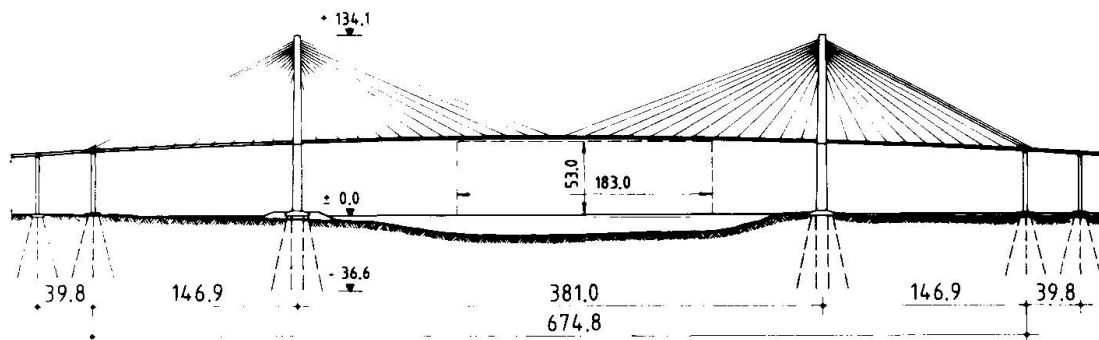

Fig. 1 General Layout

The support conditions render a completely symmetric structure. The beams are connected to each tower with flexible neoprene bearings, 250 mm high, which follow the temperature movements by shear deformation and distribute longitudinal forces equally to both towers. The anchorpiers are connected to the beams by rotational bearings. They are slender enough to follow the temperature movements of the beam by deflection. The vertical beam rotations are taken by strip seals above the anchor piers, the longitudinal movements are accommodated by expansion joints above the next piers. Transverse wind loads are taken by bumpers at the towers, and at the anchor piers.

The bridge is located in a hurricane prone area near the Gulf of Mexico. The basic design wind speed for a 100 year return period was determined as 50 m/sec at 10 m height with a duration of 10 minutes. Wind tunnel tests were performed on a section model (scale 1:96, [1]) and a full bridge model (scale 1:250, [2]). The test results and an independent analytical investigation showed that the bridge is aerodynamically stable for laminar wind with a speed in excess of 67 m/sec. For a turbulence intensity of 12% the peak-to-peak deflection at mid-span comes to 1.65 m.

The structural design was done in accordance with the AASHTO Bridge Specification, amended as required by other US and international codes.

### 3 COMPOSITE BEAM

#### 3.1 Structural Details

The four lanes with full shoulders require a roadway width of 22 m for each direction of travel. Two, three and four cable planes for supporting the roadway transversely were investigated. It was found that two independent beams - each supported by two outer cable planes, see Fig. 6, - are most economic. The cross-section of an individual beam is shown in Fig. 2. It consists of a steel grid composite with a concrete roadway slab.

The outside main girders have one continuous longitudinal stiffener, see Fig. 3. The vertical stiffeners at 5.2 m intervals are welded to the main girders, except for the regions of high moments near the center and the ends of the bridge where they are bolted to the bottom flanges due to fatigue. All floor beams are field bolted to the vertical stiffeners, see Figs. 2 and 3.

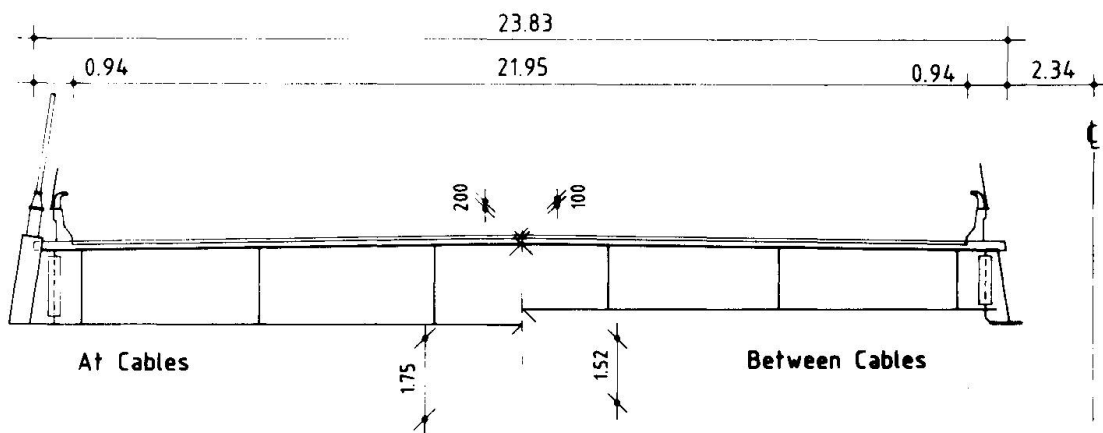

Fig. 2 Individual Beam Cross-Section

The concrete deck is 200 mm thick and has a 100 mm reinforced concrete wearing surface. Longitudinal and transverse composite action is achieved by conventional shear studs. On the main girder top flange they are arranged in rows of three with a constant longitudinal spacing of 115 mm.

Crack control is achieved by a substantial amount of reinforcement with close spacing. At midspan where the compression is smallest diam. 18 mm bars at 115 mm spacing top and bottom (2,2%) were used longitudinally and transversely.

The cables are anchored in welded boxes bolted to the main girders, see Fig. 4. The eccentricity moment is carried by a force couple in compression to the roadway slab and in tension to the bottom flange of the full-depth main floor beams.

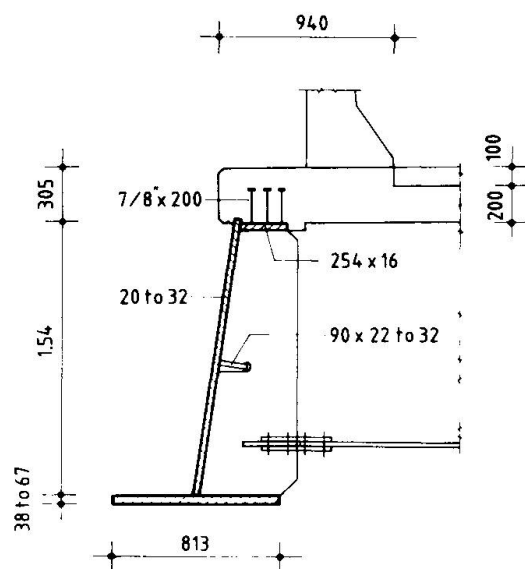

Fig. 3 Edge Girder Detail

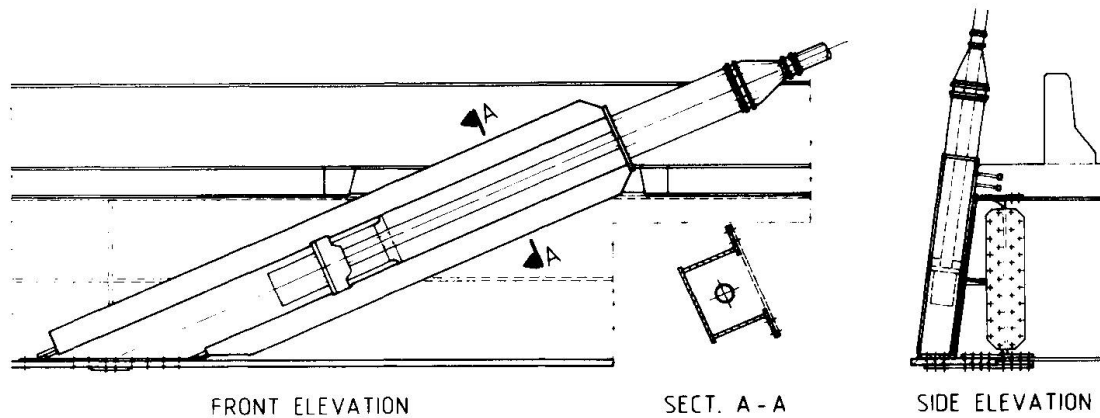

Fig.4 Stay Cable Anchorage at Beam

### 3.2 Design

The overall beam forces under permanent loads were chosen similar to those for a beam rigidly supported at the cable anchorpoints, except for the midspan and end regions where a positive camber is introduced to provide additional compression in the roadway slab. Composite action for dead load was to be achieved by casting the roadway slab onto a continuously supported steel grid on ground. The deck was thus under compression in transverse direction also as top flange of a simply supported girder under dead load.

The shrinkage and creep values were calculated in accordance with the CEB-FIP Model Code [3], which resulted in approximately the following ratios of moduli of elasticity for permanent loads:

$n_0 = 6.0$  initially and for transient loads

$n_1 = 12.5$  at opening for traffic

$n_{\infty} = 18.0$  after creep has taken place

(W/C = 0.35, relat. humidity 75%, age of deck at installation 1 month).

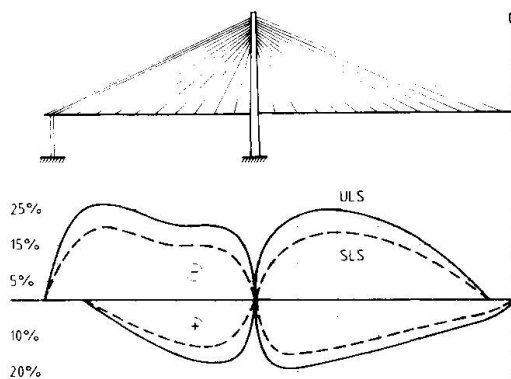

Fig.5 Non-linear increase of Live Load Moments

The overall girder moments due to live load increased by up to 26% in the ultimate limit state due to non-linear effects of the rather slender deck with a main span to depth ratio of about 1 in 200, compare Fig. 4 and [4]. The main girder shear studs are designed for the combined action of local and overall shear, and cable force introduction. An assumed limited amount of slip and plastic deformation of the studs in the ultimate limit state led to the uniform arrangement of shear studs over the length of the beam. The introduction of the shear force from the 300 mm thick concrete edge beam into the regular 200 mm thick slab (see Fig. 3) proved to be critical.

The sizing of the slab was governed by ultimate strength and crack control under service conditions. The plate girder stability was calculated in accordance with [5].

### 3.3 Contractor's Option

Instead of the proposed continuous roadway slab the contractor opted to use precast slabs connected by cast-in-place joints on top of the floor beams. Due to the resulting loss of composite action for dead load this required additional 640 t of structural steel, or an increase of 17% from 121 kg/m<sup>2</sup> to 141 kg/m<sup>2</sup>.

## 4 STAY CABLES

The stay cables were sized in accordance with the PTI-Recommendations [6]. They were specified as shop-fabricated parallel strand HiAm cables in PE-pipes with cement grout and a wrapping with a laminated Tedlar tape, see [4] and [7] for further details.

The structure was designed to permit the exchange of any stay cable in conjunction with a reduction of live load to two lanes and reduced safety factors. Additionally, any stay cable can be accidentally severed under full live load without structural instability.

The contractor opted for in-situ fabricated parallel strand cables with wedge anchorages in PE-pipes and cement grout.

## 5 TOWERS

The towers are shown in Fig. 5. Their legs and the tie beams underneath the decks have box sections with a minimum wall thickness of 305 mm.

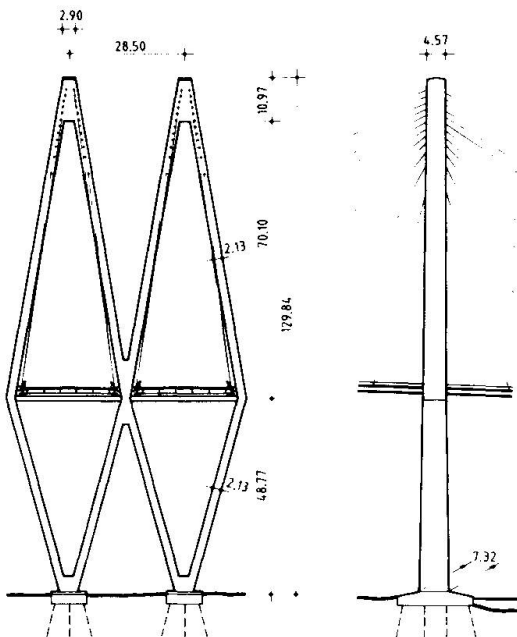

Fig. 6 Tower Layout

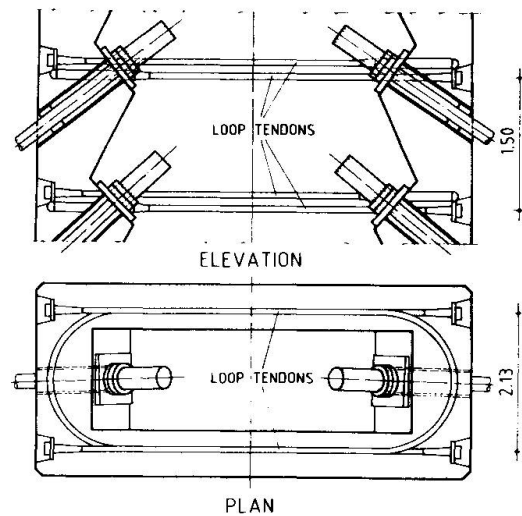

Fig. 7 Tower Cable Anchorage

The double diamond shape is a natural progression from the twin decks. The A-frames on top of the decks reduce the torsional rotations of the beam significantly by forming a triangular space frame, compare [4]. By joining the two lower A-frames at deck level, a truss is created which carries the transverse wind loads in tension and compression to the two foundations. The transverse width of the tower legs can thus be small. In longitudinal direction the tower legs act as cantilevers in bending, especially during construction. Those widths



have thus to be significantly greater. The tie beams act as direct tension members and are fully post-tensioned against the outward thrust from the tower legs.

At the towerhead the stay cables pass through steel pipes embedded in the tower walls, see Fig. 7. They are individually anchored inside on steel bearing plates resting on concrete corbels. The horizontal cable components are tied back with alternating loop tendons so that each cable anchorage region is confined by the radial forces from the loops.

## 6 CONSTRUCTION

From the four foundation alternates shown on the bid drawings the contractor opted to use 500 mm square precast prestressed concrete piles. They were driven from the artificial island on the LaPorte side and the existing levee on the Baytown side, see Fig. 1. 3.60 m thick CIP pile caps formed the basis for the towerlegs.

The towers were built in 4.5 m sections with jumping forms. For the first tower all four legs were built in parallel. For the second tower the two inner lower legs were built first, and then the outer legs were tied back to them.

The beams are constructed by free cantilevering from the towers outwards. The contractor opted to build the two beams in parallel with auxiliary tie-downs. The steel grids for each pair of cables are lifted up and connected in place. The precast slabs are then positioned and the cast-in-place joints poured before proceeding to the next section.

## 7 ACKNOWLEDGEMENT

Owner is the Texas State Department of Highways and Transportation. The cable-stayed main bridge was designed by Greiner, Inc., Tampa, Florida in association with Leonhardt, Andrä and Partners, GmbH, Stuttgart, Germany. Dr. Robert H. Scanlan served as consultant for wind. Williams Brothers Construction Co., Inc., and Traylor Bros., Inc. (a joint venture), are the contractors. The stay cables are supplied by the VSL Corporation.

## REFERENCES

- [1] SCANLAN, R.H.: Dynamic Wind Effects on the Houston Ship Channel Bridge Crossing (Steel Alternative). Report dated 1986.
- [2] REINHOLD, T.A.: Wind Tunnel Aeroelastic Model Study of the Baytown Bridge Steel Alternative, Applied Research Engineering Services, Inc. Report 5101-1, May 29, 1986.
- [3] International Recommendations for the Design and Construction of Concrete Structures, CEB-FIP (1978) Appendix E: "Time Dependent Behavior of Concrete Creep and Shrinkage".
- [4] SVENSSON, H., CHRISTOPHER, B.G. and SAUL, R.: Design of a Cable-Stayed Steel-Composite Bridge. Journal of Structural Engineering, ASCE, Vol.112, No.3, March, 1986, pp. 489-504.
- [5] Proposed Design Specifications for Steel Box Girder Bridges, Federal Highway Administration Report No. FHWA-TS-80-205, January, 1980.
- [6] Recommendations for Stay Cable Design and Testing, by Post Tensioning Institute Ad Hoc Committee on Cable-Stayed Bridges, USA, Jan. 1986.
- [7] SAUL, R. and SVENSSON, H.: On the Corrosion Protection of Stay Cables. Der Stahlbau 4/5, 1990.