

Strength of concrete slab at composite beam-to-column connection

Autor(en): **Igarashi, Sadayoshi / Inoue, Kazuo / Tsujioka, Shiuzo**

Objekttyp: **Article**

Zeitschrift: **IABSE reports = Rapports AIPC = IVBH Berichte**

Band (Jahr): **60 (1990)**

PDF erstellt am: **23.07.2024**

Persistenter Link: <https://doi.org/10.5169/seals-46503>

Nutzungsbedingungen

Die ETH-Bibliothek ist Anbieterin der digitalisierten Zeitschriften. Sie besitzt keine Urheberrechte an den Inhalten der Zeitschriften. Die Rechte liegen in der Regel bei den Herausgebern.

Die auf der Plattform e-periodica veröffentlichten Dokumente stehen für nicht-kommerzielle Zwecke in Lehre und Forschung sowie für die private Nutzung frei zur Verfügung. Einzelne Dateien oder Ausdrucke aus diesem Angebot können zusammen mit diesen Nutzungsbedingungen und den korrekten Herkunftsbezeichnungen weitergegeben werden.

Das Veröffentlichen von Bildern in Print- und Online-Publikationen ist nur mit vorheriger Genehmigung der Rechteinhaber erlaubt. Die systematische Speicherung von Teilen des elektronischen Angebots auf anderen Servern bedarf ebenfalls des schriftlichen Einverständnisses der Rechteinhaber.

Haftungsausschluss

Alle Angaben erfolgen ohne Gewähr für Vollständigkeit oder Richtigkeit. Es wird keine Haftung übernommen für Schäden durch die Verwendung von Informationen aus diesem Online-Angebot oder durch das Fehlen von Informationen. Dies gilt auch für Inhalte Dritter, die über dieses Angebot zugänglich sind.

Strength of Concrete Slab at Composite Beam-to-Column Connection

Résistance de la dalle en béton armé à la
jonction poutre-poteau mixte

Die Festigkeit der Stahlbetonplatte über den zusammengesetzten
Balken an der Verbundträger-Stützen-Verbindung

S. IGARASHI

Professor
Osaka Univ.
Osaka, Japan

Sadayoshi Igarashi, born 1927, received his doctor's degree from Kyoto Univ. He has worked at Osaka Univ. since 1968 and has been a professor since that time. His researches have been concerned with strength and behavior of steel members and connections.

Kazuo INOUE

Assoc. Prof.
Osaka Univ.
Osaka, Japan

Kazuo Inoue, born 1946, received his doctor's degree from Osaka University in 1982. He has been involved mainly in research into the plastic strength and inelastic behavior of steel and composite structures.

S. TSUJIOKA

Lecturer
Hukui Inst. of Techn.
Hukui, Japan

Shizuo Tsujioka, born 1948, received his doctor's degree from Osaka University in 1987. His researches have been concerned with strength and elastic-plastic behaviour of connections.

Tsutomu ARAI

Struct. Engineer
Ohbayashi Corp.
Osaka, Japan

Tsutomu Arai, born 1964, received his master's degree from Osaka University in 1990.

SUMMARY

To calculate the positive bending strength of composite beams at the beam-to-column connection under earthquake load, it is necessary to evaluate the compressive force in the concrete slab. The ultimate compressive force in the slab is limited by the bearing strength at the column face and the shear strength at the column sides. Theoretical expressions are developed for both bearing and shear strength of concrete slabs, and are checked by experimental investigations.

RÉSUMÉ

Afin de calculer la résistance positive à la flexion des poutres mixtes à la jonction poutre-poteau sous charge sismique, il est nécessaire d'évaluer la force de compression dans la dalle en béton armé. La force de compression ultime s'exerçant dans la dalle est limitée par la force portante en tête du poteau et par la résistance au cisaillement des faces latérales du poteau. Les expressions théoriques sont développées pour les deux types de sollicitation, puis elles sont vérifiées par des recherches expérimentales.

ZUSAMMENFASSUNG

Zur Ermittlung des Biege widerstandes von Verbundträgern bei Rahmenknoten unter Erdbebenbeanspruchung ist die Druckkraft in der Betonplatte abzuschätzen. Diese wird beschränkt durch die Druckspannung an der Stützenfront und die Schubspannung an den Seiten der Stütze. Für beide Spannungen wurden theoretische Ansätze entwickelt und durch Versuche abgesichert.



1. INTRODUCTION

When the framed structures are subjected to earthquake loading, both positive and negative bending moment act on composite beams as shown in Fig. 1. The positive bending strength of composite beams is mainly affected by the compressive force in the slab. For the simple composite beams, compressive force in the slab is determined by the effective width of slab which depends on the beam span. However, at the beam-to-column connection, the compressive force in the slab is kept in equilibrium with the bearing stress (C_B) and shear stress (C_S) as illustrated in Fig. 2. So that the ultimate compressive force is limited by the bearing strength at the column face and the shear strength at the column sides. In the case of the square tube column, only the bearing stress is balanced with the slab compressive force.

Empirical value of bearing strength of concrete slab based on push out tests has been suggested by B. Kato et al^[1]. In the present paper, theoretical expressions are developed for both bearing and shear strength of concrete slab. Theory of the concrete plasticity based on the *modified Mohr-Coulomb* criterion is used in the analysis. To examine the theoretical expressions, two series of experimental investigations were intended. One is the push out test to confirm the bearing and shear strength of the slab. In the other series, the composite beam-to-column subassemblages were tested to ensure the positive bending strength of composite beams.

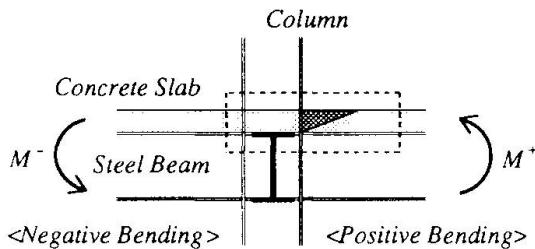

Fig. 1

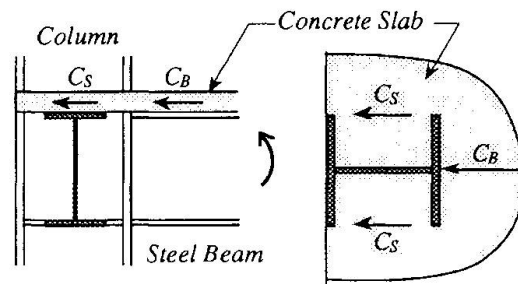

Fig. 2 Transmission of compressive force in the concrete slab

2. THEORETICAL SOLUTIONS OF BEARING AND SHEAR STRENGTH

2.1 Assumptions

To calculate the positive bending strength of composite beams at the beam-to-column connection under the earthquake load, it is necessary to evaluate the compressive force in the concrete slab. Fig. 3 shows the failure model to obtain the ultimate compressive force in the slab. Due to the spreading of the crack resulting from negative bending, no forces can be transmitted on the left side of the column in this figure. Yield lines are developed along the either side of the column, and the wedge of concrete is pushed out from the face of the flange plate of steel column. This model is assumed according to the failure modes observed in the tests. The ultimate compressive force in the slab is limited by the bearing strength at column face and the shear strength along the column sides. Theoretical expressions are developed for both bearing and shear strength of concrete slab based on the following assumptions:

- 1) Steel and concrete are the rigid-plastic material, and concrete obeys the *modified Mohr-Coulomb* criterion.
- 2) The dowel effect of the reinforcement is neglected.
- 3) Friction between concrete slab and the steel column is neglected.
- 4) The drawing strength of headed studs is neglected.

2.2 The Ultimate Compressive Force in the Slab

The solution of the shear strength of reinforced concrete slabs with load in their plane is obtained by B. C. Jensen^[2] and is explained in Ref.[3,4]. The relative displacement which is perpendicular to the yield line along the column side will be

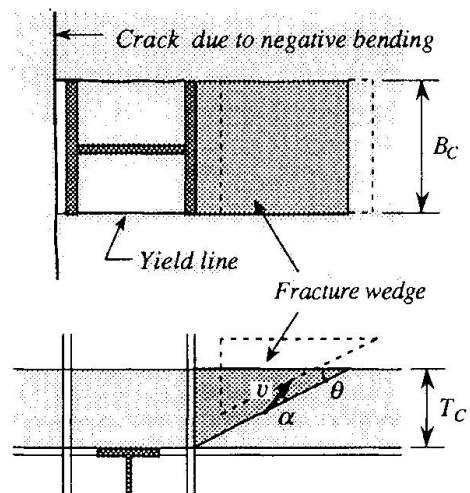

Fig. 3 Failure mode

prevented by the cross beam and the bending rigidity of slab in its plane. So that the ultimate shear stress along the column side is given by the following equation.

$$\frac{\tau_u}{F_c} = \frac{1}{2} v \quad (1)$$

where, F_c is cylinder strength, and v is efficiency factor of concrete strength. The ultimate value of C_s in Fig. 2 is obtained from multiplying τ_u by the area of the column side A_s , that is

$$C_{su} = \frac{1}{2} v F_c A_s \quad (v = \frac{2}{3}) \quad (2)$$

Next, the bearing strength at the column face is derived from the following. Fig. 4 shows the forces act on the failure wedge. Assuming that the vertical load does not act on the wedge, the maximum principal stress (σ_1) and the minimum principal stress (σ_3) take the direction shown in Fig. 4. The direction of σ_1 coincides with the longitudinal axis of the composite beam. σ_3 is perpendicular to the plane of slab and equals to 0. Clearly, the intermediate principal stress (σ_2) perpendicular to σ_1 - σ_3 plane is compressive; then it has no influence on the failure. Mohr's circles corresponding to the stress field of the sliding plane are drawn in Fig. 5 together with the *modified Mohr-Coulomb* criterion. From this figure, it is evident that the sliding plane forms the angle $\theta = 45^\circ - \phi/2$ with the slab surface. The angle of friction ϕ takes the value of 37° ^[3,4]. The normal stress σ and the shear stress τ lie on the point P in Fig. 5, and are given by

$$\sigma = \frac{F_c}{2} (1 - \sin \phi), \quad \tau = \frac{F_c}{2} \cos \phi \quad (3)$$

The ultimate shear stress on the triangular shear planes of either side of the failure wedge is given by eq.(1). For the equilibrium of the failure wedge shown in Fig. 4 including the yield axial force of reinforcement bar, the average bearing stress (F_B) can be expressed as:

$$\frac{F_B}{F_c} = 1 + \frac{v T_c}{2 B_c \tan \theta} + \frac{r a \cdot r \sigma_y}{F_c T_c B_c} \quad (4)$$

in which, B_c is the width of column, T_c is the thickness of slab, $r a$ and $r \sigma_y$ are the total area and the yield stress of reinforcement bar, respectively. The resultant bearing strength C_{BU} is obtained from multiplying F_B by the area of the column face, and the location of C_{BU} is determined by the equilibrium condition, as follows:

$$C_{BU} = F_B T_c B_c, \quad d_c = \frac{F_c}{F_B} \left(\frac{T_c}{2} + \frac{v T_c^2}{6 B_c \tan \theta} + \frac{d_r \cdot r a \cdot r \sigma_y}{F_c T_c B_c} \right) \quad (5)$$

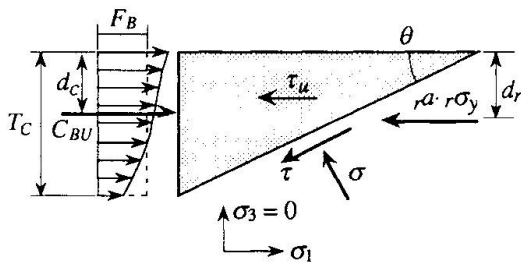

Fig. 4 Forces on failure wedge

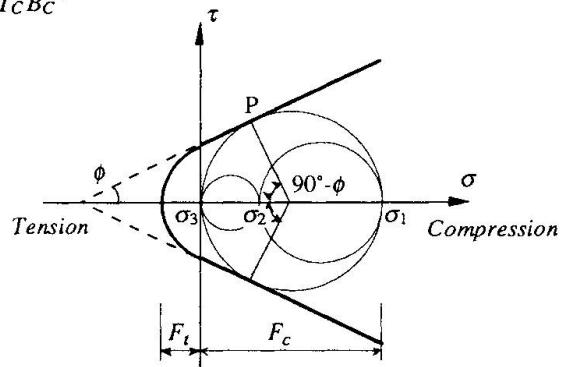

Fig. 5 Fracture criteria and Mohr's circle

3. PUSH OUT TEST OF CONCRETE SLAB

Three types of push out test specimens of concrete slab were considered : bearing tests, shear tests, and the tests combining bearing and shear. Fig. 6 (a) and (b) show the bearing and shear test specimens, respectively. For the bearing specimens (B-type), slits of the slab are made on either side of H-shaped column to avoid the effect of shear, and for the shear specimens (S-type), a slit is made on the face of the column so as not to cause the bearing force. BS-type specimens have no slits, and are subjected to bearing and shear force simultaneously. The principle variables are the thickness of slab. The list of specimens and the test results are summarized in Table 1. For each kind, the two same specimens were used. The mechanical properties of materials are also shown beside Table 1.



Specimen	T_C (mm)	P_{max} (kN)	ϵ_B ($\times 10^{-6}$)	$P_{max}/A_C F_C$		Test Analysis
				Test	Analysis	
B1-1	100	789	1790	1.44	1.31	1.10
B1-2		791	1700	1.45		
B2-1	145	1093	2210	1.38	1.45	0.95
B2-2		1097	2380	1.39		
S1-1	100	432	1770	0.79	0.58	1.36
S1-2		434	1740	0.79		
S2-1	145	596	2160	0.75	0.58	1.29
S2-2		530	1830	0.67		
BS1-1	100	1098	1960	2.01	1.90	1.06
BS1-2		1100	2150	2.01		
BS2-1	145	1615	2160	2.04	2.03	1.00
BS2-2		1656	2750	2.09		

$A_C = B_C T_C$: Bearing area

Mechanical Properties

Concrete : $F_C = 21.9\text{MPa}$
 $F_t = 2.61\text{MPa}$

Reinforcement : $\sigma_y = 356\text{MPa}$
 $\sigma_B = 510\text{MPa}$

Table 1 Summary of specimens and Test Results

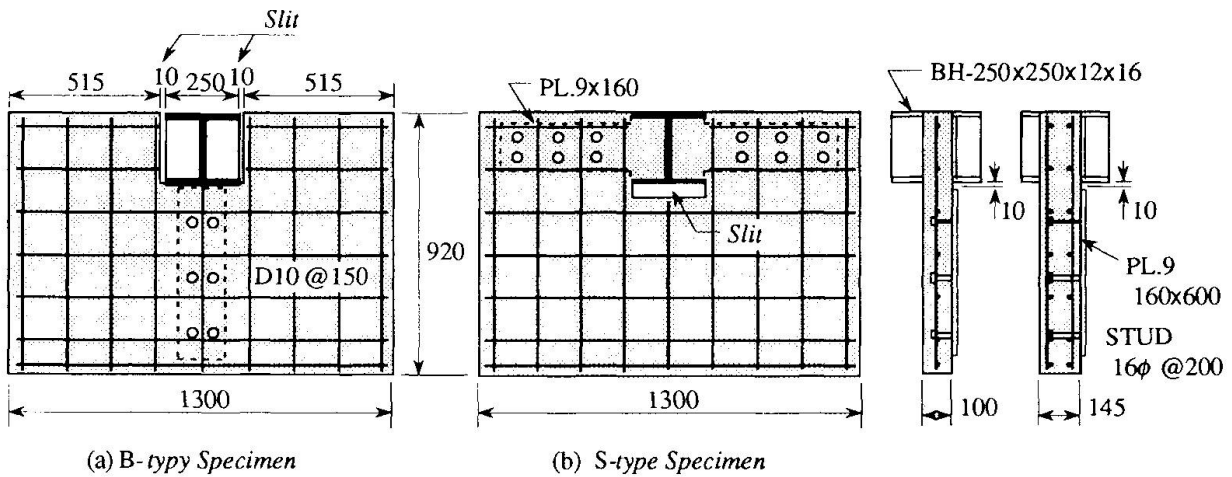

Fig. 6 Push out test specimens

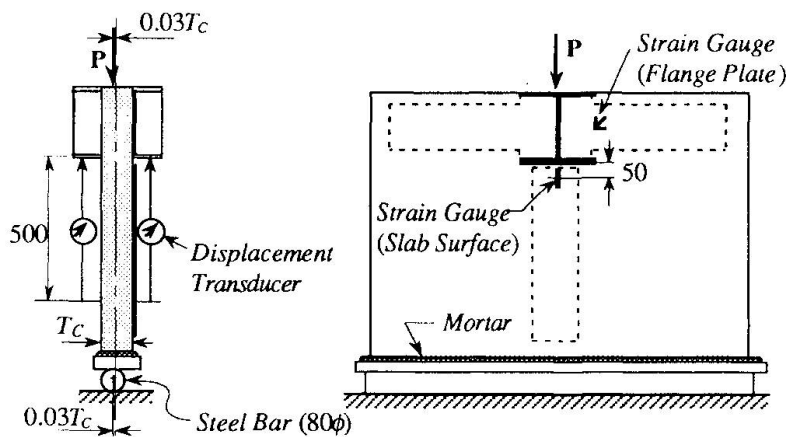

Fig. 7 Test setup

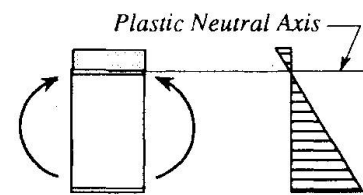
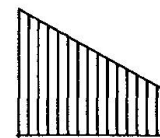

Fig. 8 Strain distribution of composite beam



B1-1
 Fig. 9 Strain distribution of B1-1 specimen

An outline of the test procedure is shown in Fig. 7. To give the strain inclination along the section of slab which occurs in the actual composite beam (see Fig. 8), load is applied on all specimens with eccentricity 3% of the slab thickness as shown in Fig. 7. As an example, the distribution of strain along the section of B1-1 specimen at the maximum load is shown in Fig. 9. Hereafter, an average strain of the middle surface of the slab determined by the measured values of displacement transducers located on both sides of the slab is taken as the representative value. In Table 1, P_{max} is the maximum load, and ϵ_B is the average strain of the middle surface corresponding to P_{max} .

As shown in Fig. 6, thin steel plates corresponding to the upper flange of the steel beam, on which the headed studs are welded, are placed on one side of the concrete slab. The vertical steel plate of B-type specimens is placed with the column and the plate kept 10 mm apart so as to prevent supporting the load. Next, the horizontal steel plates in S-type specimens, which correspond to the upper flange of the cross beam, support part of load. This load is calculated from the data measured by strain gauges, and is subtracted from the test results such as P_{max} .

The relations between load (P) and the average strain (ϵ) of concrete slab are summarized in Fig. 10 in which load P is nondimensionalized by $A_c F_c$. All these relations indicate the average of the two same specimens. Horizontal lines show the theoretical ultimate load levels obtained from eq.(2) and eq.(5). P - ϵ relations of BS-type are compared with the superposed P - ϵ relations of B-type and S-type specimens (indicated by dashed line).

Table 1 and Fig. 10 lead to the following: The strain ϵ_B , at which the maximum load is reached, takes the approximate value of 0.002 for all specimens. Consequently, the bearing strength and the shear strength can be simply superposed.

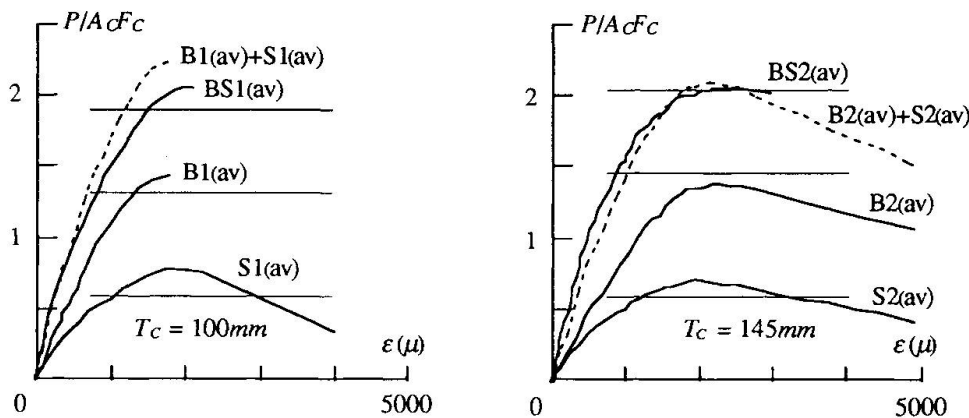

Fig.10 Load-to-average strain relations of push out test specimens

4. TEST RESULTS OF COMPOSITE BEAM-TO-COLUMN SUBASSEMBLAGE

The dimensions and member sizes of composite beam-to-column subassembly are shown in Fig. 11. Both H-shaped and square tube section were used for the steel column. To ensure the effect of the beam span on positive bending strength, two kinds of beam length were selected. The specimen with bare steel beam is also tested to confirm the composite effect.

The earthquake type of force were repeatedly applied to all specimens. Only the initial part of the beam end moment (M)-to-beam rotation (θ) relations are shown in Fig. 11. Fig. 12 shows the failure mode of concrete slab connected to H-shaped column, which verifies the validity of the assumed failure model shown in Fig. 3.

By calculating the compressive force in the slab from eq.(2) and eq.(5), the positive bending strength of composite beams is easily obtained^[5]. Horizontal lines in Fig. 11 indicate the theoretical positive bending strength. The theory proposed here proves that positive bending strength depends only on the boundary condition of the beam-to-column connection. The strength of composite beam connected to a H-shaped column is greater than that of composite beam connected to a square tube column as predicted theoretically. This is due to the additional shear resistance of H-shaped column sides. The fact that the

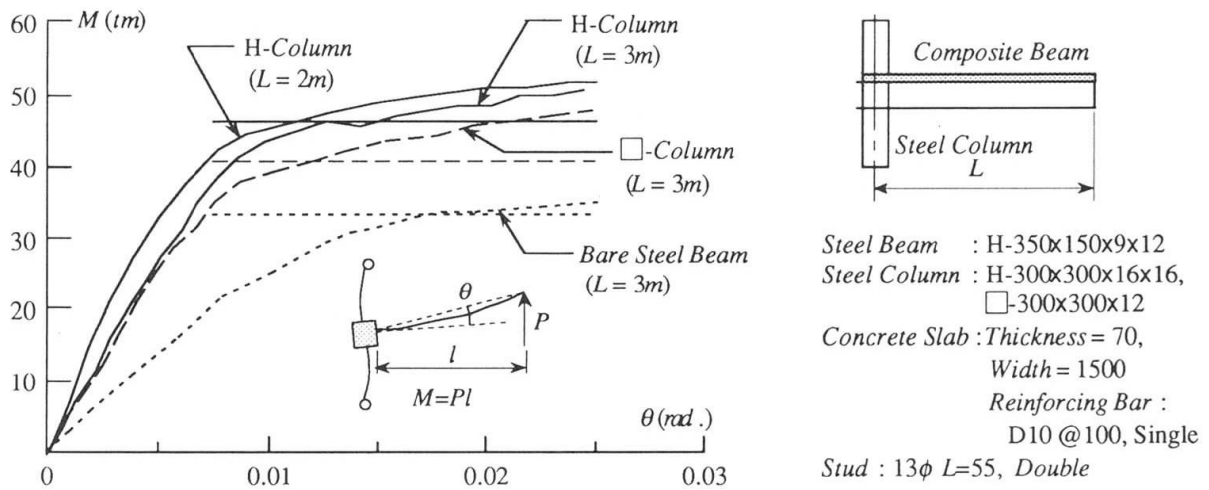

Fig. 11 Moment-rotation curves of composite beams and test specimens

difference of beam span does not affect the positive bending strength is also confirmed by comparing the test results from beams of different length.

5. CONCLUSION

The ultimate compressive force in the slab is limited by the bearing strength at column face and the shear strength at the column sides. So that the positive bending strength of composite beams is affected by the boundary condition of the beam-to-column connection under the earthquake type of loading. Theoretical expressions based on the concrete plasticity are developed for both bearing and shear strength of concrete slabs. The validity of the theory was confirmed through the push out tests of reinforced concrete slabs and the tests of composite beam-to-column subassemblages.

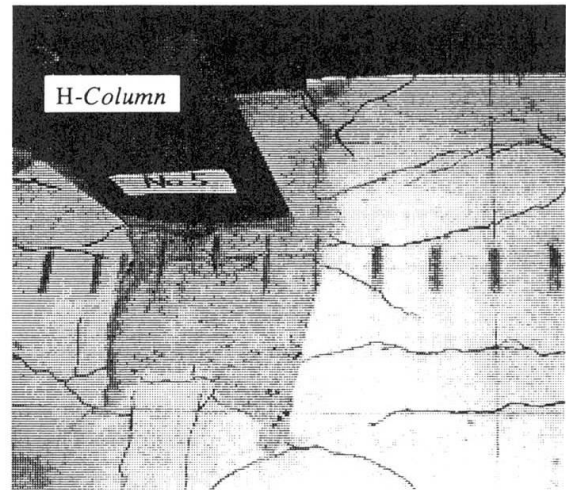

Fig. 12 Failure mode of concrete slab

ACKNOWLEDGMENTS

The authors are grateful to Lecturer Eiji Tateyama of Kinki University for his help in the tests of the composite beam-to-column subassemblage.

REFERENCES

1. KATO B. and TAGAWA Y., Strength of Composite Beams under Seismic Loading. The Second US-Japan Joint Seminar on Composite and Mixed Construction, Univ. of Washington, pp.42-49, July 1984.
2. JENSEN B. C., Lines of Discontinuity for Displacements in the Theory of Plasticity of Plane and Reinforced Concrete. Magazine of Concrete Research, Vol.27, No.92, pp.143-150, September 1975.
3. CHEN W.F., Plasticity in Reinforced Concrete. McGraw-Hill, 1982.
4. NIELSEN M.P., Limit Analysis and Concrete Plasticity. Prentice-Hall, Inc., 1984.
5. HANSELL W.C. and GALAMBOS T.V. et al, Composite Beam Criteria in LRFD. Proc. of ASCE, ST9, pp.1409-1441, September 1978.