

Development of mixed structures in Japan

Autor(en): **Ogura, Koichirou / Tanaka, Reiji / Noguchi, Hiroshi**

Objekttyp: **Article**

Zeitschrift: **IABSE reports = Rapports AIPC = IVBH Berichte**

Band (Jahr): **60 (1990)**

PDF erstellt am: **23.07.2024**

Persistenter Link: <https://doi.org/10.5169/seals-46519>

Nutzungsbedingungen

Die ETH-Bibliothek ist Anbieterin der digitalisierten Zeitschriften. Sie besitzt keine Urheberrechte an den Inhalten der Zeitschriften. Die Rechte liegen in der Regel bei den Herausgebern.

Die auf der Plattform e-periodica veröffentlichten Dokumente stehen für nicht-kommerzielle Zwecke in Lehre und Forschung sowie für die private Nutzung frei zur Verfügung. Einzelne Dateien oder Ausdrucke aus diesem Angebot können zusammen mit diesen Nutzungsbedingungen und den korrekten Herkunftsbezeichnungen weitergegeben werden.

Das Veröffentlichen von Bildern in Print- und Online-Publikationen ist nur mit vorheriger Genehmigung der Rechteinhaber erlaubt. Die systematische Speicherung von Teilen des elektronischen Angebots auf anderen Servern bedarf ebenfalls des schriftlichen Einverständnisses der Rechteinhaber.

Haftungsausschluss

Alle Angaben erfolgen ohne Gewähr für Vollständigkeit oder Richtigkeit. Es wird keine Haftung übernommen für Schäden durch die Verwendung von Informationen aus diesem Online-Angebot oder durch das Fehlen von Informationen. Dies gilt auch für Inhalte Dritter, die über dieses Angebot zugänglich sind.

Development of Mixed Structures in Japan

Développement des structures mixtes au Japon

Entwicklung von Verbundtragwerken in Japan

Koichirou OGURA

Professor
Meiji University
Kawasaki, Japan



Koichirou Ogura, born 1924, received D.Eng. from the Univ. of Tokyo in 1954. His research interests include the seismic design of RC structures. He is a Chairman of JCI Committee on Mixed Structures.

Reiji TANAKA

Professor
Tohoku Inst. Techn.
Sendai, Japan

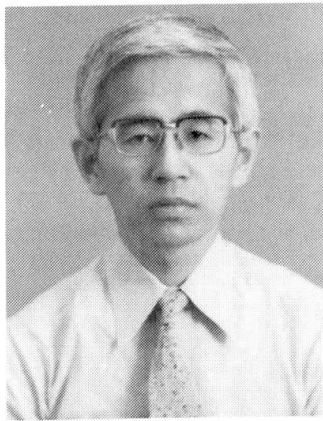

Reiji Tanaka, born 1940 received D.Eng. from Meiji Univ. in 1971. His research interests include the seismic design of RC structures. He is a Secretary of AIJ RC Committee and JCI Committee on Mixed Structures.

Hiroshi NOGUCHI

Assoc. Professor
Chiba University
Chiba, Japan



Hiroshi Noguchi, born 1946 received D.Eng. from the Univ. of Tokyo in 1976. His research interests include the seismic design of RC structures and the application of FEM. He is a member of IABSE, AIJ, JCI.

SUMMARY

This paper introduces the state-of-the art concerning research on mixed structures using concrete systems in building construction in Japan. The classifications of structures defined in building regulations, proposals for definitions of mixed structures, various structural codes defined by Architectural Institute of Japan and previous researches on mixed structures are introduced.

RÉSUMÉ

Cet article présente l'état actuel de la technique dans le domaine de la recherche sur les structures mixtes, utilisant un système pratique pour la construction des bâtiments au Japon. Ce rapport fournit les classifications des structures telles que définies par les règlements de la construction, des propositions de définition des structures mixtes, divers codes structuraux mis au point par l'Institut d'architecture du Japon, ainsi que des études antérieures sur les structures mixtes.

ZUSAMMENFASSUNG

Dieser Beitrag beschreibt den Stand der Forschung betreffend Verbundtragwerken aus Stahl und Beton in Japan. Die Klassierung der Bauwerke in den Normen und Vorschläge zur Definition von Verbund- und Mischbauwerke werden besprochen, sowie auch die bisherige Forschung zu diesem Thema in Japan.



1. INTRODUCTION

The purpose of this paper is to introduce comprehensively the state-of-the-art on the research on the mixed structures using concrete system in Japan. The mixed structure using concrete system is defined as the mixed structures of concrete members and steel members. The mixed structures using the concrete system is greatly utilized in both fields of building construction and civil engineering construction in Japan. The mixed structures in the building construction is only introduced in this paper.

2. CLASSIFICATION OF BUILDING STRUCTURES IN JAPAN

2.1 Classification of Structures Determined in Building Regulation

The buildings are constructed in accordance with the building regulation in Japan. Five kinds of building structures such as reinforced concrete (RC), steel reinforced concrete (SRC), steel (S), wood and masonry are defined in the Japanese building regulation. The mixed structures are frames which are composed of the above various kinds of structures. But there is not a present legal prescription with regard to the mixed structures. Therefore, when the mixed structure frames are constructed, it is necessary for the constructor to design in accordance with the various structural code published by Architectural Institute of Japan (AIJ) or to receive an evaluation from Building Center of Japan after the special research is carried out for the designed structures.

2.2 Various Structural Codes Defined by AIJ

Though building structures are designed in accordance with the building regulation, the detailed mechanical items necessary for the design are not defined in this regulation. Thereupon, the building structures are designed generally in accordance with various structural codes of AIJ in Japan.

The design method of each structure is shown in detail in each structural code of AIJ, but this code has no restriction imposed by law. The following code of AIJ is related to the mixed structures using concrete system.

- 1) Standard for Structural Calculation of Reinforced Concrete Structures (RC Code)
- 2) Standard for Design of Steel Structures (S Code)
- 3) Standard for Structural Calculation of Steel Reinforced Concrete Structures (SRC Code)
- 4) Standard for Design of Composite Structures
- 5) Standard for Design and Construction of Prestressed Concrete Structures

General examples of the section used in RC, SRC and S structural design code are shown in Fig. 1.

The strength ranges of materials used in each code are as follows; the compressive strength of concrete, $F_c = 14.7 - 35.3$ MPa, the yield strength of reinforcement, $\sigma_y = 235 - 392$ MPa and the yield strength of steel, $\sigma_y = 216 - 402$ MPa. The actual material strengths in the previous tests

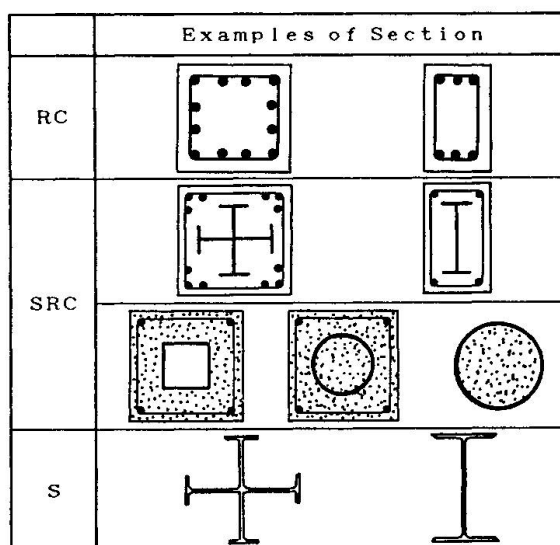
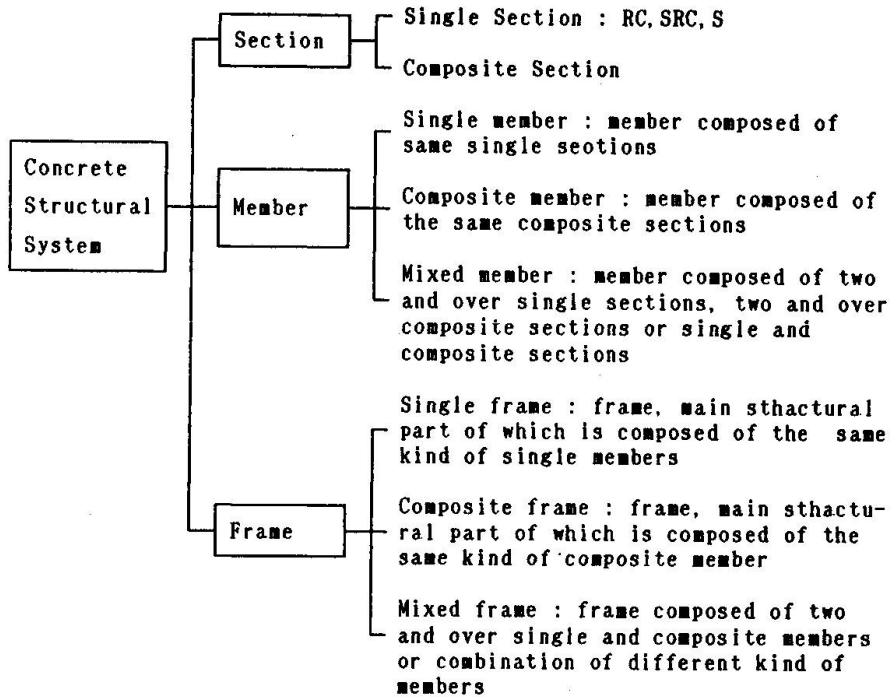

Fig.1 Examples of Sections in RC, SRC and S Structures in Japan

Table 1 Proposed Definitions on Mixed Structures



introduced in this paper are almost in this range.

3. PROPOSALS FOR DEFINITIONS OF MIXED STRUCTURES

As there is not a legal definition regarding mixed structures in Japan, it is necessary to define the mixed structures. The tentative definitions of the mixed structures have been proposed by Japan Concrete Institute (JCI) Research Committee on Mixed Structures (Chairman: Prof. K. Ogura). The proposal in Table 1 is distinguished by the definition of mixed frame using sections, members and frames.

4. PREVIOUS RESEARCHES

If mixed structures are composed of different structural members as shown in Table 1, the previous research on mixed structures in buildings in Japan are classified into the following three kinds.

- 1) Study on column bases on the lowest floor in steel or steel reinforced concrete structures
- 2) Study on connections between foundation pile and foundation slab
- 3) Study on superstructures

The superstructures in 3) are introduced in this paper.

The following two kinds of mixed structures using concrete system,

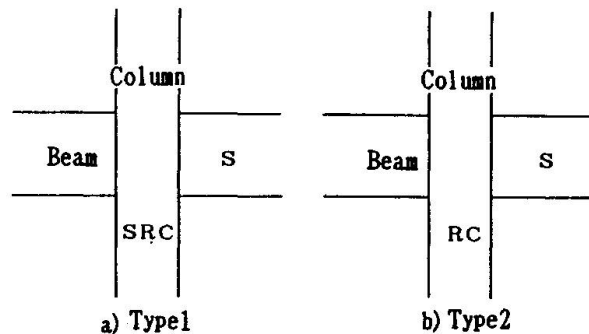

Fig.2 Typical Mixed Structures Studied in Japan



as shown in Fig. 2, have been studied popularly.

- 1) Type 1: column (SRC) + beams (S)
- 2) Type 2: column (RC) + beams (S)

There are few researches on other types such as columns (SRC) + beams (SC), columns (SC) + beams (S) or columns (SRC) + beams (composite beams).

The objects of the mixed structures in Japan are simplification of the prefabrication and the possibility of light weight design and long beam span. In the mixed structures, Type 1 and Type 2, the columns are made by concrete system. This is because of the structural merit that the axial force is contributed by RC structure and the local deformation of steel frames is restrained by concrete. The emphasis of the research on the mixed structures have been moved from on Type 1 to on Type 2. The research committees have been organized in JCI and AIJ, but the building code on mixed structures have not been proposed. Although the research on Type 1 was started from 1972 [1], the research on Type 2 has become popular in 1985 [2], and there are not so many previous researches on Type 2. The movement of the research emphasis from Type 1 to Type 2 is considered to be based mainly on the economical aspects. It is because columns made by RC is more economical than those made by SRC. The main reason why the research on mixed structures was started from Type 1 in Japan is easiness of the joint design between columns and beams. In the research on Type 1, there are many experimental works on the stress transfer mechanisms in beam-column joints. Various types of joints such as interior [1], exterior [3] and corner have been tested. For Type 1, there are also many practical design examples including a high-rise building of 36 stories [4].

It is recognized that there are no particular problems in frame behaviour, if the joint of steel between a column and beams is designed carefully for the type 1. The structure of Type 1 was defined in SRC code. The minimum value of steel in a column is restricted by Eq. (1) in SRC code as follows.

$$0.4 \leq s_c M_A / s_b M_A \leq 2.5 \quad (1)$$

where $s_c M_A$ = sum of flexural strength of steel in column members

$s_b M_A$ = sum of flexural strength of steel in beam members

The main problem in Type 2 is a jointing method between a RC column and steel beams. This problem has been investigated in most of the previous experimental studies. Type 2 is a structure that has lost the steel in a column of Type 1. The change of the mechanical performance from Type 1 to Type 2 was observed in the previous test by Wakabayashi, M. et al. shown in Fig.3 [5]. The beams were made of steel and same for all specimens in this test. If the amount of steel is sufficient in a column like specimen S1002N, the joint behaviour is satisfactory. But as the amount of steel in a column decreases, the hysteresis loop comes to be contrary S-typed, and the joint performance deteriorates. The joint failure occurred in a specimen S0002N in which the amount of steel was zero.

It is difficult to joint a RC column and steel beams simply as observed in the previous test shown in Fig. 3. Therefore, various methods have been considered in the viewpoint of reinforcing a joint using steel plates or frames in a part of the joint, as shown in Fig. 4 [6] - [9]. These considerations tried to transfer a part of beam stresses into a column by strengthening bearing forces of concrete in a reinforced concrete column using beam steel frames, by the confined effects of joint concrete made by steel reinforcing and through the part of steel frames.

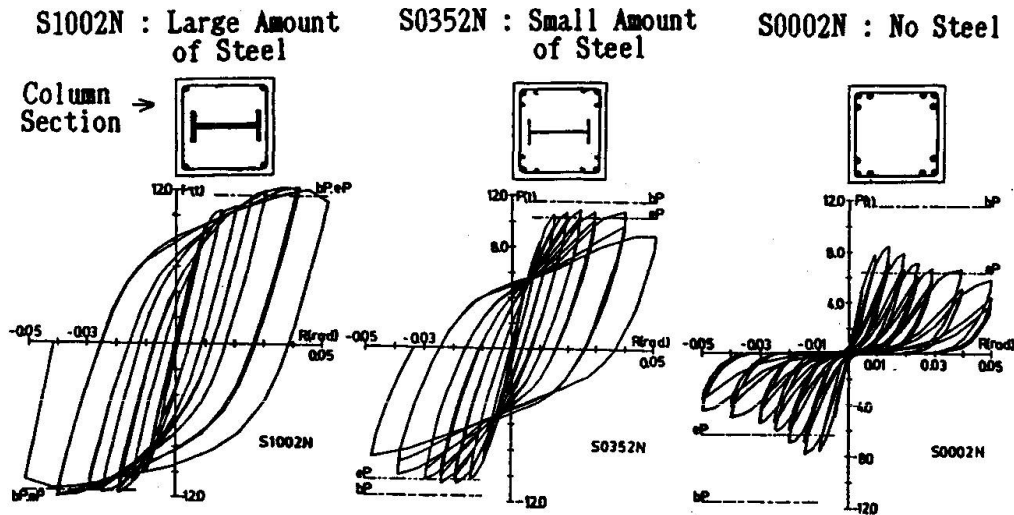
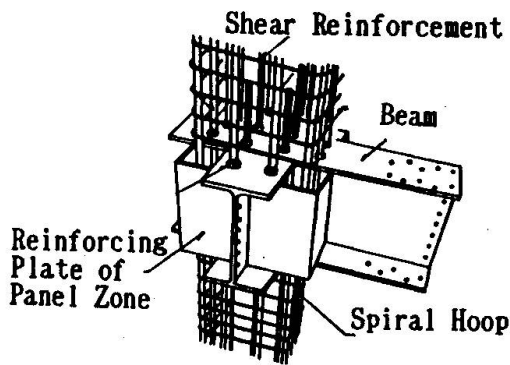
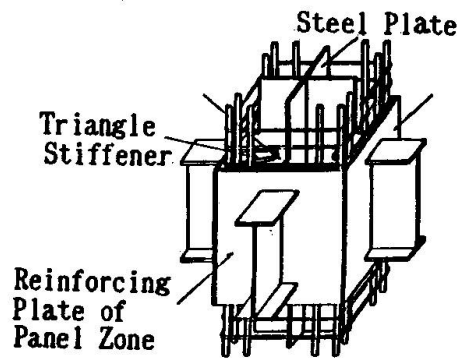

Fig.3 Test Results on Beam-Column Joints from Type 2 (RC Column) to Type 1 (SRC Column) (Wakabayashi, M. et al. [5])



(a)Tominaga, H. et al. [6]



(b)Tanaka, Y. et al. [7]

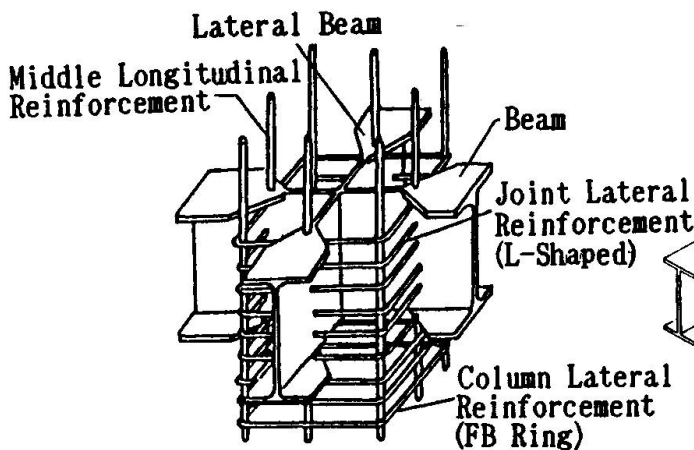

(c)Morota, M. et al. [8]

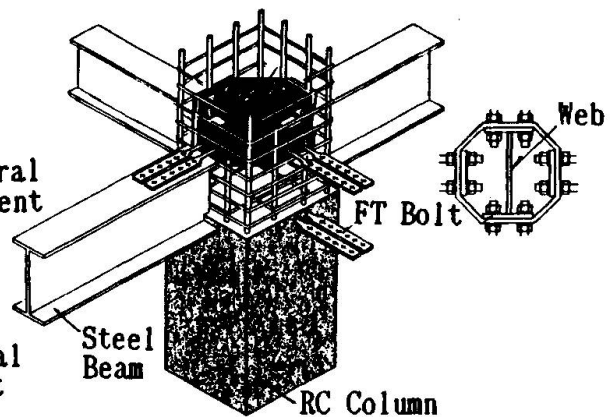

(d)Suzuki, K. et al. [9]

Fig.4 Jointing Methods between RC Column and S Beams in Previous Researches



5. CONCLUDING REMARKS

It had been a general custom to design a building structures using the same kind of structure in Japan. This is because the analysis of frames was difficult in the case that the building was composed of various kinds of structures. It is also the reason that the test data on the mechanical performances of a joint between different structural members was insufficient.

The analytical methods of the mixed structures have been developed using macroscopic and microscopic models with the development of computers. These present situations develop a tendency to utilize the performance of each member of SRC, RC and S in the design in accordance with each aptitude. Such design philosophies are considered to be a main current in the future building structures in Japan. The studies on mixed structures will be more prosperous in cooperation with the studies on building construction.

References

1. Takeda, T. et al., Experimental Studies on Structures Using Steel and Steel R/C, Abstracts, Annual Meeting of AIJ, October 1972, pp. 1509-1510 (In Japanese).
2. K.Iwaguchi, K. et al., Stress Transferring Mechanism of Interior Joints in Mixed Structures, Abstracts, Annual Meeting of AIJ, October 1985, pp.1311-1312 (In Japanese).
3. Naka, T. et al., Experimental Studies on the Strength of Steel R/C Beam-Column Joints, Abstracts, Annual Meeting of AIJ, October 1972, pp.2283-2284 (In Japanese).
4. Yokoyama, M. et al., Study on Structure of Super High-Rise Housing with Y-Shaped Plan (Part 1-Structural System and Design Concept), Abstracts, Annual Meeting of AIJ, October 1984, pp.2805-2806 (In Japanese).
5. Wakabayashi, M. et al., Load Carrying Capacity of Composite Exterior Joints with Steel Beam (Part 3), Abstracts, Annual Meeting of AIJ, October 1984, pp.2761-2762 (In Japanese).
6. Tominaga, H. et al., Strength and Ductility of Frames Composed of RC Columns and Steel Beams, Abstracts, Annual Meeting of AIJ, August 1986, pp.1427-1428 (In Japanese).
7. Tanaka, Y., Strength and Deformability of Steel Beam-Reinforced Column Joints, Abstracts, Annual Meeting of AIJ, October 1987, pp.1331-1332 (In Japanese).
8. Morota, M. et al., Experimental Study on Reinforced Concrete Column to Steel Beam Joints of Tapered-flange-type Panels, Abstracts, Annual Meeting of AIJ, October 1988, pp.1315-1316 (In Japanese).
9. Suzuki, K. et al., Structural Behaviour of Steel Beam-to-Reinforced Concrete Column Connections Using Particular Shaped High-Strength Bolts, Abstracts, Annual Meeting of AIJ, October 1989, pp.1567-1568 (In Japanese).