

Basic concept for using concrete tensile strength

Autor(en): **König, Gert / Duda, Herbert**

Objektyp: **Article**

Zeitschrift: **IABSE reports = Rapports AIPC = IVBH Berichte**

Band (Jahr): **62 (1991)**

PDF erstellt am: **23.07.2024**

Persistenter Link: <https://doi.org/10.5169/seals-47692>

Nutzungsbedingungen

Die ETH-Bibliothek ist Anbieterin der digitalisierten Zeitschriften. Sie besitzt keine Urheberrechte an den Inhalten der Zeitschriften. Die Rechte liegen in der Regel bei den Herausgebern.

Die auf der Plattform e-periodica veröffentlichten Dokumente stehen für nicht-kommerzielle Zwecke in Lehre und Forschung sowie für die private Nutzung frei zur Verfügung. Einzelne Dateien oder Ausdrucke aus diesem Angebot können zusammen mit diesen Nutzungsbedingungen und den korrekten Herkunftsbezeichnungen weitergegeben werden.

Das Veröffentlichen von Bildern in Print- und Online-Publikationen ist nur mit vorheriger Genehmigung der Rechteinhaber erlaubt. Die systematische Speicherung von Teilen des elektronischen Angebots auf anderen Servern bedarf ebenfalls des schriftlichen Einverständnisses der Rechteinhaber.

Haftungsausschluss

Alle Angaben erfolgen ohne Gewähr für Vollständigkeit oder Richtigkeit. Es wird keine Haftung übernommen für Schäden durch die Verwendung von Informationen aus diesem Online-Angebot oder durch das Fehlen von Informationen. Dies gilt auch für Inhalte Dritter, die über dieses Angebot zugänglich sind.

Basic Concept for Using Concrete Tensile Strength

Concept de base visant l'utilisation de la résistance en traction du béton

Überlegungen zur Ausnutzung der Betonzugfestigkeit

Gert KÖNIG

Professor
Techn. Hochschule
Darmstadt, Germany



Gert König, born 1934. Since 1970 partner in a consulting office. Since 1975 Professor in the faculty of civil engineering at the Technische Hochschule of Darmstadt.

Herbert DUDA

Civil Eng.
Techn. Hochschule
Darmstadt, Germany

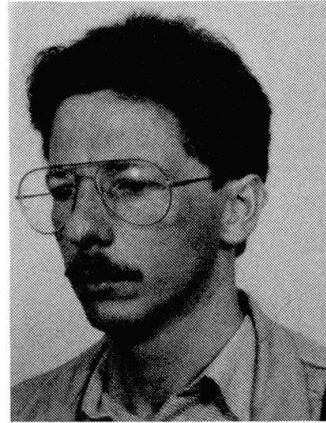

Herbert Duda, born 1958, obtained his civil engineering degree at the Technische Hochschule Darmstadt, he is currently an assistant at the Institut für Massivbau.

SUMMARY

A mechanical model is presented which is able to predict strain softening of concrete in tension. An arbitrary loading history can be described. Scale effects are taken into account. The report includes a critical review of test set-ups to study the material properties of concrete in tension. Finally, a basic concept for using concrete tensile strength in design is described.

RÉSUMÉ

Un modèle mécanique est présenté qui permet de relever la baisse de la résistance à la traction d'un béton mis en tension. L'évolution de la mise en charge est décrite, de même que l'on tient compte des effets de l'échelle de mesure. L'article présente également un rapport critique sur les installations utilisées dans l'étude de la résistance à la traction du béton. Finalement, un concept de base est donné pour utiliser à bon escient cette résistance lors du dimensionnement de structures.

ZUSAMMENFASSUNG

Es wird ein mechanisches Modell vorgestellt, das das Verformungsvermögen von Beton unter Zugbeanspruchung mit den wesentlichen Abhängigkeiten beschreibt. Eine beliebige Lastgeschichte kann damit verfolgt werden. Es können Massstabeffekte beschrieben und Versuchsaufbauten zur Bestimmung des Verhaltens von Beton auf Zug kritisch diskutiert werden. Schliesslich werden Aussagen zur Ausnutzung des Betons auf Zug bei der Dimensionierung der Tragwerke gemacht.



1. INTRODUCTION

In general, concrete is considered to be a brittle material. Especially in the case of tensile loaded concrete a very brittle behavior is expected, but in some cases, e.g. anchorage, tensile loaded concrete exhibits a very ductile behavior, also. In the case of pure bending, concrete may exhibit a ductile behavior. Figure 1 shows three load-crack-mouth-opening displacement curves (Load-CMOD-curve) [16]. The test specimen were notched beams under three point bending. They were made of HSC (C80) which is normally judged to be brittle; nevertheless, the behavior was ductile. The brittleness or ductility of concrete is not only governed by the material behavior but to the same extend by the size and the loading conditions.

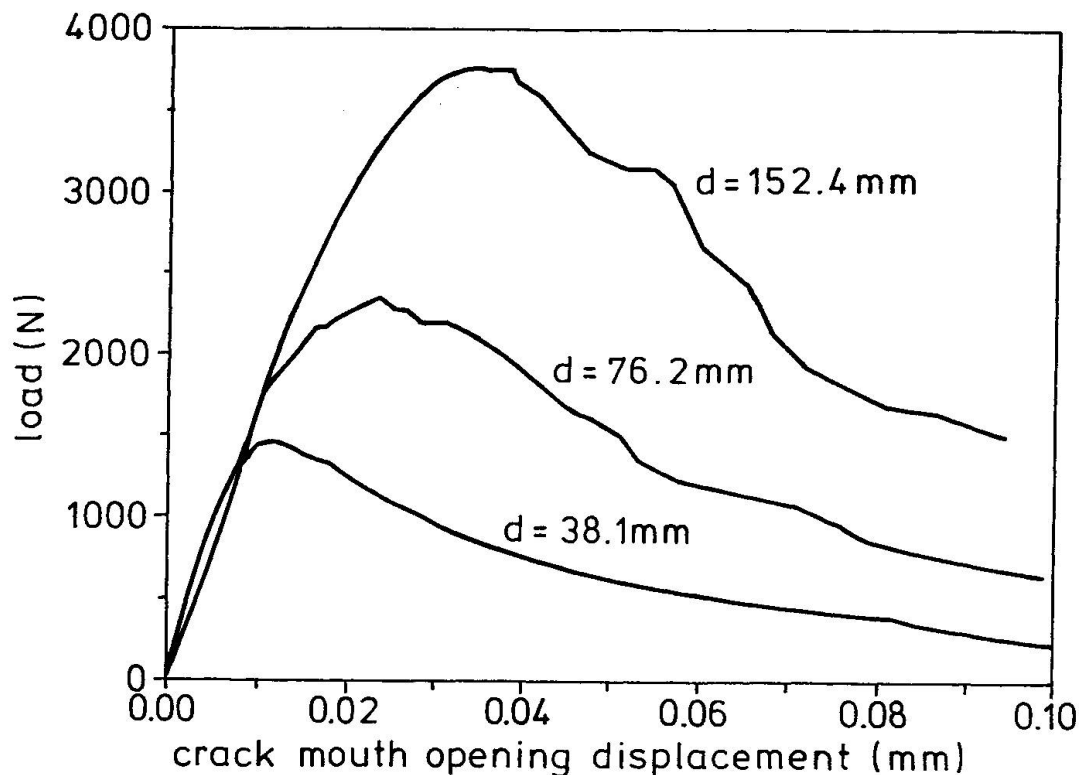

Fig. 1: Load - CMOD - curve for different depths d

2. MODELING OF STRAIN SOFTENING

The ductility or brittleness of concrete depends on the strain-softening behavior of concrete. There is a big difference in strain softening of concrete and e.g. steel. Having passed the yield point, steel first shows a strain hardening and after reaching the tensile strength, a strain softening behavior. Concrete shows no - or almost no - strain hardening. The strain softening starts immediately after the elastic limit is reached, it occurs due to cracking and not due to yielding as in steel.

The tensile behavior of concrete may be explained by Figure 2. A deformation controlled centric tension test may be undertaken at the specimen shown in Figure 2 left. The specimen is loaded with the force P . The total deformation is measured over the length l . On the left side of Figure 2 the specimen is plotted for the load steps A, B and C. The load steps are marked also at the load-deformation-curve on the right side. Load step A is before peak load; load step B at peak load and load step C after peak load, at the descending branch of the load displacement curve.

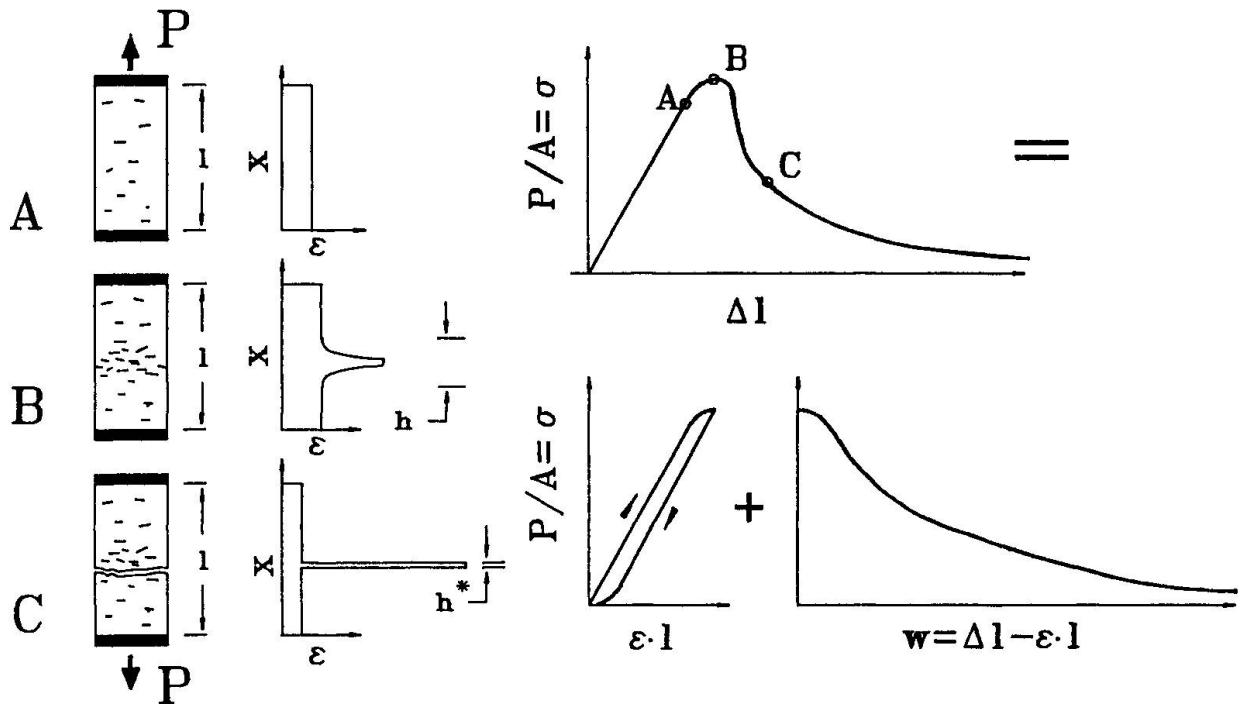

Fig. 2: Tensile behavior of concrete

Even before the peak load is reached, some micro-cracking occurs (Fig. 2A). As the micro-cracking is uniformly distributed on the macro level, a uniform strain over the length of the specimen may be assumed. The strain ε is plotted over the length of the specimen in Fig. 2, next to the specimen.

Immediately before the peak load an accumulation of micro-cracking occurs at the weakest part of the specimen. On the macro level this leads to an additional strain over the length h of this weak part. A crack band with the crack-band width h develops (see Fig. 2B).

Having passed the peak load the crack band localizes. The crack band width diminishes and the deformation within the crack band increases. The final failure occurs due to one single crack.

The total deformation of the specimen may be split up into the bulk deformation and the deformation of the crack band. The deformation of the crack band may be described either as an additional strain of a crack band with a fixed length h^* or as the crack width of a single crack. In the case of a single crack the crack band width diminishes to zero.



For most applications the crack band model and the single crack model are equivalent, but occasionally, the assumption concerning the crack band width (equals zero or greater zero and constant) may influence the result of a calculation. To create new crack surfaces the crack propagation criteria must be fulfilled over the crack band width. A crack starts propagating if the stress is equal to the tensile strength: either at one point (single crack) or over the crack band width (crack band).

In the case of, for instance, a three point bending test this leads to a dependency of the crack load from the crack band width (See Fig. 3).

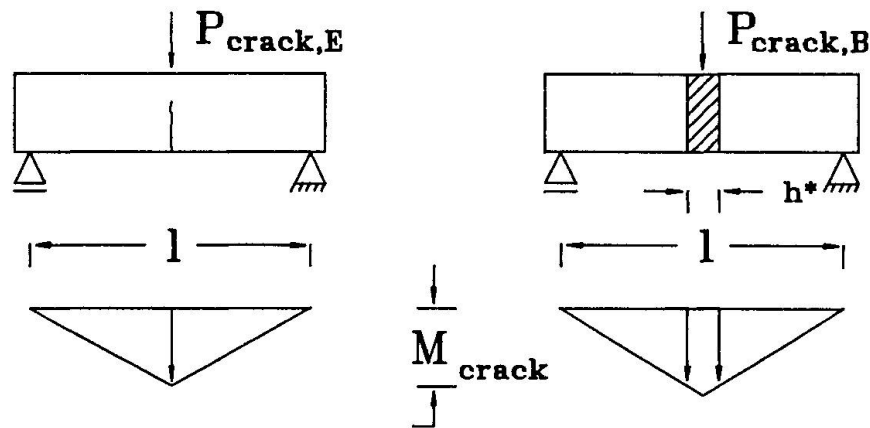

Fig. 3: Crack load of a three point bending test

As mentioned the micro crack accumulation starts within a crack band. The width of this crack band diminishes with increasing deformation. This leads at last to one single crack. The crack band width is not constant.

In this sense any assumption of a constant crack band width – equal or unequal zero – is arbitrary.

Hillerborg introduced the fictitious crack model, where he collected the deformation of the crack band to the crack-width w of one single 'fictitious' crack. The relation between the crack width of the 'fictitious' crack and the stress is the σ - w -relation. Two mechanisms contribute to the stress transfer over the crack. At the beginning of cracking it is merely a 'fictitious' crack. The crack width is the collected deformation of a band of micro-cracks. Within this crack band material bridges transfer the load. After the formation of a real single crack the stress transfer is possible due to aggregate interlock. In most cases a crack will run along the interfaces between the aggregate grains and the cement paste. The grains are pulled out of the paste. Due to this, friction forces between grains and matrix occur. The grains act like friction blocks and transfer friction forces over the crack.

Many experimental results are available for the σ - w -relation in the case of monotonic loading. Fig. 4 shows some suggestions taken from [1,2,3,4,5]. With the exception of the linear model, which is often chosen because of its simplicity, all σ - w -relations show the same behavior. The first branch of the relation is very steep, whereas the second branch is more flat. Most practical applications are insensitive to the exact shape of the σ - w -relation. It makes no difference which of these suggestions is chosen.

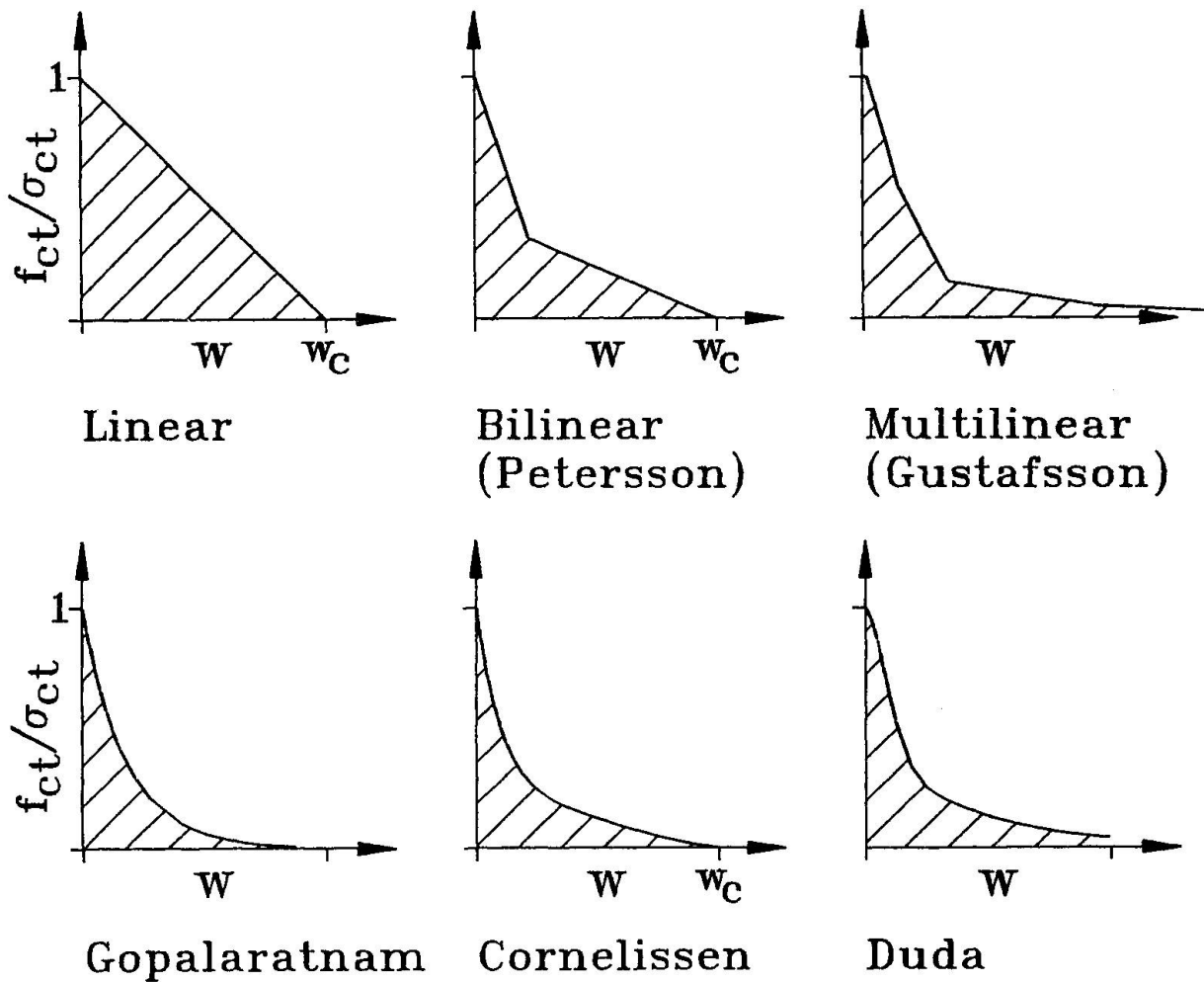

Fig. 4: σ - w -relations

Contrary to the monotonic loading, only few models are available for the case of cyclic loading. Figure 5 shows the models of Rots [6], Gylltoft [7], Reinhardt [8] and Duda [5]. The first three models use polygonal courses for the description of the hysteresis loop and an additional model for the envelope curve. The model of Duda is a rheological material model and describes both the envelope curve and the hysteresis loops.



The bulk behavior is described by a σ - ϵ -relation (see Figure 2). This relation is linear almost up to the peak load. The modulus of elasticity is equal to the initial tangential modulus of elasticity of the pressure part of the material behavior. The Poisson's ratio is in the order of $\mu = 0.15 \dots 0.25$. Just before the peak load is reached, the σ - ϵ -relation bends of from the linear behavior. For the state of loading where the nonlinearity starts very different experimental results are available. In some experiments the nonlinearity starts at about half of the peak load, in other experiments the curve is linear up to the peak load. These differences in the experimental results are caused by the different boundary conditions. Any kind of unsystematic loading, like internal bending due to non-uniform cracking, residual stresses due to differential shrinkage, notch effects, etc. causes nonlinearities. Theoretical considerations [5] show that even when the material behaves linear-elastic up to the tensile strength, a specimen may behave non-linear before the peak load is reached (see Fig. 10). The nonlinear behavior of test specimens is more a specimen behavior than a material behavior. Because of this, it seems to be fair to assume linear elastic bulk material behavior up to the tensile strength, for the loading and unloading path.

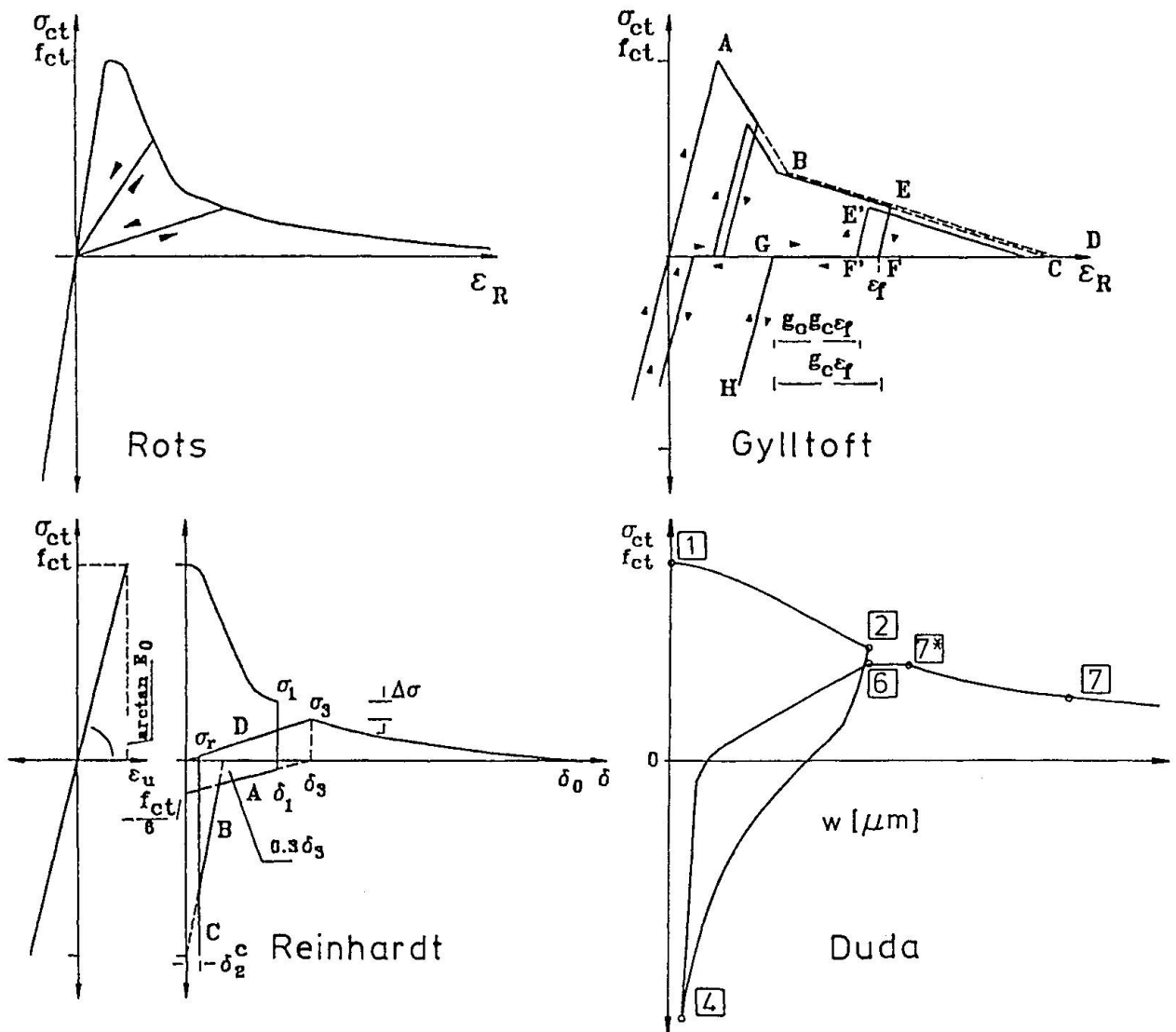

Fig. 5: Material models for cyclic loading

3. MAIN PARAMETER INFLUENCING STRAIN-SOFTENING

The strain-softening behavior of tensile loaded concrete can be described with the σ - w -relation. The parameters of the σ - w -relation are:

- tensile strength f_{ct}
- fracture energy G_F
- the shape of the curve

The tensile strength is a generally accepted material parameter of concrete. There are standard tests (axial tensile test, bending test, brazilian test) for the determination of f_{ct} . The tensile strength of concrete is influenced by the same parameters as the compressive strength. These parameters are water/cement ratio, strength of cement, the strength and the kind of aggregate. The tensile strength can be approximated from the compressive strength e.g. Rüsç [9]:

$$f_{ct} = c \cdot \sqrt[3]{f_c^2}$$

The factor c is an empirical constant. For the 5% fractil $c = 0.17$, for the mean $c = 0.24$ and for the 95% fractil $c = 0.32$ is valid.

The fracture energy is the energy needed for the creation and complete opening of one unit new crack surface. It is equal to the area under the σ - w -relation (hatched areas in Fig. 4). This leads to

$$G_F = \int_0^{w_c} \sigma_{ct}(w) \cdot dw$$

The upper limit of integration w_c is equal to the crack width in which the crack is stress free. For models without such an ultimate crack width the upper limit is infinity. The fracture energy depends on:

- aggregate
 - * grading curve
 - * maximum aggregate size
 - * aggregate surface (rough or smooth)
 - * aggregate strength
- concrete strength
- water/cement ratio
- age
- curing
- temperature
- loading rate
- workability, consistence



One of the most important influencing factors is the percentage of coarse aggregate grains. The coarse grains are the bridges between the crack interfaces. Therefore, G_F increases both with the percentage of coarse grains and with the maximum grain size (d_{max}). In Figure 6 experimental results from Mihashi [10], Petersson [1], Wolinski [11], Kleinschrodt [12] Roelfsta [13], Wittmann [14], Carpinteri [15] and Duda [5] and a theoretical model introduced in Duda [5] are shown. The increase of G_F (y - axes) with the maximum grain size (x - axes) is obvious. There is a big scatter in the results of the different sources. The fracture energy depends not only on d_{max} but also on the other parameters as mentioned above.

These other parameters are different for different sources, what explains the big scatter.

Furthermore it is impossible to change only one parameter (e.g. d_{max}) without changing also at least one of the others.

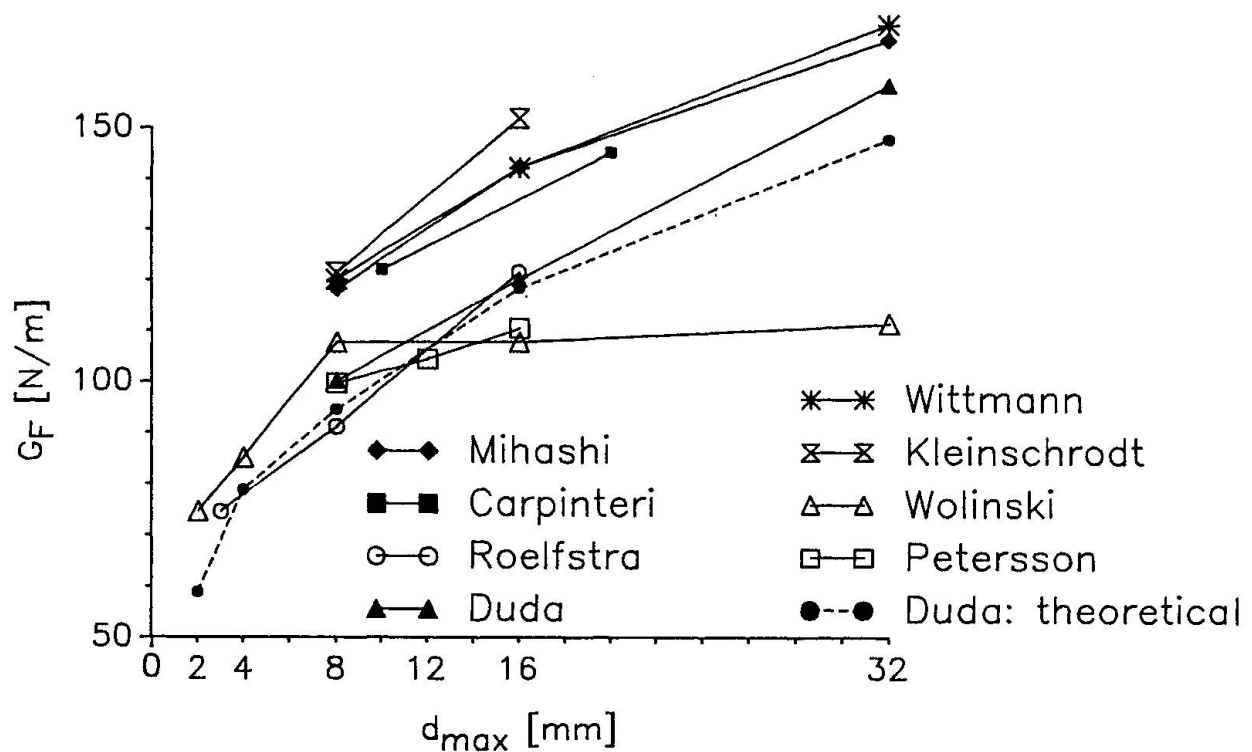

Fig. 6: Fracture energy over maximum aggregate size

Crushed aggregate with rough surfaces causes an increase in G_F compared with water-worn gravel with a smooth surface. The relation between the strength of the aggregate and the cement paste influences also the shape of the $\sigma-w$ -relation. Figure 7 shows typical $\sigma-w$ -relations of normal-, high strength- and light weight-concrete. In the case of comparatively weak cement paste and strong aggregate grains the crack runs through the paste and at the interfaces between the grains and the paste. The grains are pulled out of the cement matrix, transferring friction forces over the crack. When the cement paste reaches the strength of the aggregates, either due to the increased strength of the cement paste in the case of high strength concrete or due to the relative weak aggregates in the case of light-weight concrete, the crack will split most of the grains. The stress transferring capacity for greater crack width decreases rapidly. Due to this high-strength and light-weight concrete behaves much more brittle than normal concrete.

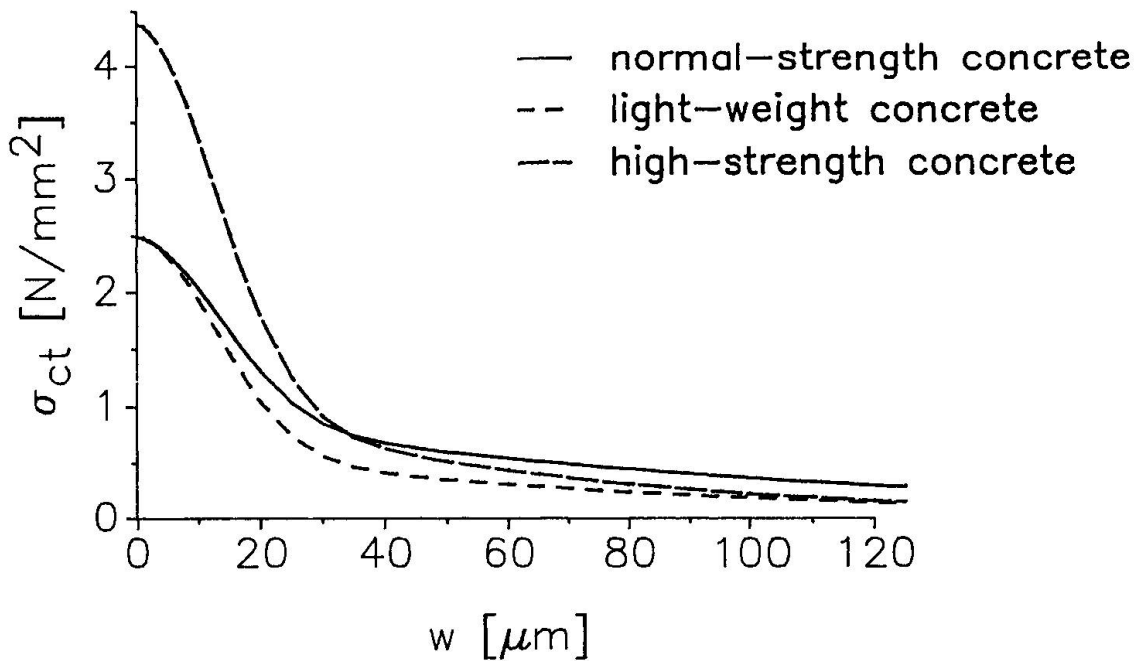

Fig. 7: σ - w -relation of normal-, lightweight- and high strength-concrete

The water/cement ratio influences G_F similar to its effect on the strength (See also Hordijk [17]). The maximum will be reached with $W/C = 0.4$. Higher and lower values lead to a decrease in G_F .

4. CRITICAL REVIEW OF TEST SETUPS

Various test setups are used to study the material properties of tensile loaded concrete. Some of these will be introduced and discussed.

4.1 Notched and un-notched centric tension test

It is self-evident to study the tension behavior of concrete with centric tension tests. A test setup may be as shown in Figure 8 at the left side. Loading plates are glued to both ends of the specimen. A test including also the descending path of the load deflection curve is feasible under deformation-control only. In the case of a cylinder (length = 300 mm) made of normal concrete the outcome of this test will be approximate as plotted on the right side in figure 8. The total deformation (Δl) is the sum of the bulk deformation ($\epsilon \cdot l$) and the crack width (w). Due to the elastic unloading of the bulk there will be a snap-back in the load-deformation curve. As the test is controlled by increasing the total deformation, it is impossible to control the test between point A and B. Due to the elastic unloading of the testing machine, the test fails between the points A and \tilde{B} in an unstable manner. As the distance between point A and \tilde{B} represents about two third of the peak load, it is not reasonable to study the post peak response of concrete with such a kind of test.



To avoid the unstable failure the test must be controlled by a deformation which does not exhibit any snap-back. This is possible by using notched specimens. The crack-mouth-opening displacement of the notch can be used to control the test. From the theoretical point of view it is easy to run such a test, but in reality, there are still problems with the stability of the test and with the non-uniform crack opening.

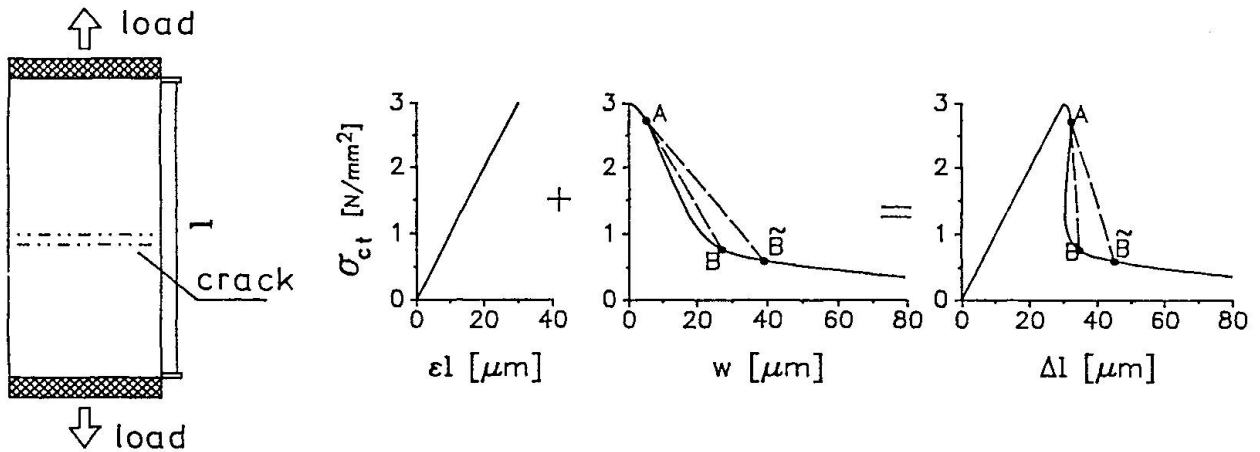

Fig. 8: Test setup for centric tension test

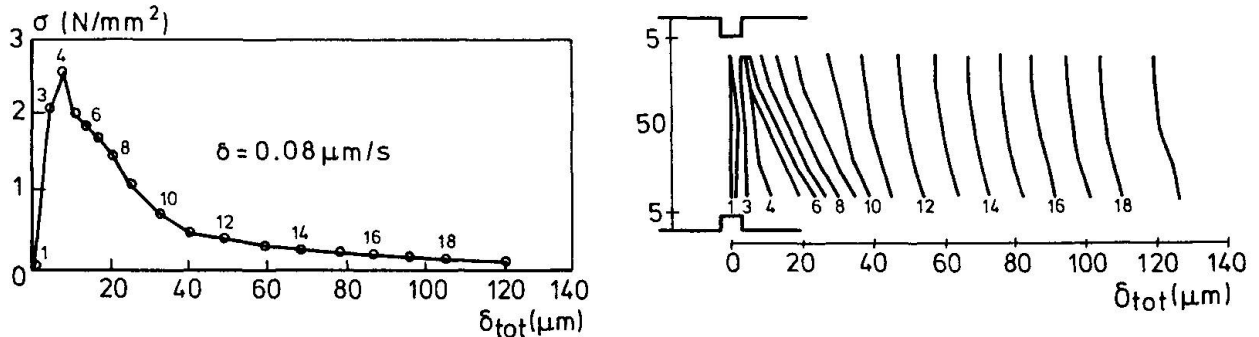

Fig. 9: Centric tension test

Figure 9 shows the results of a centric tension test with a notched specimen (Cornelissen [4]): on the left side the average stress over the average deformation of the crack-band, at the right side the crack profile for different load steps. The crack opening is non uniform. As the stress depends on the crack width the stress distribution is also non-uniform. Consideration of only the average stress and the average deformation is a pure approximation for the real σ - w -relation. Figure 10 shows the average σ - w -relation and the recalculated 'real' σ - w -relation of this test. The difference in the tensile strength is about 12%.

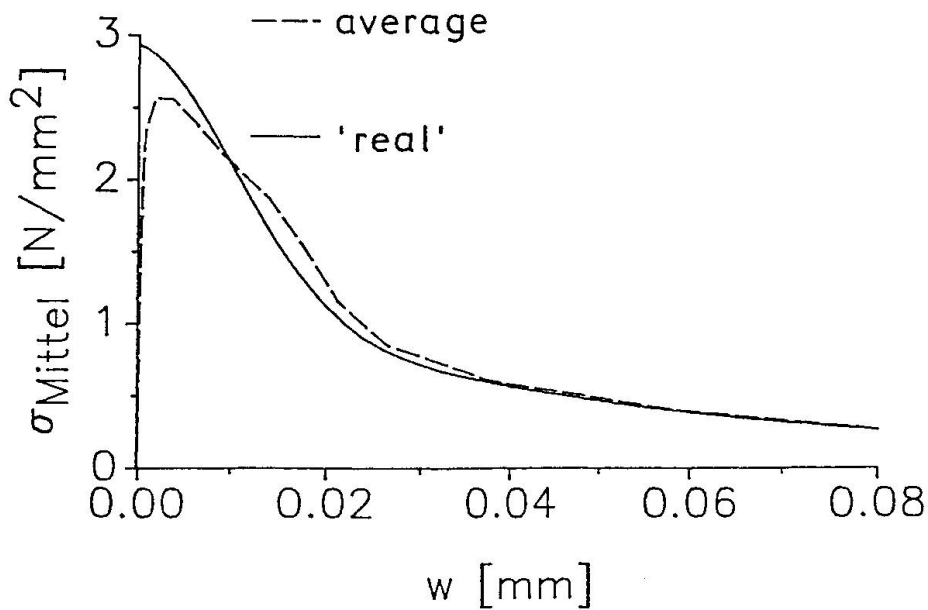

Fig. 10: Average and 'real' σ - w -relation

4.2 The brazilian test (splitting test).

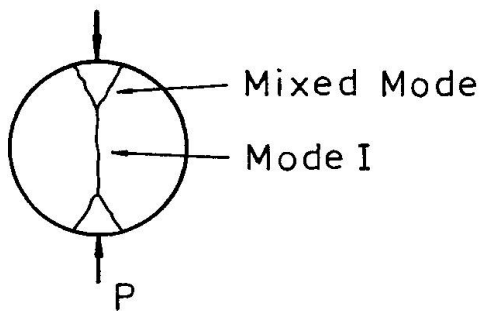

Fig. 11: Brazilian test

The splitting test is widely used to determine the tensile strength of concrete. A concrete cylinder or prism is loaded between two edges. The specimen fails due to a tension crack parallel with the load direction (see Figure 11). It is a reasonable test for the determination of the tensile strength, but there is no way of getting a reasonable post peak response with this test. At peak load wedge-shaped concrete pieces develop next to the edges. The post peak response is governed by the mixed mode (tension and shear) behavior at the interface between the wedges and the bulk.

Mode I (tension) occurs only in the center of the specimen. It seems to be impossible to extract the mode I material behavior from of the complicated mixed mode behavior of a brazilian test.

4.3 Three and four point bending tests

Bending tests are much easier to perform than centric tension tests. There is no need to glue load plates at the specimen. Because of the redistribution of stress, the descending part of the load deformation curve is less steep than in the case of pure tension.

Most bending tests are performed with notched beams because the place of cracking is fixed by the notch. Depending on the geometry and the material properties, the snap-back problems already mentioned may also occur with bending tests. Four point bending tests are advantageous as there is no shear-force between the loading points. With three point bending



tests there is always a shear force acting between the crack-interfaces (See Fig. 12). This may disturb the test-results.

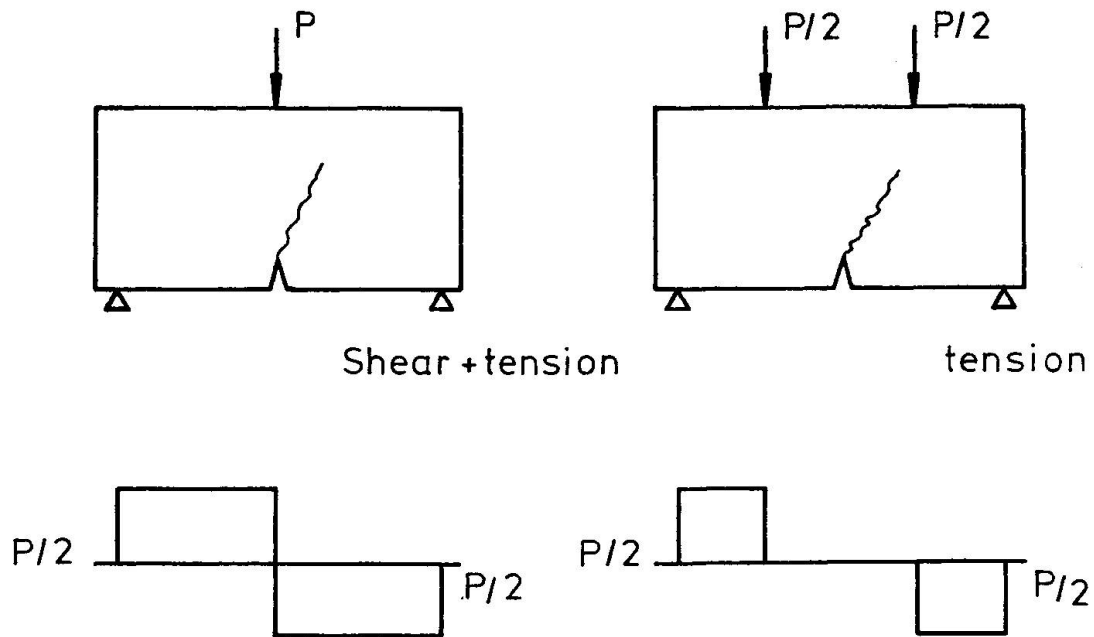

Fig. 12: Shear forces in three and four point bending

In order to extract the material behavior from the specimen behavior a recalculation is necessary. Depending on the available soft- and hardware equipment this recalculation procedure may be considerable time consuming.

4.4 Compact tension testes

Two different types of compact tension tests are shown in Figure 13. The compact tension specimens have the same fracture surface as other specimens, however, they are smaller in dimension. This may be advantageous for casting and handling the specimen. The crack interface is under pure tension. A recalculation equivalent to the recalculation of bending tests is necessary.

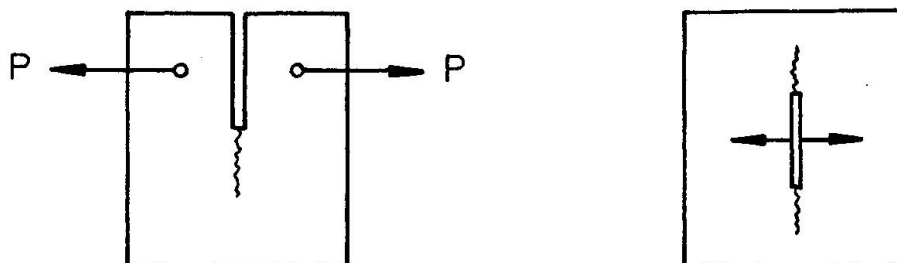

Fig. 13: Compact tension test

4.5 Conclusions

A lot of different test setups are in use. Depending on the aim of the test, the available test machine, the hard- and software equipment, etc. any of these may be advantageous or disadvantageous.

5. SCALE EFFECTS

When geometrical similar specimens do not behave similar for different sizes, we are dealing with a scale or size effect. Size effects occur anywhere in concrete. They are most significant in the case of tensile or shear load and less significant in the case of compression. A very well-known size effect is the dependence of the flexural strength of plain concrete on the depth of the beam. The increase in flexural strength is caused by the strain-softening behavior of concrete. The dependence of the flexural strength on the depth, the eccentricity, and the σ - w -relation was analyzed using finite elements. The depth was varied between 5 cm and 2 m, the eccentricity between zero (tension) and infinity (bending). The four different σ - w -relations plotted in Figure 14 where assumed.

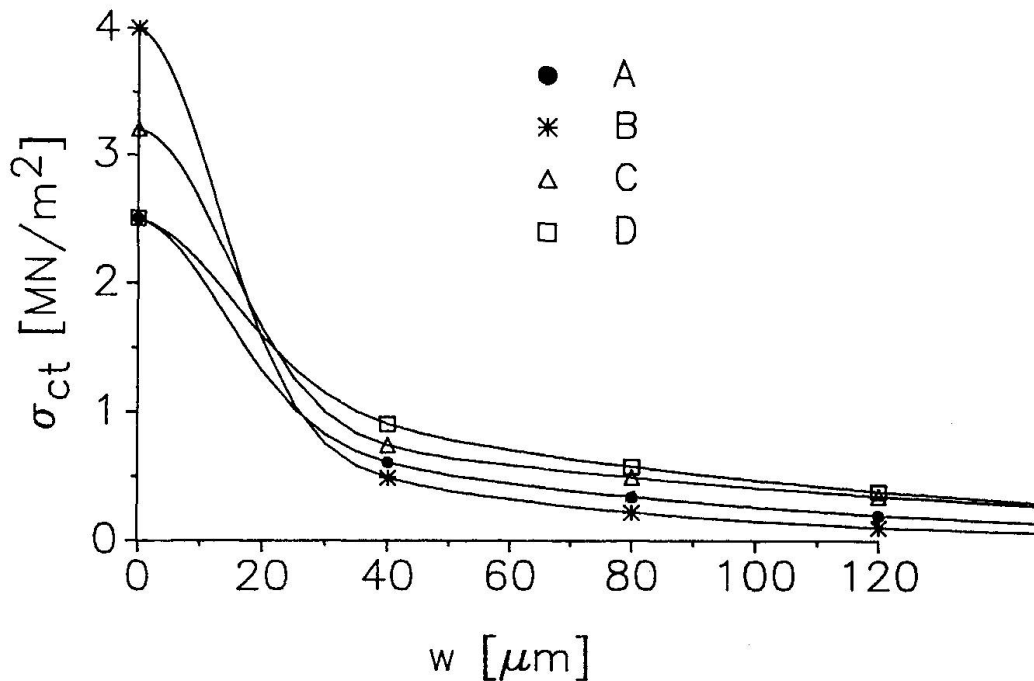

Fig. 14: σ - w -relations

Type A: normal concrete, C25,
gravel, $d_{max} = 8$ mm
Type C: normal concrete, C35,
gravel, $d_{max} = 32$ mm

Type B: high strength concrete, C80,
crushed limestone, $d_{max} = 8$ mm
Type D: normal concrete, C25
crushed basalt, $d_{max} = 16$ mm



The flexural strength f_{cf} is defined as the ratio between the ultimate bending moment M_u and the moment of resistance.

$$f_{cf} = \frac{M_u \cdot 6}{b \cdot d^2}$$

The ratio of flexural strength f_{cf} and tensile strength f_{ct} is plotted in Figure 15 over the depth of the beam. It is obvious that the increase in flexural strength depends on the depth and on the kind of σ - w -relation.

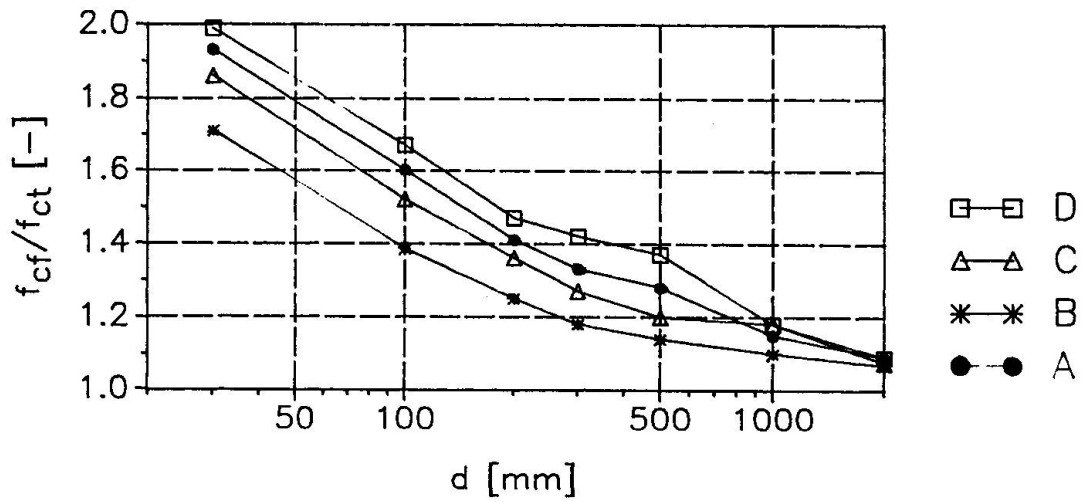

Fig. 15: Relative flexural strength of concrete under pure bending

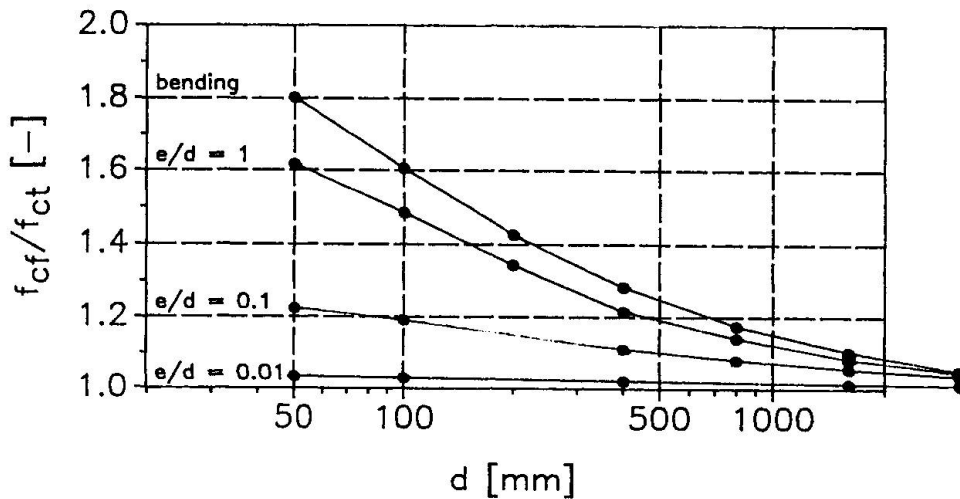

Fig. 16: Relative flexural strength of concrete under bending and normal force

A normal force action simultaneously with a bending moment influences the increase in flexural strength. In Figure 16 the relative flexural strength is plotted over the depth for different relative eccentricities e/d . The flexural strength for normal force N_u and bending moment $M_u = e \cdot N_u$ is defined as:

$$f_{cf} = \frac{N_u}{b \cdot d} \left(\frac{e \cdot 6}{d} + 1 \right)$$

The increase in flexural strength occurs due to the redistribution of the tensile stress. The stress distribution under ultimate bending moment is plotted in Figure 17 for depth $d = 10\text{cm}$, $d = 40\text{cm}$ and $d \rightarrow \infty$.

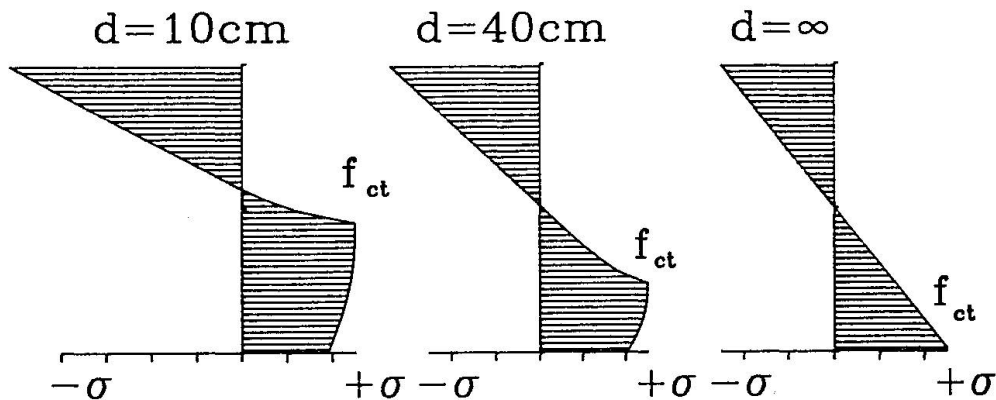

Fig. 17: Stress distribution for different beam depth

The extension of the redistribution zone depends on the σ - w -relation. The relative size of this zone is small for big beam depth and for small eccentricities.

The increase in flexural strength depends not only on the depth but to the same extend on the eccentricity and on the material properties. Even in this very simple case it is impossible to describe the size effect by a simple equation depending only on a geometrical parameter e.g. the depth of the beam. Generalized for other cases it must be concluded that any equation describing the size effect only with a geometrical parameter is a pure approximation of the real behavior.

6. BASIC CONCEPT FOR USING CONCRETE TENSILE STRENGTH

Whether the concrete tensile strength can be used or not depends essentially on the post peak response of the structural member. It must be distinguished between a pre-announced and an abrupt failure without any warning. In most cases the pre-announcements are visible cracking or unusually increasing deformations. In the first case one can hardly trust in the concrete tensile strength. In the second case the tensile strength may be used.

To decide whether there will be a gradual or sudden drop in bearing capacity the deformation behavior of concrete has to be calculated. In the case of pure tension this can be done using the material models as described in this paper.



There are some cases where the tensile strength of concrete is already used. It is known from experience that we can trust in the tensile strength, for instance in the case of very thin slabs or anchorage of reinforcement bars. The analysis of these cases shows that the redistribution zone is large compared to the total loaded area.

Large stress redistribution capacity leads to a large deformation before and after the peak load is reached. In this case tensile strength of concrete may be used. The redistribution zone may be large due to the geometry and/or due to the material behavior.

In cases where the redistribution zone is large due to the geometry, the tensile strength is often unwittingly made use of. Here, the advanced material models may be used for better understanding.

The other application - and perhaps the most interesting one - is whether or not one can predict a small or large redistribution zone in a given situation and whether or not one can rely on the tensile strength in said situation.

There is a very steep decay in the first branch of the σ - w -relation. In many cases this also leads to a steep decay in the load deformation curves of structural members made of plain concrete.

With the knowledge of the reason of sudden or gradual failure new advanced concrete mixtures can be found which exhibit a less steep decay in the bearing capacity after the first cracking (e.g. the admixture of fibers).

7. CONCLUSIONS

To describe the behavior of tension loaded members both the tensile strength and the deformation capacity is needed. In most cases it is much more important how the concrete behaves after cracking than to know the stress at which the first crack occurs. A concrete should not be judged by his strength only. The ductility represented by the fracture energy is as important as the strength, in some cases even more important.

References

- [1] Petersson P.-E.: Crack growth and development of fracture zones in plain concrete and similar Materials. Report TVBM-1006, Thesis, Div. of Building Materials, Univ. of Lund Sweden, 1981.
- [2] Gustafsson, P.J.: Fracture Mechanics Studies of nonyielding materials like concrete. Report TVBM-1007, Thesis, Div. of Building Materials, Univ. of Lund Sweden, 1985.
- [3] Gopalaratnam, V.S.; Shah, S.P.: Softening response of plain concrete in direct tension. ACI Journal, 82-27, pp. 310-323, 1985.

- [4] Cornelissen, H.A.W.; Hordijk, D.A.; Reinhardt, H.W.: Experiments and theory for the application of fracture mechanics to normal and lightweight concrete. Contributions international conference on fracture mechanics of concrete, Lausanne, 1-3 October, 1985.
- [5] Duda, H.: Bruchmechanisches Verhalten von Beton unter monotoner und zyklischer Zugbeanspruchung. Thesis, Institut für Massivbau, TH Darmstadt, 1990.
- [6] Rots, J.G.; Nauta, P.; Kusteres, G.M.A.; Blaauwendraad, J.: Smeared crack approach and fracture localization in concrete. *Heron* 30(1), Delft, 1985.
- [7] Gylltoft, K.: Fracture mechanics model for fatigue in concrete. *RILEM Materials and Structures*, 17(97), pp. 55-58, 1984.
- [8] Reinhardt, H.W.; Cornelissen, H.A.W.; Hordijk, D.A.: Tensile test and failure analysis of concrete. *Journal of Structural Engineering*, 112(11), 1986.
- [9] Rüsç, H.: Die Ableitung der charakteristischen Werte der Betonzugfestigkeit. *Beton* (2), pp.55-58, 1975.
- [10] Mihashi, H.; Wittmann, F.H.; Simonin, P.; Rokugo, K.: Fracture energy evaluation of concrete with compact tension testes. Proc. 9th Ann. Meeting of Japan Concrete Institut, Vol. 9-2, pp. 657-662, 1987.
- [11] Wolinski, S.; Hordijk, D.A.; Reinhardt, H.W.; Cornelissen, H.A.W.: Influence of aggregate size of fracture mechanics parameter of concrete. *Int. J. Cement Composites and Lightweight Concrete*, 9(2), pp. 95-103, 1987.
- [12] Kleinschrodt, H.D.; Winkler, H.: The influence of the maximum aggregate size and the size of specimen on fracture mechanics parameter. *Fracture Toughness and Fracture Energy*, F.H. Wittmann (editor), pp. 137-148, Elsevier, 1986.
- [13] Roelfsta, P.E.; Wittmann, F.H.: Numerical method to link strain softening with failure of concrete. *Fracture Toughness and Fracture Energy*, F.H. Wittmann (editor), pp.163-175, Elsevier, 1986.
- [14] Wittmann, F.H.; Rokugo, K.; Bruhwiler, E. Mihashi, H.; Simonin, P.: Fracture energy and strain softening of concrete as determined by means of compact tension specimens. *Materials and Structures*, (21), pp. 21-32, 1987.
- [15] Carpinteri, A.; Gerrara, G.; Melchiorri, G.: Single edge notched specimen subjected to four point shear. *Fracture of Concrete and Rock*, S.P. Shah and S.E. Swartz (editor), pp. 605-614, Elsevier, 1989.
- [16] Getto, R.; Bažant, Z.P.; Karr, M.E.: Fracture Properties and Brittleness of High Strength Concrete. Report No.89-10/B627f, Center for Advanced Cement-Based Materials, Northwestern University, Evanston, 1989
- [17] Hordijk, D.A.; Van Mier, J.G.M.; Reinhardt, H.W.: Material Properties. *RILEM Report, Fracture Mechanics of Concrete*, L. Elfgren (editor), pp. 67-127 Chapman and Hall, 1989.

Leere Seite
Blank page
Page vide